

CombiFlex

Vertical centrifugal pump

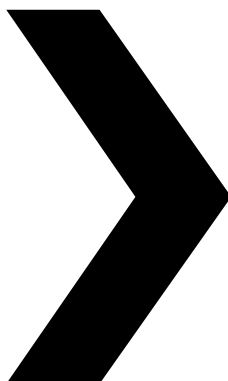

REVISION: CF/EN (2301) 6.7

EC Declaration of Conformity

(Directive 2006/42/EC, appendix II-A)

Manufacturer

SPX Flow Technology Assen B.V.
Dr. A.F. Philipsweg 51
9403 AD Assen
The Netherlands

hereby declares that all pumps member of product-families, CombiFlex(U)(B), CombiPrime H, CombiMag, CombiMagBloc, CombiPro(L)(M)(V), CombiPrime V, CombiSump, CombiTherm, CombiWell, FRE, FRES, FREF, FREM, KGE(L), KGEF, MCH(W)(S), MCHZ(W)(S), MCV(S) whether delivered without drive, or delivered as an assembly with drive, are in conformity with the provisions of Directive 2006/42/EC (as altered most recently) and where applicable the following directives and standards:

- EC directive 2014/35/EU, "Electric equipment for use within certain voltage limits"
- EC directive 2014/30/EU, "ElectroMagnetic Compatibility"
- standards EN-ISO 12100, EN 809
- standard EN 60204-1 if applicable

The pumps to which this declaration refers may only be put into operation after they have been installed in the way prescribed by the manufacturer, and, as the case may be, after the complete system of which these pumps form part, has been made to fulfil all applicable essential Health & Safety requirements.

EC Declaration of Incorporation

(Directive 2006/42/EC, appendix II-B)

Manufacturer

SPX Flow Technology Assen B.V.
Dr. A.F. Philipsweg 51
9403 AD Assen
The Netherlands

hereby declares that the partly completed pump (Back-Pull-Out unit), member of product-families CombiFlex(U)(B), CombiPrime H, CombiMag, CombiMagBloc, CombiTherm, CombiPro(L)(M)(V), CombiPrime V, FRE, FRES, FREF, FREM, KGE(L), KGEF is in conformity with the provisions of Directive 2006/42/EC as well as with the following standards:

- EN-ISO 12100, EN 809

and that this partly completed pump is meant to be incorporated into the specified pump unit and may only be put into use after the complete machine of which the pump under consideration forms part has been made and declared to comply with all Directives.

These declarations are issued under the sole responsibility of the manufacturer
Assen, January 1st 2023

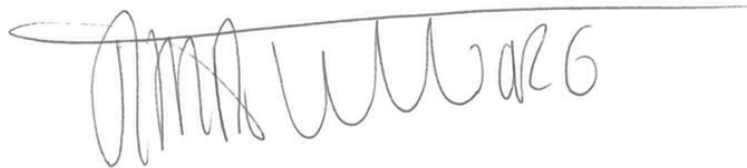

R. van Tilborg,
Managing Director

Instruction manual

All technical and technological information in this manual as well as possible drawings made available by us remain our property and shall not be used (otherwise than for the operation of this pump), copied, duplicated, made available to or brought to the notice of third parties without our prior written consent.

SPX FLOW is a global multi-industry manufacturing leader. The company's highly-specialized, engineered products and innovative technologies are helping to meet rising global demand for electricity and processed foods and beverages, particularly in emerging markets.

SPX Flow Technology Assen B.V.
Dr. A. F. Philipsweg 51
9403 AD Assen
The Netherlands
Tel. +31 (0)592 376767
Fax. +31 (0)592 376760

Copyright © 2022 SPX FLOW, Inc

Table of Contents

| | | |
|----------|--|-----------|
| 1 | Introduction | 9 |
| 1.1 | Preface | 9 |
| 1.2 | Safety | 9 |
| 1.3 | Guarantee | 10 |
| 1.4 | Inspection of delivered items | 10 |
| 1.5 | Instructions for transport and storage | 10 |
| 1.5.1 | Weight | 10 |
| 1.5.2 | Use of pallets | 10 |
| 1.5.3 | Hoisting | 11 |
| 1.5.4 | Storage | 12 |
| 1.6 | Ordering parts | 12 |
| 2 | General | 13 |
| 2.1 | Pump description | 13 |
| 2.2 | Type code | 13 |
| 2.3 | Serial number | 14 |
| 2.4 | Applications | 14 |
| 2.5 | Construction | 14 |
| 2.5.1 | Bearing groups | 14 |
| 2.5.2 | Pump casing/impeller/suction bend | 15 |
| 2.5.3 | Shaft sealing | 15 |
| 2.5.4 | Bearing | 15 |
| 2.5.5 | Lantern CombiFlex Spacer (K1, K3) | 15 |
| 2.5.6 | Lantern CombiFlex Short (K2, K4) | 15 |
| 2.5.7 | Foot pads | 16 |
| 2.6 | Application area | 16 |
| 2.7 | Re-use | 16 |
| 2.8 | Scrapping | 16 |
| 3 | Installation | 17 |
| 3.1 | Safety | 17 |
| 3.2 | Preservation | 17 |
| 3.3 | Environment | 17 |
| 3.4 | Mounting | 18 |
| 3.4.1 | Assembling a pump unit | 18 |
| 3.4.2 | Installation of a pump unit | 18 |
| 3.4.3 | Alignment of the coupling | 19 |
| 3.4.4 | Tolerances for aligning the coupling | 19 |
| 3.5 | Piping | 21 |
| 3.6 | Accessories | 21 |

| | | |
|----------|---|-----------|
| 3.7 | Connection of the electric motor | 21 |
| 4 | Commissioning | 23 |
| 4.1 | Inspection of the pump | 23 |
| 4.2 | Inspection of the motor | 23 |
| 4.3 | Preparing the pump unit for commissioning | 23 |
| 4.4 | Checking the sense of rotation | 23 |
| 4.5 | Start-up | 23 |
| 4.6 | Pump in operation | 24 |
| 4.7 | Noise | 24 |
| 5 | Maintenance | 25 |
| 5.1 | Daily maintenance | 25 |
| 5.2 | Mechanical seal | 25 |
| 5.3 | Lubrication of the bearings | 25 |
| 5.4 | Environmental influences | 25 |
| 5.5 | Noise | 25 |
| 5.6 | Motor | 26 |
| 5.7 | Faults | 26 |
| 6 | Problem solving | 27 |
| 7 | Disassembly and assembly | 29 |
| 7.1 | Precautionary measures | 29 |
| 7.2 | Special tools | 29 |
| 7.3 | Designation of parts | 29 |
| 7.3.1 | Position numbers | 29 |
| 7.3.2 | Constructive variants | 29 |
| 7.3.3 | Draining | 30 |
| 7.4 | Disassembly and assembly Top Pull Out unit | 30 |
| 7.4.1 | Disassembly Top Pull Out unit, version K1 | 30 |
| 7.4.2 | Assembly Top Pull Out unit, version K1 | 30 |
| 7.4.3 | Disassembly Top Pull Out unit, version K2 | 31 |
| 7.4.4 | Assembly Top Pull Out unit, version K2 | 31 |
| 7.4.5 | Disassembly Top Pull Out unit, versions K3 and K4 | 31 |
| 7.4.6 | Assembly Top Pull Out unit, versions K3 and K4 | 32 |
| 7.5 | Replacement the impeller and the wear ring | 33 |
| 7.5.1 | Disassembly of the impeller | 33 |
| 7.5.2 | Mounting the impeller | 33 |
| 7.5.3 | Disassembling the wear ring | 34 |
| 7.5.4 | Assembling the wear ring | 34 |
| 7.6 | Mechanical seal | 35 |
| 7.6.1 | Instructions for mounting a mechanical seal | 35 |
| 7.6.2 | Disassembly of the mechanical seal | 36 |
| 7.6.3 | Assembly of the mechanical seal | 36 |
| 7.7 | Bearing | 37 |
| 7.7.1 | Instructions for assembly and disassembly of bearings | 37 |
| 7.7.2 | Disassembly of bearings, bearing brackets 1, 2 and 3 | 38 |
| 7.7.3 | Assembly of bearings, bearing brackets 1, 2 and 3 | 38 |
| 7.7.4 | Disassembly of bearings 200-400, 250-250, 250-315, 300-250, 300-315 | 39 |
| 7.7.5 | Assembly of bearings 200-400, 250-250, 250-315, 300-250, 300-315 | 40 |
| 7.7.6 | Disassembly of bearings 150B-400, 150-500, 200-250, 200-315 | 41 |
| 7.7.7 | Assembly of bearings 150B-400, 150-500, 200-250, 200-315 | 42 |
| 7.7.8 | Disassembly of bearings 125-500 | 43 |
| 7.7.9 | Assembly of bearings 125-500 | 44 |

| | | |
|-----------|---|-----------|
| 8 | Dimensions | 45 |
| 8.1 | Dimensions delivery flange | 45 |
| 8.1.1 | Dimensions delivery flange K1, K2 | 45 |
| 8.1.2 | Dimensions delivery flange K3, K4 | 46 |
| 8.2 | Dimensions suction flange | 46 |
| 8.2.1 | Dimensions suction flange K1, K2 | 46 |
| 8.2.2 | Dimensions suction flange K3, K4 | 46 |
| 8.3 | Dimensions foot pads K1, K2 | 47 |
| 8.4 | Dimensions foot pads 200-200 / 250B-315 K1, K2 | 47 |
| 8.5 | Pump dimensions K1 | 48 |
| 8.6 | Pump dimensions K2 | 50 |
| 8.7 | Pump dimensions K1, with suction bend | 52 |
| 8.8 | Pump dimensions 200-200 / 250B-315 K1, with suction bend | 54 |
| 8.9 | Pump dimensions K2, with suction bend | 55 |
| 8.10 | Pump dimensions 200-200 / 250B-315 K2, with suction bend | 57 |
| 8.11 | Pump dimensions K3, with suction bend | 58 |
| 8.12 | Pump dimensions K4, with suction bend | 60 |
| 9 | Parts | 63 |
| 9.1 | Ordering parts | 63 |
| 9.1.1 | Order form | 63 |
| 9.1.2 | Recommended spare parts | 63 |
| 9.2 | Pump construction K1 | 64 |
| 9.2.1 | Sectional drawing ..-160/..-200/..-250 | 64 |
| 9.2.2 | Parts list ..-160/..-200/..-250 | 65 |
| 9.2.3 | Sectional drawing ..-315/..-400 | 66 |
| 9.2.4 | Parts list ..-315/..-400 | 67 |
| 9.3 | Pump construction K2 | 69 |
| 9.3.1 | Sectional drawing | 69 |
| 9.3.2 | Parts list | 70 |
| 9.4 | Pump construction K3 | 71 |
| 9.4.1 | Sectional drawing 200-400, 250-250, 250-315, 300-250, 300-315 | 71 |
| 9.4.2 | Parts list 200-400, 250-250, 250-315, 300-250, 300-315 | 72 |
| 9.4.3 | Sectional drawing 150B-400, 150-500, 200-250, 200-315 | 74 |
| 9.4.4 | Parts list 150B-400, 150-500, 200-250, 200-315 | 75 |
| 9.4.5 | Sectional drawing 125-500 | 77 |
| 9.4.6 | Parts list 125-500 | 78 |
| 9.5 | Pump construction K4 | 80 |
| 9.5.1 | Sectional drawing 200-400, 250-250, 250-315, 300-250, 300-315 | 80 |
| 9.5.2 | Parts list 200-400, 250-250, 250-315, 300-250, 300-315 | 81 |
| 9.5.3 | Sectional drawing 150B-400, 150-500, 200-250, 200-315 | 83 |
| 9.5.4 | Parts list 150B-400, 150-500, 200-250, 200-315 | 84 |
| 9.5.5 | Sectional drawing 125-500 | 86 |
| 9.5.6 | Parts list 125-500 | 87 |
| 9.6 | Suction bend K1/K2 | 89 |
| 9.6.1 | Sectional drawing suction bend | 89 |
| 9.6.2 | Parts of suction bend | 89 |
| 9.6.3 | Sectional drawing suction bend 200-200 / 250B-315 | 90 |
| 9.6.4 | Parts of suction bend 200-200 / 250B-315 | 90 |
| 10 | Technical data | 91 |
| 10.1 | Grease | 91 |
| 10.2 | Quantity of grease for bracket group 4 bearings | 91 |
| 10.3 | Recommended locking liquids | 91 |
| 10.4 | Tightening moments | 92 |

| | | |
|--------|--|------------|
| 10.4.1 | Tightening moments for bolts and nuts | 92 |
| 10.4.2 | Tightening moments for cap nut | 92 |
| 10.5 | Maximum speed | 92 |
| 10.6 | Hydraulic performance | 94 |
| 10.7 | Noise data | 96 |
| 10.7.1 | Pump noise as a function of pump power | 96 |
| 10.7.2 | Noise level of entire pump unit | 97 |
| | Index | 99 |
| | Order form for spare parts | 101 |

1 Introduction

1.1 Preface

This manual is intended for technicians and maintenance staff and for those who are in charge of ordering spare parts.

This manual contains important and useful information for the proper operation and maintenance of this pump. It also contains important instructions to prevent potential accidents and damage, and to ensure safe and fault-free operation of this pump.



Read this manual carefully before commissioning the pump, familiarize yourself with the operation of the pump and strictly obey the instructions!

The data published here comply with the most recent information at the time of going to press. However they may be subject to later modifications.

SPXFLOW reserves the right to change the construction and design of the products at any time without being obliged to change earlier deliveries accordingly.

1.2 Safety

This manual contains instructions for working safely with the pump. Operators and maintenance staff must be familiar with these instructions.

Installation, operation and maintenance has to be done by qualified and well prepared personnel.

Below is a list of the symbols used for those instructions and their meaning:



Personal danger for the user. Strict and prompt observance of the corresponding instruction is imperative!



Risk of damage or poor operation of the pump. Follow the corresponding instruction to avoid this risk.



Useful instruction or tip for the user.

Items which require extra attention are shown in **bold print**.

This manual has been compiled by SPXFLOW with the utmost care. Nevertheless SPXFLOW cannot guarantee the completeness of this information and therefore assumes no liability for possible deficiencies in this manual. The buyer/user shall at all times be responsible for testing the information and for taking any additional and/or deviating safety measures. SPXFLOW reserves the right to change safety instructions.

1.3 Guarantee

SPXFLOW shall not be bound to any guarantee other than the guarantee accepted by SPXFLOW. In particular, SPXFLOW will not assume any liability for explicit and/or implicit guarantees such as but not limited to the marketability and/or suitability of the products supplied.

The guarantee will be cancelled immediately and legally if:

- Service and/or maintenance is not undertaken in strict accordance with the instructions.
- The pump is not installed and operated in accordance with the instructions.
- Necessary repairs are not undertaken by our personnel or are undertaken without our prior written permission.
- Modifications are made to the products supplied without our prior written permission.
- The spare parts used are not original SPXFLOW parts.
- Additives or lubricants used are other than those prescribed.
- The products supplied are not used in accordance with their nature and/or purpose.
- The products supplied have been used amateurishly, carelessly, improperly and/or negligently.
- The products supplied become defective due to external circumstances beyond our control.

All parts which are liable to wear are excluded from guarantee. Furthermore, all deliveries are subject to our "General conditions of delivery and payment", which will be forwarded to you free of charge on request.

1.4 Inspection of delivered items

Check the consignment immediately on arrival for damage and conformity with the advice note. In case of damage and/or missing parts, have a report drawn up by the carrier at once.

1.5 Instructions for transport and storage

1.5.1 Weight

A pump or a pump unit is generally too heavy to be moved by hand. Therefore, use the correct transport and lifting equipment. Weight of the pump or pump unit are shown on the label on the cover of this manual.

1.5.2 Use of pallets

Usually a pump or pump unit is shipped on a pallet. Leave it on the pallet as long as possible to avoid damages and to facilitate possible internal transport.



When using a forklift always set the forks as far apart as possible and lift the package with both forks to prevent it from toppling over! Avoid jolting the pump when moving it!

1.5.3 Hoisting

When hoisting a pump or complete pump units the straps must be fixed in accordance with figure 1 and figure 2.



When lifting a pump or a complete pump unit always use a proper and sound lifting device, approved to bear the total weight of the load!



Never go underneath a load that is being lifted!



If the electric motor is provided with a lifting eye, this lifting eye is intended only for the purpose of carrying out service activities to the electric motor! The lifting eye is designed to bear the weight of the electric motor only! It is NOT permitted to lift a complete pump unit at the lifting eye of an electric motor!

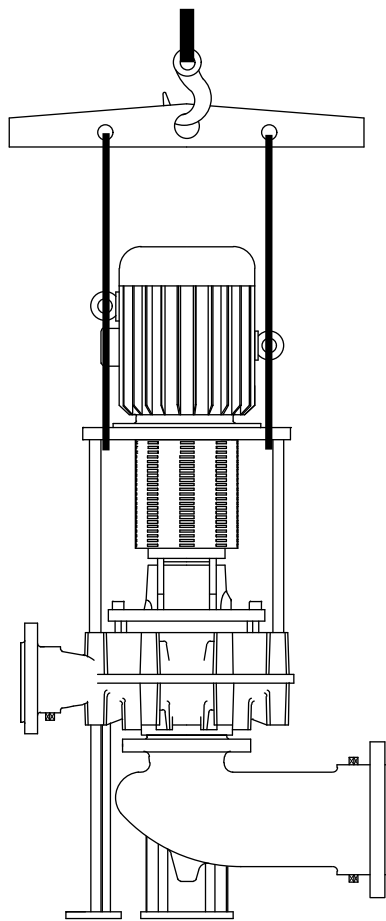

Figure 1: Lifting instructions for pump unit.

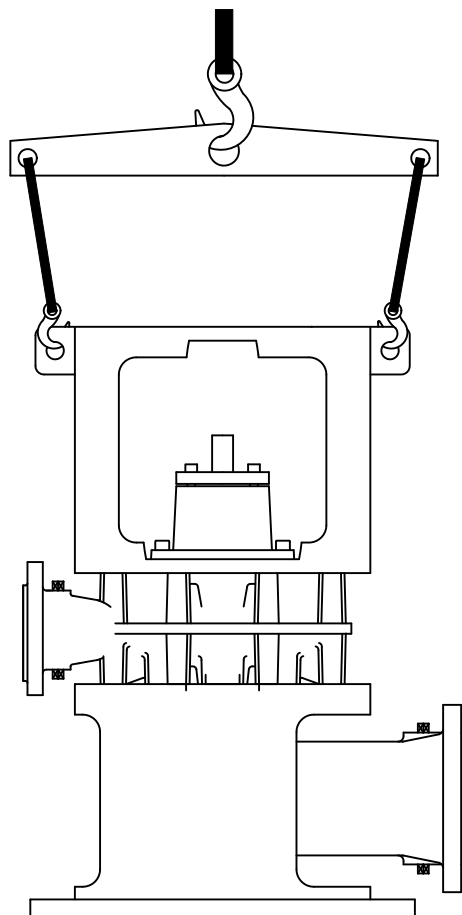

Figure 2: Lifting instructions pump unit of Bearing group 4.

1.5.4 Storage

If the pump is not to be used immediately the pump shaft must be turned by hand twice per week.

1.6 Ordering parts

This manual contains a survey of the spare parts recommended by SPXFLOW as well as the instructions for ordering them. A fax-order form is included in this manual.

You should always state all data stamped on the type plate when ordering parts and in any other correspondence regarding the pump.

➤ *This data is also printed on the label on the front of this manual.*

If you have any questions or require further information with regard to specific subjects, then do not hesitate to contact SPXFLOW.

2 General

2.1 Pump description

The CombiFlex is a range of vertical non-self-priming centrifugal pumps. The discharge and suction connection can be mounted in different positions in relation to each other. The pump is driven by a standard IEC vertical flange motor. The power is transmitted through a flexible coupling. Because of their modular lay-out, constructional components are widely interchangeable, also with other pump types of the Combi system.

2.2 Type code

Pumps are available in various designs. The main characteristics of the pump are shown in the type code.

Example: **CF 40-200 G1 K1**

| Pump family | |
|---------------------------------|---|
| CF | CombiFlex |
| Pump size | |
| 40-200 | diameter discharge connection [mm] - nominal impeller diameter [mm] |
| Pump casing/pump cover material | |
| G | cast iron |
| NG | nodular cast iron |
| B | bronze |
| Impeller material | |
| 1 | cast iron |
| 2 | bronze |
| 3 | aluminium bronze |
| Assembly | |
| K1 | flexible coupling with distance sleeve (spacer) |
| K2 | short version with flexible coupling |
| K3 | flexible coupling with distance sleeve (spacer) and welded lantern piece consisting of tube and flange elements |
| K4 | flexible coupling with welded lantern piece consisting of tube and flange elements |

2.3 Serial number

Serial number of the pump or pump unit are shown on the name plate off the pump and on the label on the cover of this manual.

Example: **19-001160**

| | |
|--------|---------------------|
| 19 | year of manufacture |
| 001160 | unique number |

2.4 Applications

- In general, this pump can be used for thin, clean or slightly polluted liquids. These liquids should not affect the pump materials.
- The maximum allowed system pressure and temperature and the maximum speed depend on the pump type and the pump construction. For relevant data see chapter 10 "Technical data".
- Further details about the application possibilities of your specific pump are mentioned in the order confirmation and/or in the data sheet enclosed with the delivery.
- Do not use the pump for purposes other than those for which it is delivered without prior consultation with your supplier.



Using a pump in a system or under system conditions (liquid, working pressure, temperature, etc.) for which it has not been designed may hazard the user!

2.5 Construction

2.5.1 Bearing groups

The pump range is divided in a number of bearing groups.

Table 1: Bearing group division.

| Bearing groups | | | |
|----------------|---------|----------|----------|
| 1 | 2 | 3 | 4 |
| 32-160 | 65-250 | 80-400 | 125-500 |
| 32-200 | 65-315 | 100-400 | 150B-400 |
| 40-160 | 80-200 | 125-315 | 150-500 |
| 40-200 | 80-250 | 125-400 | 200-250 |
| 40-250 | 80-315 | 150-315 | 200-315 |
| 50-160 | 100-200 | 150-400 | 200-400 |
| 50-200 | 100-250 | 250B-315 | 250-250 |
| 50-250 | 100-315 | | 250-315 |
| 65-160 | 125-250 | | 300-250 |
| 65-200 | 200-200 | | 300-315 |
| 80-160 | | | |

The main components are described below:

2.5.2 Pump casing/impeller/suction bend

These are the parts that get into contact with the pumped liquid. For each individual pump type there is only one construction of the pump casing and the impeller. The pump casing and the suction bend are available in cast iron and in bronze, the impeller in cast iron, bronze and aluminium bronze. The square suction bend has been designed in such a way that resistance is low and that all the same a low position of the pump in relation to the floor is possible.

2.5.3 Shaft sealing

The pump is provided with a mechanical shaft seal in accordance with EN 12756 (DIN 24960). The stationary part of the mechanical seal is mounted directly in the pump cover, whereas the rotating part is mounted on a bronze shaft sleeve so as to prevent contact between the pump shaft and the pumped liquid. A by-pass pipe from the discharge flange to the seal chamber provides the necessary flushing of the mechanical seal.

Pumps belonging to the same Bearing group have equal pump shaft diameters, with the same corresponding shaft sleeves, mechanical seals and bearings.

2.5.4 Bearing

Bearing groups 1, 2 and 3: The pump shaft is mounted directly in the pump cover by means of 2 grease lubricated angular contact bearings in "O" set-up.

Bearing group 4: The pump shaft is borne by a bearing bracket, mounted onto the pump cover. The grease lubricated bearing consists of 2 angular contact ball bearings in "X" set-up and a cylindrical roller bearing (or, depending on pump type, a ball bearing).

2.5.5 Lantern CombiFlex Spacer (K1, K3)

The lantern of the types ..-160,..-200 and.. -250 consists of rods (K1). The coupling is protected by a guard. For the types ..-315 and..-400 the lantern consists of profiled steel elements (K1). The openings between these elements are covered by perforated steel sheet.

Types 250, 315, 400 and 500 of bearing group 4 have a welded lantern piece (K3) with side-openings for the removal of the Top Pull Out unit. The side-openings are covered by perforated steel sheet.

Pump and motor are coupled by means of a flexible coupling with spacer sleeve ('spacer'). After the protection jacket and spacer have been removed, the rotating part of the pump can be easily dismantled as a whole without having to disconnect the electric motor or the piping. This construction is called the Top Pull Out-principle.

2.5.6 Lantern CombiFlex Short (K2, K4)

The lantern of the CombiFlex in version K2 consists of 4 or 8 rod-shaped legs. The coupling is protected by a guard.

Types 250, 315, 400 and 500 of bearing group 4 have a welded lantern piece (K4) with side-openings for the removal of the Top Pull Out unit. The side-openings are covered by perforated steel sheet.

Pump and motor are coupled by means of a flexible coupling. In this construction, a 'spacer' is lacking, so the K2 and K4 version is shorter. The Top Pull Out principle is not applicable here.

2.5.7 Foot pads

If the pump has been constructed with foot pads, the pads have to be fastened to the foundation. It is also possible to construct the pump without foot pads and suction bend. In that case, the pump casing is mounted on the foundation and immediately provided with a vertical suction pipe.

The foot rests of pump types of bearing brackets 1, 2 and 3 consist of profiled steel elements.

The foot rest of pump types 200-200, 250B-315 and of bearing bracket 4 consists of a cylindrical construction with side-openings for the passage of the suction bend.

2.6 Application area

The application area globally looks as follows:

Table 2: Application area.

| | Maximum value |
|-----------------|------------------------|
| Capacity | 1500 m ³ /h |
| Discharge head | 140 m |
| System pressure | 10 bar |
| Temperature | 110 °C |

However, the maximum allowable pressures and temperatures depend strongly on the selected materials and components. Also working conditions may cause differences. For more detailed information see chapter 10 "Technical data".

2.7 Re-use

The pump may only be used for other applications after prior consultation with SPXFLOW or your supplier. Since the lastly pumped medium is not always known, the following instructions should be observed:

- 1 Flush the pump properly.
- 2 Make sure the flushing liquid is discharged safely (environment!)



Take adequate precautions and use the appropriate personal protection means like rubber gloves and spectacles!

2.8 Scrapping

If it has been decided to scrap a pump, the same flushing procedure as described for Re-use should be followed.

3 Installation

3.1 Safety

- Read this manual carefully prior to installation and commissioning. Non-observance of these instructions can result in serious damage to the pump and this will not be covered under the terms of our guarantee. Follow the instructions given step by step.
- Ensure that the pump can not be started if work has to be undertaken to the pump during installation and the rotating parts are insufficiently guarded.
- Depending on the design the pumps are suitable for liquids with a temperature of up to 110°C. When installing the pump unit to work at 65°C and above the user should ensure that appropriate protection measures and warnings are fitted to prevent contact with the hot pump parts.
- If there is danger of static electricity, the entire pump unit must be earthed.
- If the pumped liquid is harmful to men or the environment, take appropriate measures to drain the pump safely. Possible leakage liquid from the shaft seal should also be discharged safely.

3.2 Preservation

In order to prevent corrosion, the inside of the pump is treated with a preserving agent before leaving the factory.

Before commissioning the pump remove any preserving agents and flush the pump thoroughly with hot water.

3.3 Environment

- The foundation must be hard, level and flat.
- The area in which the pump is installed must be sufficiently ventilated. An ambient temperature or air humidity which is too high, or a dusty environment, can have a detrimental effect on the operation of the electric motor.
- There should be sufficient space around the pump unit to operate and if necessary repair it.
- Above the cooling air inlet of the motor there must be a free area of at least 1/4 of the electric motor diameter, to ensure unobstructed air supply.

3.4 Mounting

3.4.1 Assembling a pump unit

If the pump and the electric motor still have to be assembled, do the following:

- 1 Remove the front guards (0270). Check if there is a key in both shaft ends.
- 2 Clean the motor and pump shaft. Grease both shaft ends with mounting grease.
- 3 Mount the flattened coupling part on the pump shaft (2200). Keep the coupling part in line with the pump shaft end and fasten the coupling with the locking screw.

! For pumps of bearing bracket 4 this coupling half needs to be pre-heated first!

- 4 Fix the other coupling half on the motor shaft.
- 5 Place the electric motor on the flange (0260). Secure the electric motor with bolts and nuts (0850). Push the coupling half on the motor shaft upward.

➤ *Wherever possible use a hoisting machine and the crane hooks on the electric motor.*

- 6 Mount the distance sleeve on the lower coupling half (n.a. for K2).
- 7 Push the upper coupling half downward. For the correct distance between the coupling halves, see figure 3 with the corresponding table. Then secure the coupling half on the motor shaft.
- 8 Check whether the coupling can be turned by hand. Check the alignment, see paragraph 3.4.3 "Alignment of the coupling".
- 9 Mount the guards.

3.4.2 Installation of a pump unit

Pump and motor shafts of complete pump units are adjusted perfectly in line in the works.

- 1 In case of permanent arrangement place the base plate level on the foundation with the aid of shims.
- 2 Carefully tighten the nuts on the foundation bolts.
- 3 Check the alignment of pump and motor shafts and if necessary realign, see paragraph 3.4.3 "Alignment of the coupling".

3.4.3 Alignment of the coupling

- 1 Use bolts (0890) to position the electric motor in such a way that the coupling halves are aligned correctly.
- 2 Place a ruler (A) on the coupling. The ruler should touch both coupling halves over the entire length, see figure 3

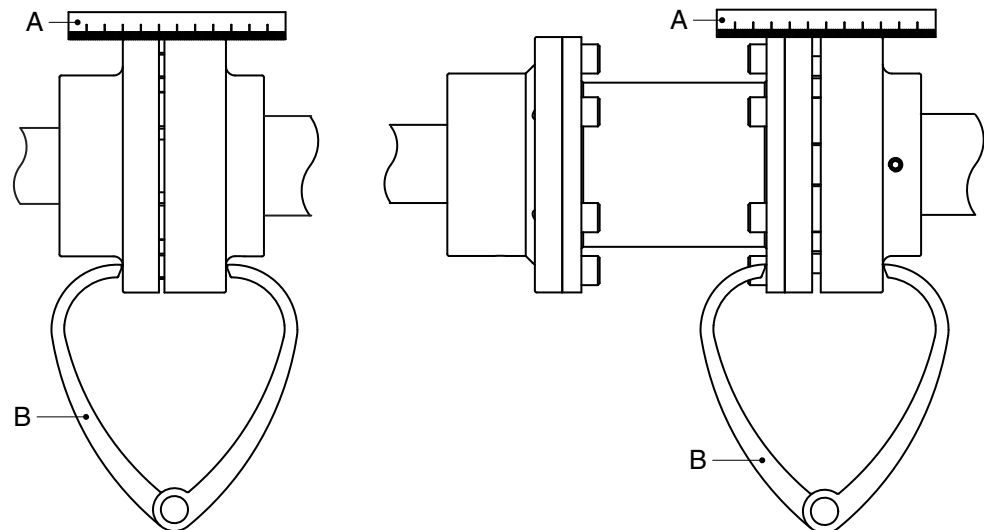

Figure 3: Aligning the coupling by means of a ruler and a pair of outside calipers.

- 3 Repeat the same check on both sides of the coupling at the height of the shaft. Move the electric motor so that the straight edge touches both coupling halves over the entire length.
- 4 Check the alignment once again using a pair of external callipers (B) at 2 diametrical opposite points on the sides of the coupling halves, see figure 3.
- 5 Fit the guard.

3.4.4 Tolerances for aligning the coupling

The maximum allowable tolerances for the alignment of the coupling halves are shown in Table 3. See also figure 4.

Table 3: Alignment tolerances

| External diameter of coupling [mm] | V | | | | Va _{max} - Va _{min} [mm] | Vr _{max} [mm] |
|------------------------------------|----------|----|----------|----|--|------------------------|
| | min [mm] | | max [mm] | | | |
| 81-95 | 2 | 5* | 4 | 6* | 0,15 | 0,15 |
| 96-110 | 2 | 5* | 4 | 6* | 0,18 | 0,18 |
| 111-130 | 2 | 5* | 4 | 6* | 0,21 | 0,21 |
| 131-140 | 2 | 5* | 4 | 6* | 0,24 | 0,24 |
| 141-160 | 2 | 6* | 6 | 7* | 0,27 | 0,27 |
| 161-180 | 2 | 6* | 6 | 7* | 0,30 | 0,30 |
| 181-200 | 2 | 6* | 6 | 7* | 0,34 | 0,34 |
| 201-225 | 2 | 6* | 6 | 7* | 0,38 | 0,38 |
| 225-250 | 3 | 7* | 8 | 9* | 0,42 | 0,42 |
| 251-280 | 3 | 7* | 8 | 9* | 0,47 | 0,47 |

*) = coupling with spacer

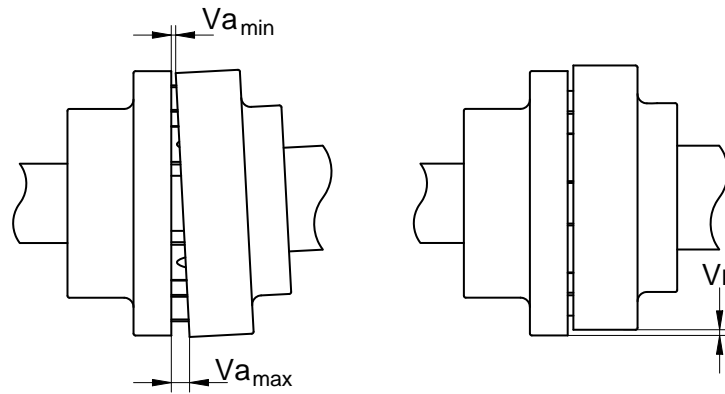

Figure 4: Alignment tolerances standard coupling.

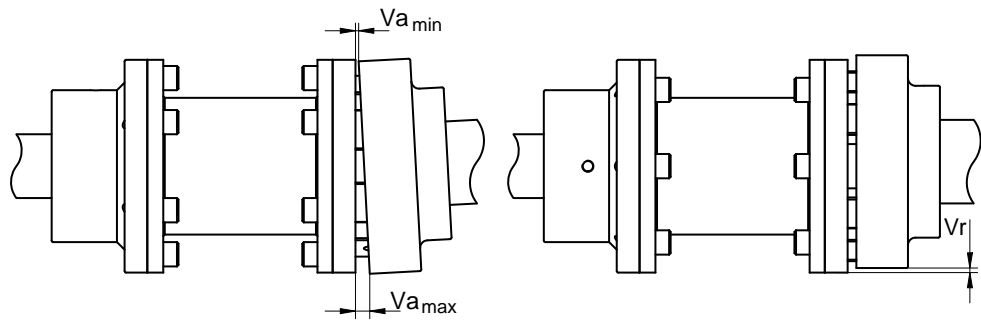

Figure 5: Alignment tolerances spacer coupling.

3.5 Piping

- The piping to the suction and delivery connections must fit exactly and must not be subject to stress during operation.
- The passage of the suction pipe must be amply dimensioned. This pipe should be as short as possible and run towards the pump in such a way that no air pockets can arise. If this is not possible, a venting facility should be provided at the highest point of the pipe.
- If the inside diameter of the suction pipe is larger than the suction connection of the pump, an eccentric reducer should be applied to prevent air pockets and whirls. See figure 6.

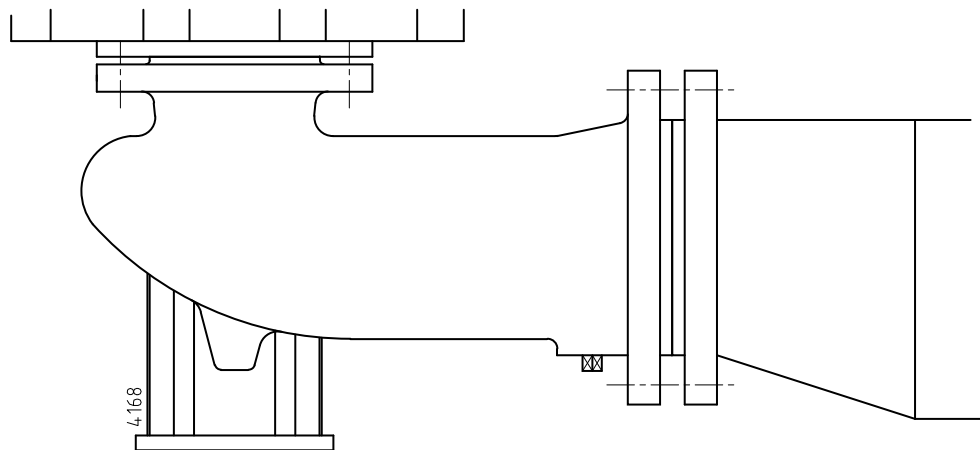

Figure 6: Eccentric reducer to suction flange.

- Sudden changes in the rate of flow can lead to high pressure impulses in the pump and the piping (water shock). Therefore, do not use quick-acting closing devices, valves etc.

3.6 Accessories

- If necessary, fit a foot valve at the bottom of the suction pipe. Combine this foot valve with a suction strainer to prevent impurities from being drawn in.
- When mounting, place temporarily (for the first 24 operating hours) a fine gauze between suction flange and suction pipe so as to prevent internal pump parts from being damaged by foreign matter. If the risk of damage continues to exist, fit a permanent filter.
- Fit any parts that may have been supplied separately.
- In case the pump is provided with an isolation, special attention has to be paid To temperature limits of shaft seal and bearing.

3.7 Connection of the electric motor



The electric motor must be connected to the mains by an approved electrician, according to the locally prevailing regulations of the electricity company.

- Refer to the instruction manual belonging to the electric motor.
- If possible, fit a working switch as close as possible to the pump.

4 Commissioning

4.1 Inspection of the pump

Check whether the pump shaft turns freely. Do this by turning the shaft end at the coupling a few times by hand.

4.2 Inspection of the motor

Check whether the fuses have been mounted.

4.3 Preparing the pump unit for commissioning

Proceed as follows, both when the unit is put into operation for the first time and after the pump has been overhauled:

- 1 Fully open the stop valve in the suction pipe. Close the delivery stop valve.
- 2 Fill the pump and the suction pipe with the liquid to be pumped.
- 3 Turn the pump shaft a few times by hand and add more liquid, if necessary.
- 4 Bearing group 4: De-aerate the pump on the spot of the mechanical seal by partially loosening plug (0340)! Tighten the plug as soon as the liquid exposes.

4.4 Checking the sense of rotation



Beware of possible non-screened rotating parts, when checking the sense of rotation!

- 1 The sense of rotation of the pump is indicated by an arrow. Check whether the sense of rotation of the motor corresponds with that of the pump.
- 2 Let the motor run for only a short time and check the sense of rotation.
- 3 If the sense of rotation is **not** correct, alter the sense of rotation. See the instructions in the user manual belonging to the electric motor.
- 4 Fit the guard.

4.5 Start-up

- 1 Start the pump.
- 2 As soon as the pump is under pressure, slowly open the delivery stop valve until the working pressure is attained.



Make sure that when a pump is running, rotating parts are always properly screened off by the guard!

4.6 Pump in operation

When the pump is in operation, pay attention to the following:

- The pump should never run dry.
- Never use a stop valve in the suction line to control pump output. The stop valve should always be fully opened during operation.
- Check whether the absolute inlet pressure is sufficient, to prevent vaporization in the pump.
- Check whether the pressure difference between suction and delivery side corresponds with the specifications of the pump's duty point.
- The mechanical seal may never show visible leakage.

4.7 Noise

The noise production of a pump depends to a great extent on the operating conditions. The values stated in paragraph 10.7 "Noise data" are based on normal operation of the pump, driven by an electric motor. In case the pump is driven by a combustion engine, or in case it is used outside the normal operation area, as well as in case of cavitation, the noise level may exceed 85 dB(A). In that case precautions should be taken, like building a noise-barrier around the unit or wearing hearing protection.

5 Maintenance

5.1 Daily maintenance

Regularly check the outlet pressure.



No water should get into the terminal box of the electric motor when the pump room is sprayed clean!

Never spray water on hot pump parts! The sudden cooling down may cause them to burst and hot water may flow out!



Flawed maintenance will result in shorter lifespan, possible break down and in any event loss of warranty.

5.2 Mechanical seal

A mechanical seal generally requires no maintenance, however, **it should never be allowed to run dry**. If there are no problems, do not dismantle the mechanical seal. As the seal faces have run in on one another dismantling usually implicates replacement of the mechanical seal. If a mechanical seal shows any leakage it has to be replaced.

5.3 Lubrication of the bearings

The bearings requires re-greasing **after every 8000 hours of operation**. The bearings are filled with grease during assembly. In case the pump is overhauled, the bearing house and the bearings have to be cleaned and provided with new grease. For recommended greases see paragraph 10.1 "Grease".

5.4 Environmental influences

- Regularly clean the filter in the suction pipe or the suction strainer at the bottom of the suction pipe, as the inlet pressure may become too low if the filter or the suction strainer is fouled.
- If there is a risk that the pumped liquid expands during solidification or freezing, the pump has to be drained and, if necessary, flushed after it has been put out of service.
- If the pump is out of service for a long time, it has to be preserved and stored on a vibration-free foundation.
- Check motor for accumulation of dust or dirt, which might influence motor temperature.

5.5 Noise

If a pump starts making noise, this may point to certain problems with the pump unit. A crackling noise can indicate cavitation or excessive motor noise can indicate deterioration of the bearings.

5.6 Motor

Check motor specifications for start-stop frequency.

5.7 Faults



The pump, of which you want to determine the fault, may be hot or under pressure. Take the appropriate precautions first and protect yourself with the proper safety devices (safety goggles, gloves, protective clothing)!

To determine the source of the malfunctioning of the pump, proceed as follows:

- 1 Switch off the power supply to the pump unit. Lock the working switch with a padlock or remove the fuse. In case of a combustion engine: switch off the engine and close the fuel supply to the engine.
- 2 Close the stop valves.
- 3 Determine the nature of the fault.
- 4 Try to determine the cause of the fault with chapter 6 "Problem solving" and take the appropriate measures or contact your installer.

6 Problem solving

Faults in a pump installation can have various causes. The fault may not be in the pump, it may also be caused by the pipe system or the operating conditions. Firstly, always check that installation has been executed in accordance with the instructions in this manual and that the operating conditions still correspond with the specifications for which the pump was purchased.

In general, breakdowns in a pump installation are attributable to the following causes:

- Faults with the pump.
- Breakdowns or faults in the pipe system.
- Faults due to incorrect installation or commissioning.
- Faults due to incorrect choice of pump.

A number of the most frequently occurring failures as well as their possible causes are shown in the table below.

Table 4: Most frequently occurring failures.

| Most common faults | Possible causes, see Table 4. |
|---|--|
| Pump delivers no liquid | 1 2 3 4 8 9 10 11 13 14 17 19 20 21 29 |
| Pump has insufficient volume flow | 1 2 3 4 8 9 10 11 13 14 15 17 19 20 21 28 29 |
| Pump has insufficient head | 2 4 13 14 17 19 28 29 |
| Pump stops after start up | 1 2 3 4 8 9 10 11 |
| Pump has higher power consumption than normal | 12 15 16 17 18 22 23 24 25 26 27 32 34 38 39 |
| Pump has lower power consumption than normal | 13 14 15 16 17 18 20 21 28 29 |
| Mechanical seal has to be replaced to often | 23 25 26 30 32 33 |
| Pump vibrates or is noisy | 1 9 10 11 15 18 19 20 22 23 24 25 26 27 29 37 38 39 40 |
| Bearings wear too much or become hot | 23 24 25 26 27 37 38 39 40 42 |
| Pump running rough hot or seizes | 23 24 25 26 27 37 38 39 40 42 |

Table 5: Possible causes of pump failures.

| | Possible causes |
|----|--|
| 1 | Pump or suction pipe is not sufficiently filled or de-aerated |
| 2 | Gas or air coming from the liquid |
| 3 | Air lock in the suction pipe |
| 4 | Air leak in the suction pipe |
| 8 | The manometric suction head is too high |
| 9 | Suction pipe or suction strainer is blocked |
| 10 | Insufficient immersion of foot valve or suction pipe during operation of the pump |
| 11 | NPSH available too low |
| 12 | Speed too high |
| 13 | Speed too low |
| 14 | Wrong sense of rotation |
| 15 | Pump does not operate at the right duty point |
| 16 | Liquid density differs from the calculated liquid density |
| 17 | Liquid viscosity differs from the calculated liquid viscosity |
| 18 | Pump operates when the liquid flow is too low |
| 19 | Wrong pump selection |
| 20 | Obstruction in impeller or pump casing |
| 21 | Obstruction in the piping |
| 22 | Wrong installation of the pump unit |
| 23 | Pump and motor not well aligned |
| 24 | Rotating part running out of true |
| 25 | Imbalance in rotating parts (for instance: impeller or coupling) |
| 26 | Pump shaft is running out of true |
| 27 | Bearings faulty or worn out |
| 28 | Wear ring faulty or worn out |
| 29 | Damaged impeller |
| 30 | Shaft sleeve on the spot of the packing rings or seal faces of the mechanical seal are worn out or damaged |
| 32 | Not well packed stuffing box packing or bad mounting of the mechanical seal |
| 33 | Stuffing box packing type or mechanical seal not suitable for the pumped liquid or operation circumstances |
| 37 | Axial retaining of impeller or pump shaft is defective |
| 38 | The bearings have been mounted wrongly |
| 39 | Too much or too little bearing lubrication |
| 40 | Wrong or polluted lubricant |
| 42 | Too high axial force because of worn dorsal blades or excessive inlet pressure |

7 Disassembly and assembly

7.1 Precautionary measures



Take adequate measures to avoid that the motor is started while you are working on the pump. This is especially important for electric motors with remote control:

- Switch the operating switch near the pump (if available) to "OFF".
- Switch off the pump switch on the switchboard.
- If necessary remove the fuses.
- Hang a danger board near the switchboard cabinet.

7.2 Special tools

Assembly and disassembly work requires no special tools. However, such tools can make certain jobs easier, for instance replacing the shaft seal. If such is the case it will be indicated in the text.

7.3 Designation of parts

7.3.1 Position numbers

The position numbers used in the descriptions below refer to the figures shown in the description. These numbers are also used in the general cross section drawings and the corresponding parts lists in chapter 9 "Parts".

7.3.2 Constructive variants

The pumps can be supplied in various constructive variants. Each variant has a code which is stated in the type identification on the name plate on the pump.

Assembly with motor:

| | |
|-----------|--|
| K1 | Flexible coupling with distance sleeve. |
| K2 | Short version with flexible coupling. |
| K3 | Flexible coupling with distance sleeve and welded lantern piece. |
| K4 | Flexible coupling with welded lantern piece. |

Pumps can be supplied with or without suction bend (0400) and foot pads (0410).

7.3.3 Draining

! **Make sure no liquid gets into the environment!**

Before starting any disassembly the pump should be drained through the drain plug (0320). If possible, also drain the suction bend to a certain extent (if provided with a suction bend (0400) through drain plug (0350)). Wherever necessary, first close possible valves in the suction and delivery pipe. If the pump processes harmful liquids, take the following precautions:

- 1 Wear protective gloves, shoes, glasses, etc.
- 2 Flush the pump properly.
- 3 Make sure no liquid gets into the environment.
- 4 Refit the drain plug.

7.4 **Disassembly and assembly Top Pull Out unit**

➤ *The Top Pull Out unit and the electric motor of large pumps are too heavy to be lifted by hand. Use appropriate hoisting equipment.*

- CombiFlex K1 type pumps use a Top Pull Out system. For that reason they are provided with a "spacer"-coupling. The intermediate piece of this coupling can be removed. After that the pump cover with the entire rotating part can be removed. This way the pump can be dismantled to a major extent without having to loosen the suction and delivery piping. The motor can remain in its position.
- CombiFlex K2 type pumps have a flexible coupling. Before disassembly the motor and the flange (0260) have to be removed in order to be able to remove the pump cover.
- CombiFlex K3 and K4 type pumps have to have the motor and the lantern removed before disassembly of the rotating part.

7.4.1 Disassembly Top Pull Out unit, version K1

- 1 Remove the aluminium guard (0270), respectively the protective steel sheets (0270).
- 2 Loosen the pipe coupling (1430) and remove the flushing pipe (1420) for the mechanical seal.
- 3 Remove the distance sleeve (0210) from the spacer coupling.
- 4 Mark the position of the pump cover (0110) in relation to the pump casing (0100).
- 5 Remove the Allen screws (0800) and lift the Top Pull Out unit out of the pump through the opening between the rods c.q. lantern elements (0250).

7.4.2 Assembly Top Pull Out unit, version K1

- 1 Mount a new gasket (0300) for the pump casing and lower the Top Pull Out unit in the right position into the pump casing. Take care not to damage the gasket (0300).
- 2 Tighten the Allen screws (0800) crosswise.
- 3 Reconnect the flushing pipe (1420) for the mechanical seal (which had been disconnected) between the delivery flange and the pump cover.
- 4 Mount the intermediate piece of the spacer coupling (0210).
- 5 Check the alignment of pump and motor shaft, see paragraph 3.4.3 "Alignment of the coupling". If necessary they have to be realigned.
- 6 Mount the aluminium guard (0270), respectively the protective steel sheets (0270).

7.4.3 Disassembly Top Pull Out unit, version K2

- 1 Loosen the coupling guard (0270).
- 2 Remove the bolts (0850) and nuts (0851) of the electric motor.
- 3 Lift the electric motor from the pump.
- 4 Loosen the sunk head screws (0810) and remove the flange (0260).
- 5 Mark the position of the pump cover (0110) in relation to the pump casing (0100). Disconnect the flushing pipe (1420) for the mechanical seal.
- 6 Remove the Allen screws (0800) and lift the Top Pull Out unit out of the pump.

7.4.4 Assembly Top Pull Out unit, version K2

- 1 Mount a new gasket (0300) for the pump casing and lower the Top Pull Out unit in the right position into the pump casing. Take care not to damage the gasket (0300).
- 2 Tighten the Allen screws (0800) crosswise.
- 3 Reconnect the flushing pipe (1420) for the mechanical seal between the delivery flange and the pump cover.
- 4 Mount the flange (0260) by means of the sunk head screws (0810).
- 5 Mount the electric motor by means of bolts (0850) and nuts (0851).
- 6 Check the alignment of pump and motor shaft, see paragraph 3.4.3 "Alignment of the coupling". If necessary they have to be realigned.
- 7 Mount the coupling guard (0270).

7.4.5 Disassembly Top Pull Out unit, versions K3 and K4

- 1 Remove the protective steel sheets (0270).
- 2 Loosen the pipe couplings (1430) and remove the flushing pipe (1420) for the mechanical seal.
- 3 K3: Remove the distance sleeve (0210) from the spacer coupling.
- 4 Loosen bolts (0850) and nuts (0851) and remove the electric motor.
- 5 Loosen Allen screws (0820) and washers (0825) and remove the lantern piece (0250).
- 6 Mark the position of the pump cover (0110) in relation to the pump casing (0100).
- 7 Remove the Allen screws (0800) and washers (0805) and lift the Top Pull Out unit out of the pump.

➤ *Pumps of Bearing group 4 have lifting provisions on the pump cover in order to lift the Top Pull Out unit vertically until the impeller is entirely out of the pump casing.*

7.4.6 Assembly Top Pull Out unit, versions K3 and K4

1 Mount a new gasket (0300) for the pump casing and lower the Top Pull Out unit in the right position into the pump casing. Take care not to damage the gasket (0300).

➤ *Pumps of Bearing group 4 have lifting provisions on the pump cover in order to lower the Top Pull Out unit vertically until the impeller is in the pump casing.*

2 Mount the Allen screws (0800) and washers (0805) and tighten the Allen screws crosswise.

3 Mount the lantern piece (0250) and fix it with Allen screws (0820) and washers (0825).

4 Mount the electric motor and fix it with bolts (0850), washers (0855) and nuts (0851).

5 Reconnect the flushing pipe (1420) for the mechanical seal between the delivery flange and the pump cover.

6 K3: Mount the intermediate piece of the spacer coupling (0210).

7 Check the alignment of pump and motor shaft, see paragraph 3.4.3 "Alignment of the coupling". If necessary they have to be realigned.

8 Mount the protective steel sheets (0270).

7.5 Replacement the impeller and the wear ring

The play between the impeller and the wear ring is 0,3 mm to the diameter at delivery. In case the play has increased to 0,5-0,7 mm due to wear, the impeller and the wear ring should be replaced.

7.5.1 Disassembly of the impeller

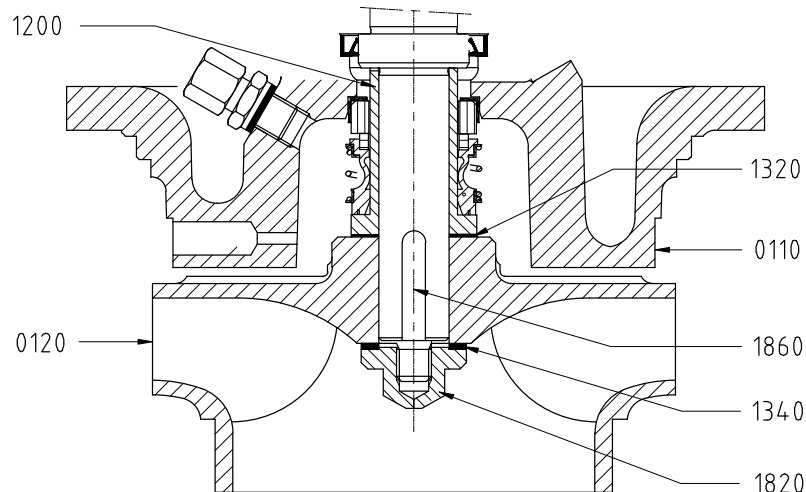

Figure 7: Disassembly of the impeller.

The item numbers used are referring to figure 7.

- 1 Remove the Top Pull Out unit, see paragraph 7.4 "Disassembly and assembly Top Pull Out unit".
- 2 Remove the cap nut (1820) and the gasket (1340). Sometimes the nut has to be heated to break the Loctite-contact.
- 3 Pumps of bearing bracket 4: Heat the impeller with a torch.
- 4 Remove the impeller (0120) with a pulley puller, or wrest the impeller by inserting for instance 2 big screwdrivers between the impeller and the pump cover (0110).
- 5 Remove the gasket (1320).
- 6 Remove the impeller key(s) (1860).

7.5.2 Mounting the impeller

- 1 Place the impeller key (1860) in the key way of the pump shaft. Some types have 2 keys.
- 2 Fit the gasket (1320).
- 3 Push the impeller onto the pump shaft.
- 4 Degrease the thread on the pump shaft and the thread in the cap nut.
- 5 Fit the gasket (1340)
- 6 Put a drop of Loctite 243 on the thread and fit the cap nut. For tightening moment of the cap nut see paragraph 10.4.2 "Tightening moments for cap nut".

7.5.3 Disassembling the wear ring

After removing the Top Pull Out unit the wear ring can be removed. In most cases the ring has been fixed so tightly that it cannot be removed undamaged.

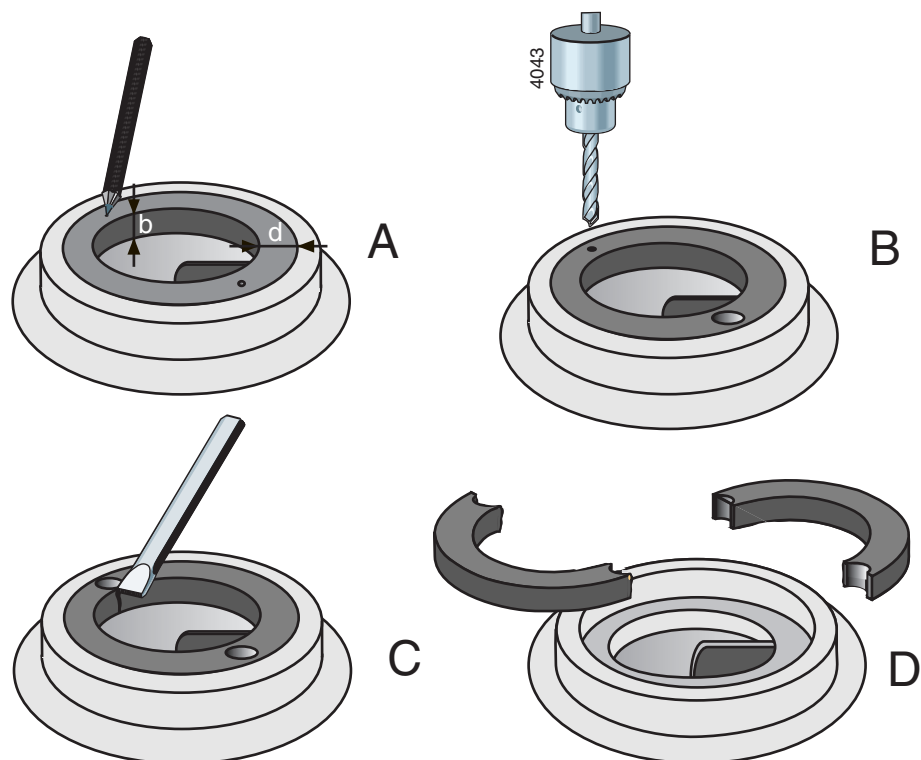

Figure 8: Removal of wear ring.

- 1 Measure the thickness (d) and the width (b) of the ring, see figure 8 A.
- 2 Make a centre hole in the middle of the edge of the ring at two opposite points, see figure 8 B.
- 3 Use a drill with a diameter just a little bit smaller than the thickness (d) of the ring and drill two holes in the ring, see figure 8 C. Don't drill deeper than the width (b) of the ring. Take care not to damage the fitting edge of the pump casing.
- 4 Use a chisel to cut the remaining part of the ring thickness. Now you can remove the ring in two parts from the pump casing, see figure 8 D.
- 5 Clean the pump casing and carefully remove all bore dust and metal splinters.

7.5.4 Assembling the wear ring

- 1 Clean and degrease the fitting edge of the pump casing where the wear ring is to be mounted.
- 2 Degrease the outer edge of the wear ring and put a few drops of Loctite 641 on it.
- 3 Fit the wear ring in the pump casing. **Take care it is not pushed out of alignment!**

7.6 Mechanical seal

7.6.1 Instructions for mounting a mechanical seal

➤ *First read the following instructions regarding the mounting of a mechanical seal. Follow these instructions closely when mounting a mechanical seal.*

- **Leave the assembly of a mechanical seal with PTFE (Teflon) covered O-rings to a specialist.** These rings are easily damaged during assembly.
- A mechanical seal is a fragile precision instrument. Leave the seal in its original packing until you are ready to fit it!
- Clean all receiving parts properly. Make sure your hands and working environment are clean!
- **Never touch the sliding surfaces with ones fingers!**
- Take care not to damage the seal during assembly. Never put the rings down on their sliding surfaces!

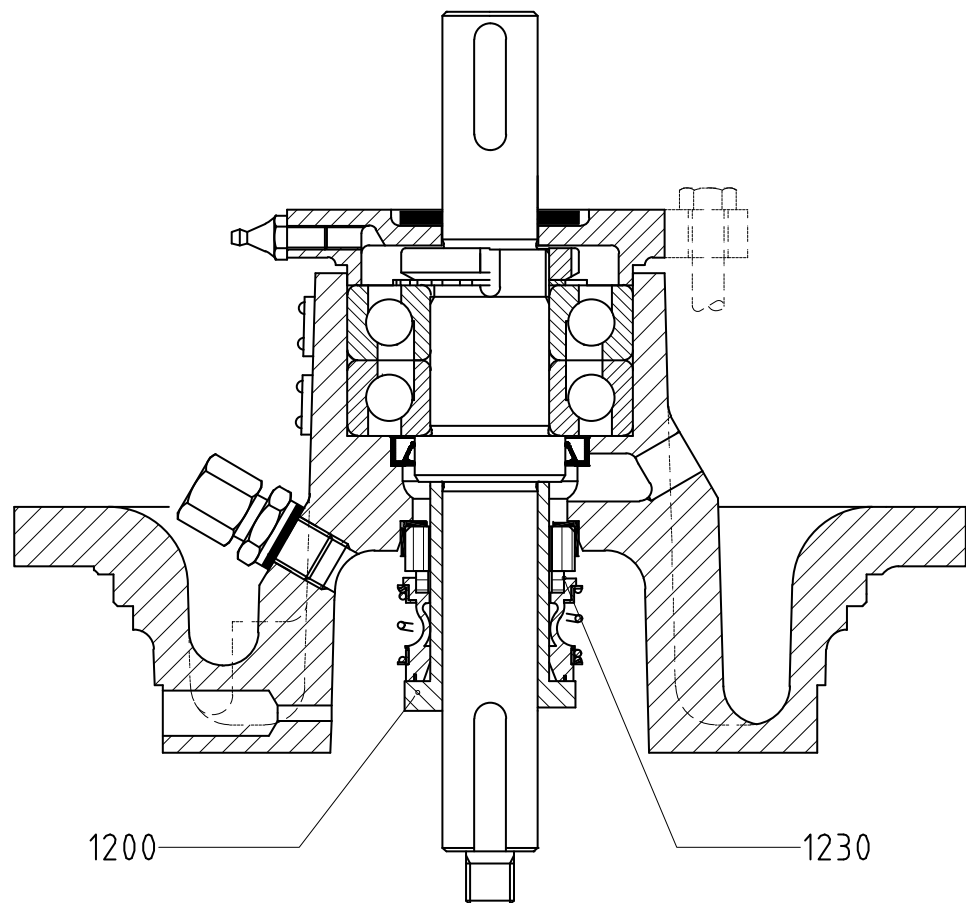

Figure 9: Disassembly of the mechanical seal.

7.6.2 Disassembly of the mechanical seal

The item numbers used are referring to figure 9.

- 1 Remove the impeller, see paragraph 7.5.1 "Disassembly of the impeller".
- 2 (Only for Bearing group 4:) Apply some glycerin or silicon spray on the pump shaft to facilitate the removal of the shaft sleeve. Cover the key way with a strip of adhesive tape to prevent the O-ring (1905) from getting damaged during disassembly.
- 3 Pull the shaft sleeve (1200) from the pump shaft.
- 4 Pull the rotating part of the shaft seal (1230) from the shaft sleeve.
- 5 Pull the counter-ring of the mechanical seal out of the pump cover.

7.6.3 Assembly of the mechanical seal

- 1 Check if the shaft sleeve (1200) and (if present) the O-ring (1905) are not damaged. Replace any damaged parts.
- 2 Put the pump cover flat down and press the counter-ring of the seal straight into it. If necessary, use a plastic pressure piece. **Never hammer it inside!** The maximum axial turn of the counter-ring is 0,1 mm.
- 3 Push the rotating part of the seal onto the shaft sleeve. Put some glycerine or silicon spray on the O-ring or the bellows to facilitate the assembly.
- 4 (Only for Bearing group 4:) Apply some glycerin or silicon spray on the pump shaft to facilitate the assembly of the shaft sleeve. Cover the key way with a strip of adhesive tape to prevent the O-ring (1905) from getting damaged during assembly.
- 5 Push the shaft sleeve (1200) onto the pump shaft.
- 6 Mount the impeller, see paragraph 7.5.2 "Mounting the impeller".

7.7 Bearing

7.7.1 Instructions for assembly and disassembly of bearings

➤ *First read the following instructions regarding assembly and disassembly. Follow these instructions closely when assembling and disassembling bearings.*

Disassembly:

- Use **a proper puller** to remove the bearings from the pump shaft.
- If no proper puller is available, carefully knock at the inner raceway of the bearing. Use an ordinary hammer and a mild steel drift for this.
Never knock at the bearing with a hammer!

Assembly:

- Make sure your working place is clean.
- Leave the bearings in their original packing as long as possible.
- Slightly oil the pump shaft and the other relevant parts before assembly.
- **Preheat the bearings to 90°C** before mounting them on the pump shaft.
- If preheating is not possible: knock the bearing onto the pump shaft. **Never knock at the bearing directly!** Use a mounting bush positioned against the inner raceway of the bearing and a normal hammer (a soft hammer might loose some splinters which could damage the bearing).
- **Always apply a new locking washer (2380) when assembling bearings!**

7.7.2 Disassembly of bearings, bearing brackets 1, 2 and 3

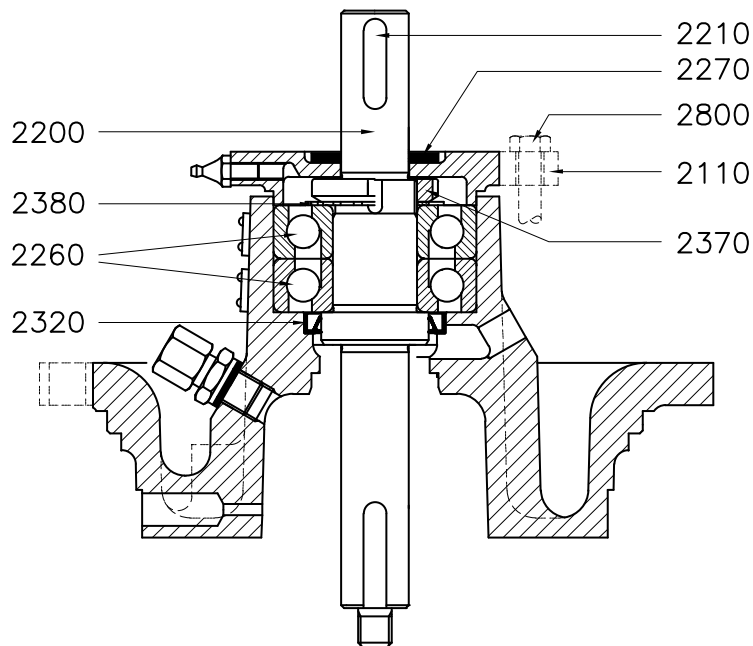

Figure 10: Disassembly bearings of bearing brackets 1, 2 and 3.

The item numbers used are referring to figure 10.

- 1 Disassemble the impeller and the shaft seal, see paragraph 7.5.1 "Disassembly of the impeller" and paragraph 7.6.2 "Disassembly of the mechanical seal"
- 2 Remove the key (2210) and the splash ring (2270).
- 3 Remove the hexagon bolts (2800) and the bearing cover (2110).
- 4 Knock the pump shaft (2200) on the impeller side to loosen the bearings from their seats. Use a plastic hammer to avoid damaging the thread.
- 5 Knock the tab of the locking washer (2380) straight and loosen the lock nut (2370). Remove the bearings (2260) from the pump shaft.
- 6 Remove the oil catcher (2320).

7.7.3 Assembly of bearings, bearing brackets 1, 2 and 3

- 1 Clean the inside of the bearing bracket properly.
- 2 Preheat the bearings and mount them on the pump shaft. Make sure the bearings are mounted straight. Watch the position of the bearings: they are mounted in O-arrangement. Make sure the bearings are mounted straight and push them firmly against the shaft shoulder. Let the bearings cool down!
- 3 Mount the locking washer (2380) and screw the lock nut (2370) on the pump shaft. Tighten the nut. For the correct tightening moment see chapter 10 "Technical data". Secure it by knocking a tab of the locking washer into the opening of the lock nut.
- 4 Put some grease on the ball races of the bearings, see chapter 10 "Technical data" for recommended greases. Then mount the oil catcher (2320) on the pump shaft.
- 5 Mount the shaft with the bearings in the bearing bracket. Knock the shaft end on the coupling side until the lower bearing lies against the bottom of the seating. The shaft with the bearings should be entered straight into the bearing bracket.
- 6 Mount the bearing cover (2110) and the splash ring (2270).
- 7 Mount the shaft seal and the impeller as described in paragraph 7.6 "Mechanical seal" and paragraph 7.5.2 "Mounting the impeller".

7.7.4 Disassembly of bearings 200-400, 250-250, 250-315, 300-250, 300-315

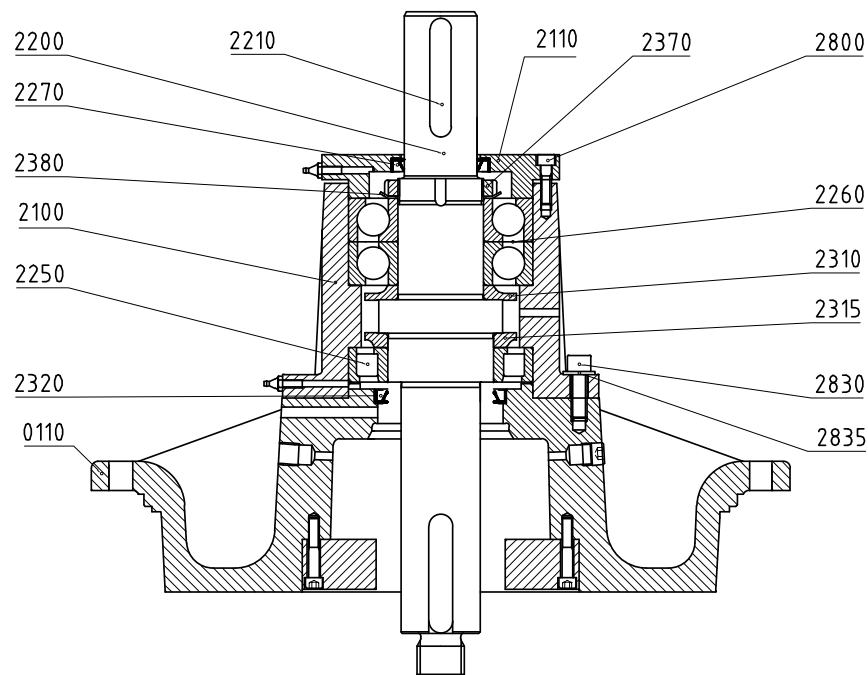

Figure 11: Disassembly bearings 200-400, 250-250, 250-315, 300-250, 300-315.

The item numbers used are referring to figure 11.

- 1 Disassemble the impeller and the shaft seal, see paragraph 7.5.1 "Disassembly of the impeller" and paragraph 7.6.2 "Disassembly of the mechanical seal"
- 2 Loosen the Allen screws (2830) and disassemble the bearing bracket (2100). Remove the sealing ring (2270)
- 3 Remove the key (2210).
- 4 Loosen the Allen screws (2800) and remove the bearing cover (2110).
- 5 Knock on the pump shaft (2200) on the impeller side to loosen the angular contact bearings (2260) from their seats. Use a plastic hammer to avoid damaging the thread. Remove the pump shaft with the bearings from the bearing bracket.
- 6 Knock the tab of the locking washer (2380) straight and loosen the lock nut (2370). Remove the angular contact bearings (2260) and the grease control disk (2310) from the pump shaft.
- 7 Remove the inner ring of the cylindrical roller bearing (2250) and the grease control disk (2315) from the pump shaft.
- 8 Remove the outer ring and the roller ring from the bearing bracket.
- 9 Remove the oil catcher (2320) from the pump cover (0110).

- 7.7.5 Assembly of bearings 200-400, 250-250, 250-315, 300-250, 300-315
- 1 Clean the inside of the bearing bracket properly.
 - 2 Mount both the grease control disks (2310 and 2315) on the pump shaft (2200). The large side must face the shaft shoulder.
 - 3 Preheat the angular contact bearings and the inner ring of the cylindrical roller bearing and mount them on the pump shaft. Watch the position of the bearings: they are mounted in X-arrangement. Make sure the bearings are mounted straight and push them, together with the grease control disks, firmly against the shaft shoulder. Let the bearings cool down!
 - 4 Mount the locking washer (2380) and screw the lock nut (2370) on the pump shaft. Tighten the nut. For the correct tightening moment see chapter 10 "Technical data". Secure it by knocking a tab of the locking washer into the opening of the lock nut.
 - 5 Put some grease on the ball races of the bearings, see chapter 10 "Technical data" for recommended greases.
 - 6 Mount the shaft with the bearings in the bearing bracket. Knock the shaft end on the coupling side until the backward angular contact bearing lies against the bottom of the seating. The shaft with the bearings should be entered straight into the bearing bracket.
 - 7 Put some grease on the roller race of the cylindrical roller bearing, see chapter 10 "Technical data" for the recommended greases. Mount the roller ring and the outer ring of the cylindrical roller bearing. These should go straight into the bearing bracket.
 - 8 Push the sealing ring (2270) into the bearing cover (2110) and mount the bearing cover with Allen screws (2800).
 - 9 Push the sealing ring (2320) into the pump cover (0110) and mount the bearing bracket (2100) onto the pump cover with Allen screws (2830) and washers (2835).
 - 10 Mount the shaft seal and the impeller as described in paragraph 7.6 "Mechanical seal" and paragraph 7.5.2 "Mounting the impeller"

7.7.6 Disassembly of bearings 150B-400, 150-500, 200-250, 200-315

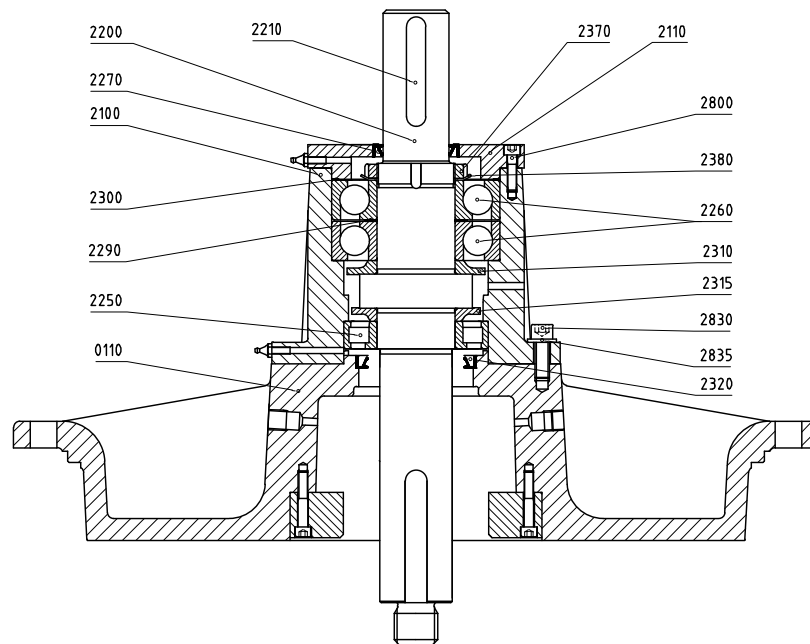

Figure 12: Disassembly bearings 150B-400, 150-500, 200-250, 200-315.

The item numbers used are referring to figure 12.

- 1 Disassemble the impeller and the shaft seal, see paragraph 7.5.1 "Disassembly of the impeller" and paragraph 7.6.2 "Disassembly of the mechanical seal".
- 2 Loosen the Allen screws (2830) and disassemble the bearing bracket (2100). Remove the sealing ring (2270)
- 3 Remove the key (2210).
- 4 Loosen the Allen screws (2800) and remove the bearing cover (2110).
- 5 Remove the wave washer (2300).
- 6 Knock on the pump shaft (2200) on the impeller side to loosen the angular contact bearings (2260) from their seats. Use a plastic hammer to avoid damaging the thread. Remove the pump shaft with the bearings from the bearing bracket.
- 7 Knock the tab of the locking washer (2380) straight and loosen the lock nut (2370). Remove the angular contact bearings (2260), the adjusting ring (2290) and the grease control disk (2310) from the pump shaft.
- 8 Remove the inner ring of the cylindrical roller bearing (2250) and the grease control disk (2315) from the pump shaft.
- 9 Remove the outer ring and the roller ring from the bearing bracket.
- 10 Remove the oil catcher (2320) from the pump cover (0110).

- 7.7.7 Assembly of bearings 150B-400, 150-500, 200-250, 200-315
- 1 Clean the inside of the bearing bracket properly.
 - 2 Mount both the grease control disks (2310 and 2315) on the pump shaft (2200). The large side must face the shaft shoulder.
 - 3 Preheat the angular contact bearings and the inner ring of the cylindrical roller bearing.
 - 4 Mount the inner ring of the cylindrical roller bearing on the pump shaft and push it, together with the grease control disk, firmly against the shaft shoulder. Let the bearing cool down!
 - 5 Mount one angular contact bearing on the pump shaft, mount the adjusting ring (2290) on the pump shaft and mount the other angular contact bearing. Watch the position of both angular contact bearings: they are mounted in X-arrangement. Push them, together with the grease control disk, firmly against the shaft shoulder. Let the bearings cool down!
 - 6 Mount the locking washer (2380) and screw the lock nut (2370) on the pump shaft. Tighten the nut. For the correct tightening moment see chapter 10 "Technical data". Secure it by knocking a tab of the locking washer into the opening of the lock nut.
 - 7 Put some grease on the ball races of the bearings, see chapter 10 "Technical data" for recommended greases.
 - 8 Mount the shaft with the bearings in the bearing bracket. Knock the shaft end on the coupling side until the backward angular contact bearing lies against the bottom of the seating. The shaft with the bearings should be entered straight into the bearing bracket.
 - 9 Put some grease on the roller race of the cylindrical roller bearing, see chapter 10 "Technical data" for the recommended greases. Mount the roller ring and the outer ring of the cylindrical roller bearing. These should go straight into the bearing bracket.
 - 10 Mount the wave washer (2300) on the pump shaft.
 - 11 Push the sealing ring (2270) into the bearing cover (2110) and mount the bearing cover with Allen screws (2800). Take care the wave washer is properly positioned against the outer ring of the bearing!
 - 12 Push the sealing ring (2320) into the pump cover (0110) and mount the bearing bracket (2100) onto the pump cover with Allen screws (2830) and washers (2835).
 - 13 Mount the shaft seal and the impeller as described in paragraph 7.6 "Mechanical seal" and paragraph 7.5.2 "Mounting the impeller".

7.7.8 Disassembly of bearings 125-500

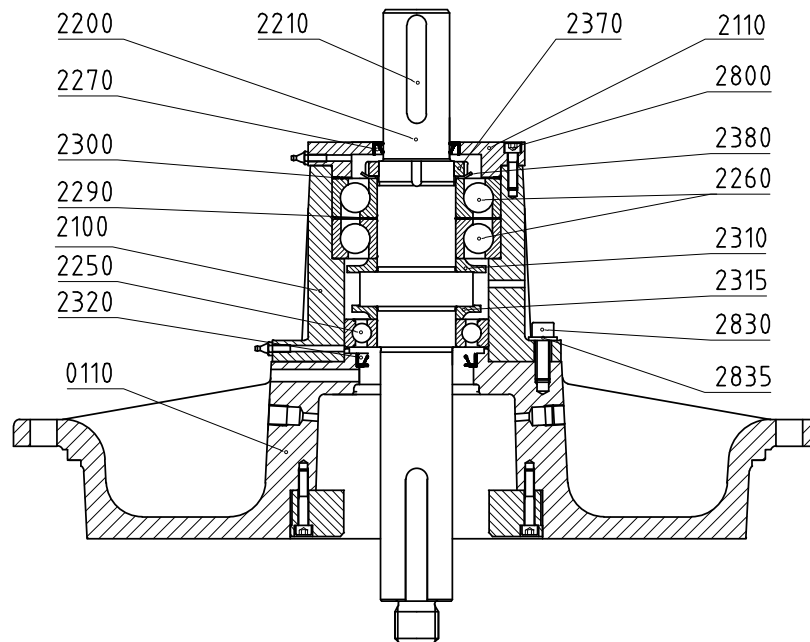

Figure 13: Disassembly bearings 125-500.

The item numbers used are referring to figure 13.

- 1 Disassemble the impeller and the shaft seal, see paragraph 7.5.1 "Disassembly of the impeller" and paragraph 7.6.2 "Disassembly of the mechanical seal".
- 2 Loosen the Allen screws (2830) and disassemble the bearing bracket (2100). Remove the sealing ring (2270)
- 3 Remove the key (2210).
- 4 Loosen the Allen screws (2800) and remove the bearing cover (2110).
- 5 Remove the wave washer (2300).
- 6 Knock on the pump shaft (2200) on the impeller side to loosen the angular contact bearings (2260) from their seats. Use a plastic hammer to avoid damaging the thread. Remove the pump shaft with the bearings from the bearing bracket.
- 7 Knock the tab of the locking washer (2380) straight and loosen the lock nut (2370). Remove the angular contact bearings (2260), the adjusting ring (2290) and the grease control disk (2310) from the pump shaft.
- 8 Remove the ball bearing (2250) and the grease control disk (2315) from the pump shaft.
- 9 Remove the oil catcher (2320) from the pump cover (0110).

7.7.9 Assembly of bearings 125-500

- 1 Clean the inside of the bearing bracket properly.
- 2 Mount both the grease control disks (2310 and 2315) on the pump shaft (2200). The large side must face the shaft shoulder.
- 3 Preheat the angular contact bearings and the inner ring of the cylindrical roller bearing.
- 4 Mount the ball bearing on the pump shaft and push it, together with the grease control disk, firmly against the shaft shoulder. Let the bearing cool down!
- 5 Mount one angular contact bearing on the pump shaft, mount the adjusting ring (2290) on the pump shaft and mount the other angular contact bearing. Watch the position of both angular contact bearings: they are mounted in X-arrangement. Push them, together with the grease control disk, firmly against the shaft shoulder. Let the bearings cool down!
- 6 Mount the locking washer (2380) and screw the lock nut (2370) on the pump shaft. Tighten the nut. For the correct tightening moment see chapter 10 "Technical data". Secure it by knocking a tab of the locking washer into the opening of the lock nut.
- 7 Put some grease on the ball races of the bearings, see chapter 10 "Technical data" for recommended greases.
- 8 Mount the shaft with the bearings in the bearing bracket. Knock the shaft end on the coupling side until the backward angular contact bearing lies against the bottom of the seating. The shaft with the bearings should be entered straight into the bearing bracket.
- 9 Mount the wave washer (2300) on the pump shaft.
- 10 Push the sealing ring (2270) into the bearing cover (2110) and mount the bearing cover with Allen screws (2800). Take care the wave washer is properly positioned against the outer ring of the bearing!
- 11 Push the sealing ring (2320) into the pump cover (0110) and mount the bearing bracket (2100) onto the pump cover with Allen screws (2830) and washers (2835).
- 12 Mount the shaft seal and the impeller as described in paragraph 7.6 "Mechanical seal" and paragraph 7.5.2 "Mounting the impeller".

8 Dimensions

8.1 Dimensions delivery flange

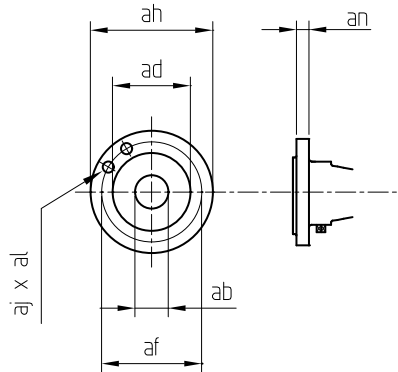

Figure 14: Dimensions delivery flange.

8.1.1 Dimensions delivery flange K1, K2

| ISO 7005 PN16 | | | | | |
|---------------|-----|-----|-----|---------|----|
| ab | ad | af | ah | aj x al | an |
| 32 | 78 | 100 | 140 | 4 x 18 | 18 |
| 40 | 88 | 110 | 150 | 4 x 18 | 18 |
| 50 | 102 | 125 | 165 | 4 x 18 | 20 |
| 65 | 122 | 145 | 185 | 4 x 18 | 20 |
| 80 | 138 | 160 | 200 | 8 x 18 | 22 |
| 100 | 158 | 180 | 220 | 8 x 18 | 22 |
| 125 | 188 | 210 | 250 | 8 x 18 | 24 |
| 150 | 212 | 240 | 285 | 8 x 23 | 24 |

| ISO 7005 PN10 | | | | | |
|---------------|-----|-----|-----|---------|----|
| ab | ad | af | ah | aj x al | an |
| 200 | 268 | 295 | 340 | 8 x 23 | 26 |
| 250 | 320 | 350 | 395 | 12 x 23 | 28 |

8.1.2 Dimensions delivery flange K3, K4

| ISO 7005 PN10 (an ISO 7005 PN 16) | | | | | |
|-----------------------------------|-----|-----|-----|---------|----|
| ab | ad | af | ah | aj x al | an |
| 125 | 184 | 210 | 250 | 8 x 19 | 26 |
| 150 | 211 | 240 | 285 | 8 x 23 | 26 |
| 200 | 266 | 295 | 340 | 8 x 23 | 30 |
| 250 | 319 | 350 | 395 | 12 x 23 | 32 |
| 300 | 370 | 400 | 445 | 12 x 23 | 32 |

8.2 Dimensions suction flange

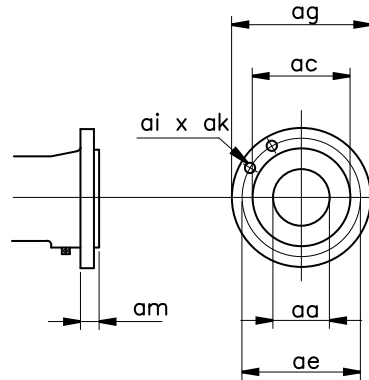

Figure 15: Dimensions suction flange.

8.2.1 Dimensions suction flange K1, K2

| ISO 7005 PN16 | | | | | |
|---------------|-----|-----|-----|---------|----|
| aa | ac | ae | ag | ai x ak | am |
| 65 | 122 | 145 | 185 | 4 x 18 | 20 |
| 80 | 138 | 160 | 200 | 8 x 18 | 22 |
| 100 | 158 | 180 | 220 | 8 x 18 | 22 |
| 125 | 188 | 210 | 250 | 8 x 18 | 24 |
| 150 | 212 | 240 | 285 | 8 x 22 | 24 |

| ISO 7005 PN10 | | | | | |
|---------------|-----|-----|-----|---------|----|
| aa | ac | ae | ag | ai x ak | am |
| 200 | 268 | 295 | 340 | 8 x 22 | 31 |
| 250 | 320 | 350 | 395 | 12 x 22 | 26 |

8.2.2 Dimensions suction flange K3, K4

| ISO 7005 PN10 (an ISO 7005 PN 16) | | | | | |
|-----------------------------------|-----|-----|-----|---------|----|
| aa | ac | ae | ag | ai x ak | am |
| 200 | 266 | 295 | 340 | 8 x 23 | 30 |
| 250 | 319 | 350 | 395 | 12 x 23 | 32 |
| 300 | 370 | 400 | 445 | 12 x 23 | 32 |

8.3 Dimensions foot pads K1, K2

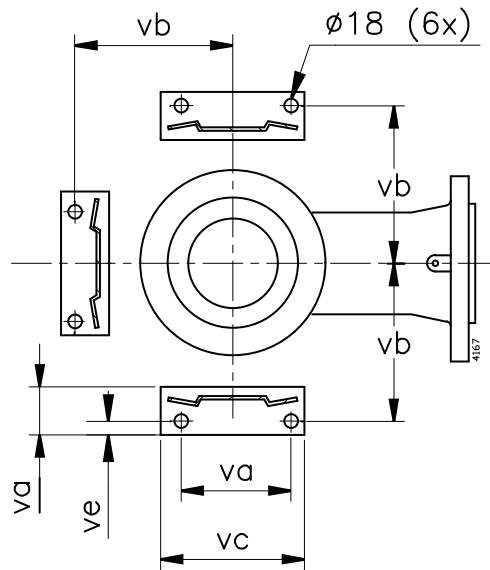

Figure 16: Dimensions foot pads (Top view).

| | va | vb | vc | vd | ve |
|---------|-----------|-----------|-----------|-----------|-----------|
| ...-160 | 120 | 180 | 160 | 80 | 19 |
| ...-200 | 130 | 205 | 180 | 80 | 17 |
| ...-250 | 155 | 230 | 205 | 80 | 20 |
| ...-315 | 175 | 255 | 220 | 80 | 18 |
| ...-400 | 220 | 310 | 270 | 80 | 18 |

8.4 Dimensions foot pads 200-200 / 250B-315 K1, K2

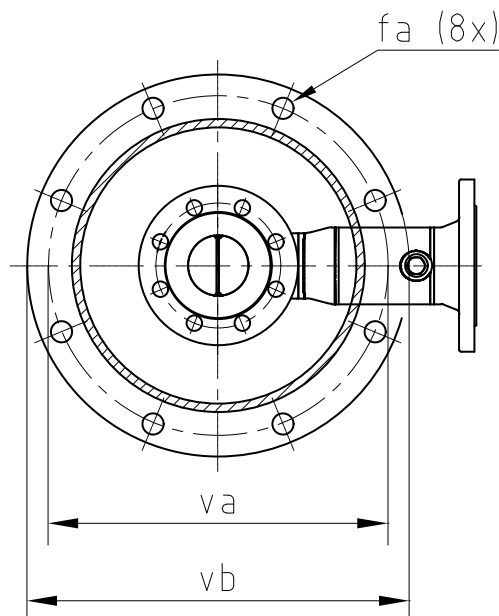

Figure 17: Dimensions foot pads (Top view).

| | va | vb | fa |
|----------|-----------|-----------|-----------|
| 200-200 | 555 | 600 | 18 |
| 250B-315 | 600 | 650 | 18 |

8.5 Pump dimensions K1

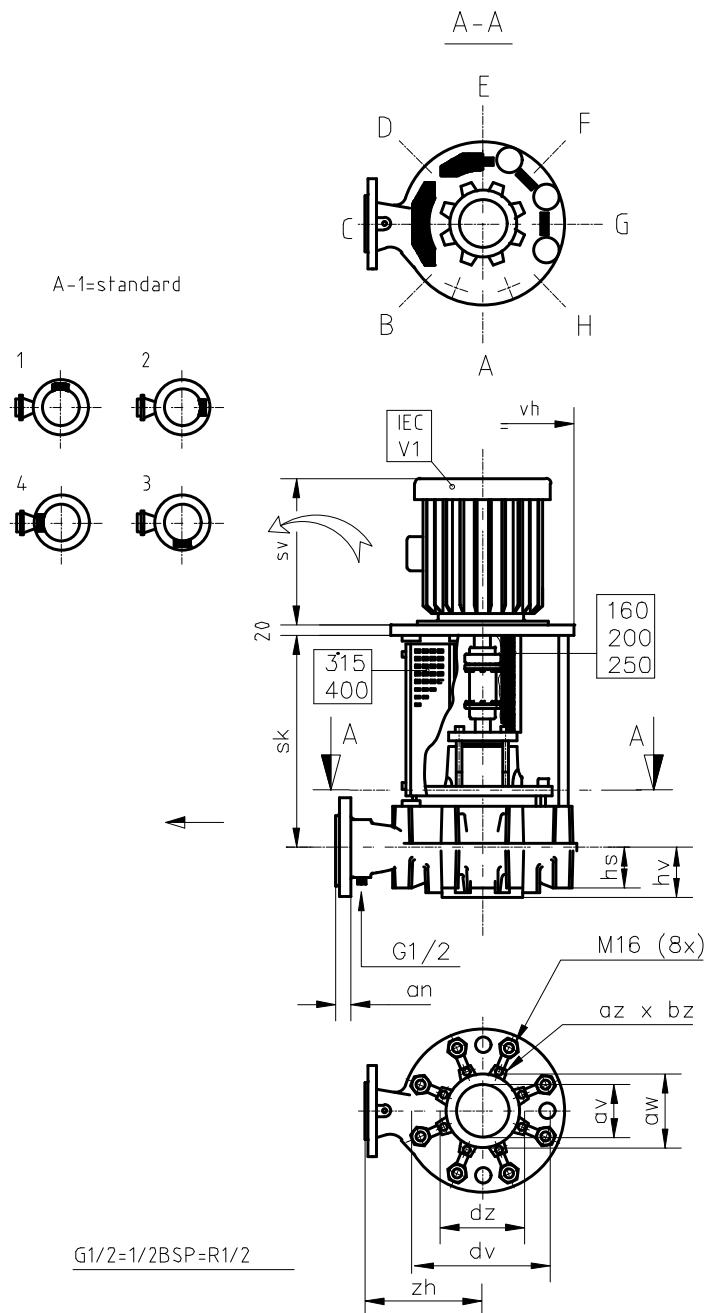

Figure 18: Pump dimensions K1.

Standard:

- disassembly opening lantern: pos A
- junction box electric motor: pos 1

| | ab | av | dv | hs | hv | zh | sk | | | |
|-----------|-----|-----|-----|-----|-----|-----|-----------------------------|--------|--------------------------|--------------------------|
| | | | | | | | 80 90S/L 100L 112M | 132S/M | 160M/L 180M/L 200L | 225S/M 250M 280S/M |
| 32-160 | 32 | 50 | 290 | 35 | 65 | 250 | 340 | 355 | | |
| 32-200 | 32 | 65 | 340 | 35 | 65 | 280 | 340 | 355 | 385 | |
| 40-160 | 40 | 65 | 290 | 35 | 65 | 250 | 340 | 355 | 385 | |
| 40-200 | 40 | 65 | 340 | 35 | 80 | 280 | 340 | 355 | 385 | |
| 40-250 | 40 | 80 | 400 | 35 | 80 | 315 | 340 | 355 | 385 | |
| 50-160 | 50 | 65 | 290 | 50 | 80 | 250 | 340 | 360 | 385 | |
| 50-200 | 50 | 80 | 340 | 35 | 80 | 280 | 340 | 355 | 385 | |
| 50-250 | 50 | 80 | 400 | 35 | 80 | 315 | 340 | 355 | 385 | |
| 65-160 | 65 | 100 | 290 | 80 | 100 | 250 | 340 | 360 | 385 | |
| 65-200 | 65 | 100 | 340 | 60 | 80 | 280 | 340 | 360 | 385 | |
| 65A-250 | 65 | 100 | 400 | 35 | 100 | 315 | 440 | 460 | 490 | 520 |
| 65-315 | 65 | 100 | 450 | 55 | 100 | 315 | 440 | 460 | 490 | |
| 80-160 | 80 | 125 | 290 | 95 | 80 | 250 | 340 | 360 | 390 | |
| 80-200 | 80 | 125 | 340 | 85 | 100 | 280 | 440 | 460 | 490 | 520 |
| 80(A)-250 | 80 | 125 | 400 | 65 | 100 | 315 | 440 | 460 | 490 | 520 |
| 80-315 | 80 | 125 | 450 | 55 | 100 | 315 | 440 | 460 | 490 | |
| 80-400 | 80 | 125 | 570 | 75 | 100 | 405 | | 525 | 555 | 585 |
| 100C-200 | 100 | 125 | 340 | 100 | 100 | 280 | 440 | 460 | 490 | 520 |
| 100-250 | 100 | 125 | 400 | 85 | 100 | 315 | 440 | 460 | 490 | 520 |
| 100-315 | 100 | 125 | 450 | 75 | 100 | 315 | 440 | 460 | 490 | 520 |
| 100-400 | 100 | 125 | 570 | 75 | 100 | 375 | | 525 | 555 | 585 |
| 125-250 | 125 | 150 | 400 | 105 | 115 | 355 | 440 | 460 | 490 | |
| 125-315 | 125 | 150 | 450 | 95 | 125 | 355 | | 530 | 555 | 585 |
| 125-400 | 125 | 150 | 570 | 75 | 125 | 400 | | 525 | 555 | 585 |
| 150-315 | 150 | 200 | 450 | 120 | 140 | 400 | | 530 | 555 | 585 |
| 150-400 | 150 | 200 | 570 | 120 | 140 | 450 | | | 555 | 585 |
| 200-200 | 200 | 150 | 400 | 150 | 185 | 400 | | 460 | 490 | 490 |
| 250B-315 | 250 | 200 | 450 | 150 | 135 | 500 | | | 560 | 585 |

| (200-200 =.....-250) | vh | | | | | | | | | | | | | | | | |
|-------------------------|------|---------|---------|----------|----------|----------|----------|----------|----------|----------|----------|----------|----------|----------|----------|----------|----------|
| | F165 | | | F215 | | | F265 | | F300 | | | | F350 | F400 | | F500 | |
| sv max | 262 | 333 | 333 | 365 | 385 | 426 | 426 | 535 | 535 | 627 | 665 | 737 | 790 | 790 | 815 | 833 | 918 |
| CF | 80 | 90 S | 90 L | 100 L | 112 M | 132 S | 132 M | 160 M | 160 L | 180 M | 180 L | 200 L | 225 S | 225 M | 250 M | 280 S | 280 M |
| ...-160 | 350 | 350 | 350 | 350 | 350 | 350 | | 350 | 350 | 350 | | 400 | | | | | |
| ...-200 | 400 | 400 | 400 | 400 | 400 | 400 | 400 | 400 | 400 | 400 | | 400 | | 450 | 550 | 550 | |
| ...-250 | 450 | 450 | 450 | 450 | 450 | 450 | 450 | 450 | 450 | 450 | 450 | 450 | | 450 | 550 | 550 | 550 |
| ...-315 | | | | 550 | 550 | 550 | 550 | 550 | 550 | 550 | 550 | 550 | 550 | 550 | 550 | 550 | 550 |
| ...-400 | | | | | | 620 | 620 | 620 | 620 | 620 | 620 | 620 | 620 | 620 | 620 | 620 | |

| av | aw | az x bz | dz |
|-----|-----|---------|-----|
| 50 | 102 | 4 x M16 | 125 |
| 60 | 122 | 4 x M16 | 145 |
| 80 | 138 | 8 x M16 | 160 |
| 100 | 158 | 8 x M16 | 180 |
| 125 | 188 | 8 x M16 | 210 |
| 150 | 212 | 8 x M20 | 240 |
| 200 | 268 | 8 x M20 | 295 |

8.6 Pump dimensions K2

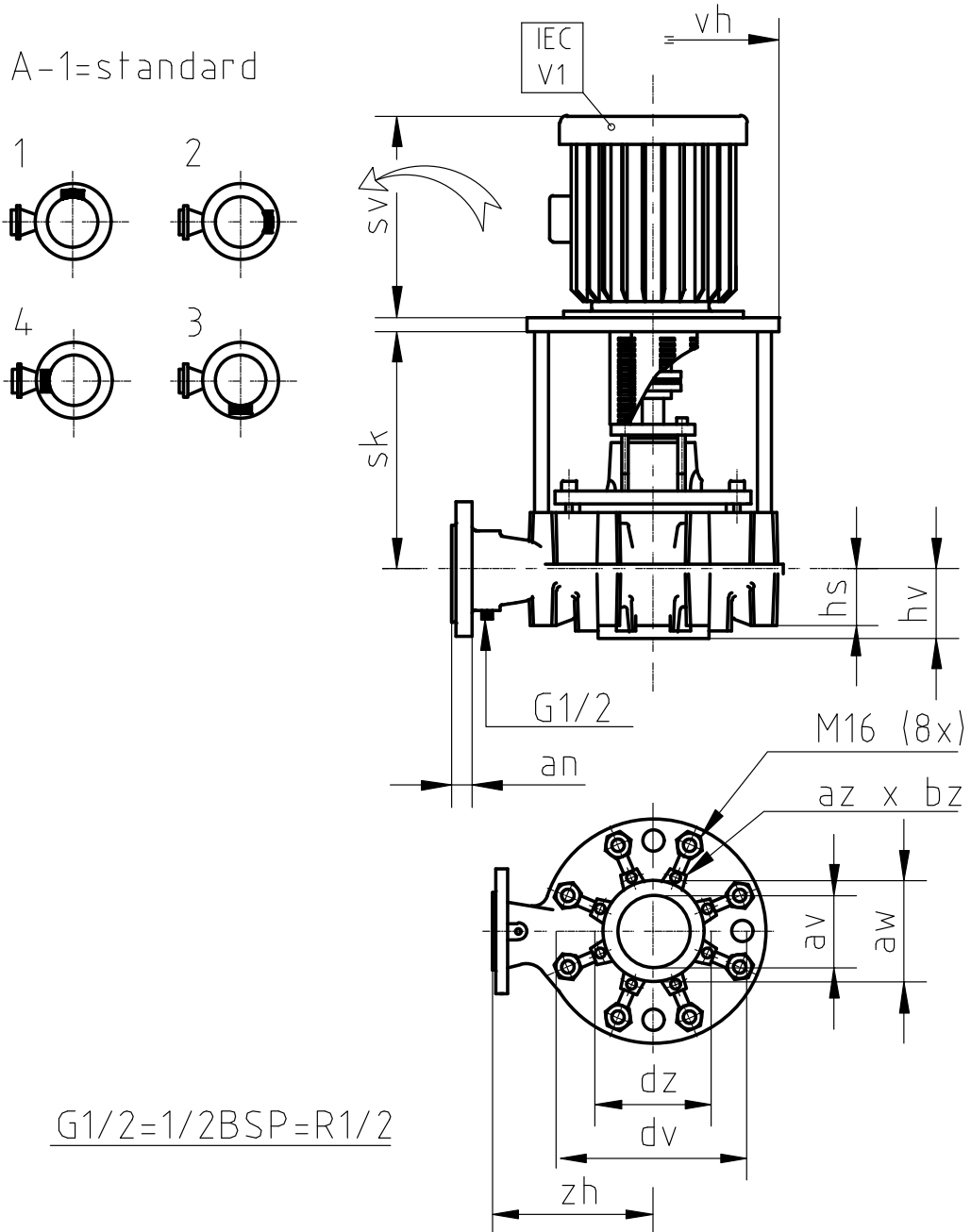

Figure 19: Pump dimensions K2.

Standard:

- disassembly opening lantern: pos A
- junction box electric motor: pos 1

| | ab | av | dv | hs | hv | zh | sk | | | | | | | |
|-----------|-----|-----|-----|-----|-----|-----|-----|-------|--------------|--------|------------------|------|--------|----------------|
| | | | | | | | 80 | 90S/L | 100L 112M | 132S/M | 160M/L 180M/L | 200L | 225S/M | 250M 280S/M |
| 32-160 | 32 | 50 | 290 | 35 | 65 | 250 | 225 | 235 | 250 | 270 | | | | |
| 32-200 | 32 | 65 | 340 | 35 | 65 | 280 | 225 | 235 | 250 | 270 | 300 | | | |
| 40-160 | 40 | 65 | 290 | 35 | 65 | 250 | 225 | 235 | 250 | 270 | 300 | | | |
| 40-200 | 40 | 65 | 340 | 35 | 80 | 280 | 225 | 235 | 250 | 270 | 300 | | | |
| 40-250 | 40 | 80 | 400 | 35 | 80 | 315 | 225 | 235 | 250 | 270 | 300 | | | |
| 50-160 | 50 | 65 | 290 | 50 | 80 | 250 | 225 | 235 | 245 | 265 | 300 | | | |
| 50-200 | 50 | 80 | 340 | 35 | 80 | 280 | 225 | 235 | 250 | 270 | 300 | 300 | | |
| 50-250 | 50 | 80 | 400 | 35 | 80 | 315 | 225 | 235 | 250 | 270 | 300 | 300 | | |
| 65-160 | 65 | 100 | 290 | 80 | 100 | 250 | 225 | 235 | 245 | 265 | 300 | 300 | | |
| 65-200 | 65 | 100 | 340 | 60 | 80 | 280 | 225 | 235 | 245 | 265 | 300 | 300 | | |
| 65A-250 | 65 | 100 | 400 | 35 | 100 | 315 | | 295 | 305 | 325 | 355 | 355 | 390 | |
| 65-315 | 65 | 100 | 450 | 55 | 100 | 315 | | 295 | 310 | 325 | 360 | | | |
| 80-160 | 80 | 125 | 290 | 95 | 80 | 250 | | 235 | 245 | 265 | 300 | 300 | | |
| 80-200 | 80 | 125 | 340 | 85 | 100 | 280 | | 295 | 305 | 325 | 355 | 355 | 385 | 385 |
| 80(A)-250 | 80 | 125 | 400 | 65 | 100 | 315 | | 295 | 305 | 325 | 355 | 355 | 390 | 390 |
| 80-315 | 80 | 125 | 450 | 55 | 100 | 315 | | | 310 | 325 | 360 | 360 | | |
| 80-400 | 80 | 125 | 570 | 75 | 100 | 405 | | | | 390 | 425 | 425 | 455 | |
| 100C-200 | 100 | 125 | 340 | 100 | 100 | 280 | | | 305 | 325 | 355 | 355 | 385 | 385 |
| 100-250 | 100 | 125 | 400 | 85 | 100 | 315 | | | 305 | 325 | 355 | 355 | 385 | 385 |
| 100-315 | 100 | 125 | 450 | 75 | 100 | 315 | | | 310 | 325 | 360 | 360 | 390 | |
| 100-400 | 100 | 125 | 570 | 75 | 100 | 375 | | | | 390 | 425 | 425 | 455 | 455 |
| 125-250 | 125 | 150 | 400 | 105 | 115 | 355 | | | 305 | 325 | 355 | 355 | | |
| 125-315 | 125 | 150 | 450 | 95 | 125 | 355 | | | | 390 | 425 | 425 | 455 | 455 |
| 125-400 | 125 | 150 | 570 | 75 | 125 | 400 | | | | 390 | 425 | 425 | 455 | 455 |
| 150-315 | 150 | 200 | 450 | 120 | 140 | 400 | | | | 390 | 425 | 425 | 455 | 455 |
| 150-400 | 150 | 200 | 570 | 120 | 140 | 450 | | | | | 425 | 425 | 455 | 455 |
| 200-200 | 200 | 150 | 400 | 150 | 185 | 400 | | | | 325 | 355 | 355 | | |
| 250B-315 | 250 | 200 | 450 | 150 | 135 | 500 | | | | | 420 | 420 | 455 | 455 |

| (200-200 =.....-250) | vh | | | | | | | | | | | | | | | | |
|-------------------------|------|---------|---------|----------|----------|----------|----------|----------|----------|----------|----------|----------|----------|----------|----------|----------|----------|
| | F165 | | | F215 | | | F265 | | F300 | | | | F350 | F400 | | F500 | |
| sv max | 262 | 333 | 333 | 365 | 385 | 426 | 426 | 535 | 535 | 627 | 665 | 737 | 790 | 790 | 815 | 833 | 918 |
| CF | 80 | 90 S | 90 L | 100 L | 112 M | 132 S | 132 M | 160 M | 160 L | 180 M | 180 L | 200 L | 225 S | 225 M | 250 M | 280 S | 280 M |
| ...-160 | 350 | 350 | 350 | 350 | 350 | 350 | | 350 | 350 | 350 | | 400 | | | | | |
| ...-200 | 400 | 400 | 400 | 400 | 400 | 400 | 400 | 400 | 400 | 400 | | 400 | | 450 | 550 | 550 | |
| ...-250 | 450 | 450 | 450 | 450 | 450 | 450 | 450 | 450 | 450 | 450 | 450 | 450 | | 450 | 550 | 550 | 550 |
| ...-315 | | | | 550 | 550 | 550 | 550 | 550 | 550 | 550 | 550 | 550 | 550 | 550 | 550 | 550 | 550 |
| ...-400 | | | | | | 620 | 620 | 620 | 620 | 620 | 620 | 620 | 620 | 620 | 620 | 620 | |

| av | aw | az x bz | dz |
|-----|-----|---------|-----|
| 50 | 102 | 4 x M16 | 125 |
| 60 | 122 | 4 x M16 | 145 |
| 80 | 138 | 8 x M16 | 160 |
| 100 | 158 | 8 x M16 | 180 |
| 125 | 188 | 8 x M16 | 210 |
| 150 | 212 | 8 x M20 | 240 |
| 200 | 268 | 8 x M20 | 295 |

| | aa | ab | zb | zd | zg | zh | sk | | | |
|-----------|-----|-----|-----|-----|-----|-----|-----------------------------|--------|--------------------------|--------------------------|
| | | | | | | | 80 90S/L 100L 112M | 132S/M | 160M/L 180M/L 200L | 225S/M 250M 280S/M |
| 32-160 | 65 | 32 | 167 | 330 | 220 | 250 | 340 | 355 | | |
| 32-200 | 80 | 32 | 177 | 350 | 220 | 280 | 340 | 355 | 385 | |
| 40-160 | 80 | 40 | 177 | 330 | 220 | 250 | 340 | 355 | 385 | |
| 40-200 | 80 | 40 | 192 | 350 | 220 | 280 | 340 | 355 | 385 | |
| 40-250 | 100 | 40 | 202 | 370 | 250 | 315 | 340 | 355 | 385 | |
| 50-160 | 80 | 50 | 192 | 345 | 220 | 250 | 340 | 360 | 385 | |
| 50-200 | 100 | 50 | 202 | 350 | 250 | 280 | 340 | 355 | 385 | |
| 50-250 | 100 | 50 | 202 | 370 | 240 | 315 | 340 | 355 | 385 | |
| 65-160 | 125 | 65 | 242 | 375 | 240 | 250 | 340 | 360 | 385 | |
| 65-200 | 125 | 65 | 222 | 375 | 240 | 280 | 340 | 360 | 385 | |
| 65A-250 | 125 | 65 | 242 | 370 | 240 | 315 | 440 | 460 | 490 | 520 |
| 65-315 | 125 | 65 | 242 | 455 | 240 | 315 | 440 | 460 | 490 | |
| 80-160 | 150 | 80 | 232 | 390 | 350 | 250 | 340 | 360 | 390 | |
| 80-200 | 150 | 80 | 252 | 400 | 350 | 280 | 440 | 460 | 490 | 520 |
| 80(A)-250 | 150 | 80 | 252 | 400 | 350 | 315 | 440 | 460 | 490 | 520 |
| 80-315 | 150 | 80 | 252 | 455 | 350 | 315 | 440 | 460 | 490 | |
| 80-400 | 150 | 80 | 252 | 425 | 350 | 405 | | 525 | 555 | 585 |
| 100C-200 | 150 | 100 | 252 | 415 | 350 | 280 | 440 | 460 | 490 | 520 |
| 100-250 | 150 | 100 | 252 | 420 | 350 | 315 | 440 | 460 | 490 | 520 |
| 100-315 | 150 | 100 | 252 | 475 | 350 | 315 | 440 | 460 | 490 | 520 |
| 100-400 | 150 | 100 | 252 | 425 | 350 | 375 | | 525 | 555 | 585 |
| 125-250 | 150 | 125 | 267 | 440 | 280 | 355 | 440 | 460 | 490 | |
| 125-315 | 150 | 125 | 277 | 495 | 280 | 355 | | 530 | 555 | 585 |
| 125-400 | 150 | 125 | 277 | 425 | 280 | 400 | | 525 | 555 | 585 |
| 150-315 | 200 | 150 | 342 | 520 | 350 | 400 | | 530 | 555 | 585 |
| 150-400 | 200 | 150 | 342 | 520 | 350 | 450 | | | 555 | 585 |

| | vh | | | | | | | | | | | | | | | | |
|---------|------|---------|---------|----------|----------|----------|----------|----------|----------|----------|----------|----------|----------|----------|----------|----------|----------|
| | F165 | | | F215 | | F265 | | F300 | | | | F350 | F400 | | F500 | | |
| sv max | 262 | 333 | 333 | 365 | 385 | 426 | 426 | 535 | 535 | 627 | 665 | 737 | 790 | 790 | 815 | 833 | 918 |
| CF | 80 | 90 S | 90 L | 100 L | 112 M | 132 S | 132 M | 160 M | 160 L | 180 M | 180 L | 200 L | 225 S | 225 M | 250 M | 280 S | 280 M |
| ...-160 | 350 | 350 | 350 | 350 | 350 | 350 | | 350 | 350 | 350 | | 400 | | | | | |
| ...-200 | 400 | 400 | 400 | 400 | 400 | 400 | 400 | 400 | 400 | 400 | | 400 | | 450 | 550 | 550 | |
| ...-250 | 450 | 450 | 450 | 450 | 450 | 450 | 450 | 450 | 450 | 450 | 450 | 450 | | 450 | 550 | 550 | 550 |
| ...-315 | | | | 550 | 550 | 550 | 550 | 550 | 550 | 550 | 550 | 550 | 550 | 550 | 550 | 550 | 550 |
| ...-400 | | | | | | 620 | 620 | 620 | 620 | 620 | 620 | 620 | 620 | 620 | 620 | 620 | |

8.8 Pump dimensions 200-200 / 250B-315 K1, with suction bend

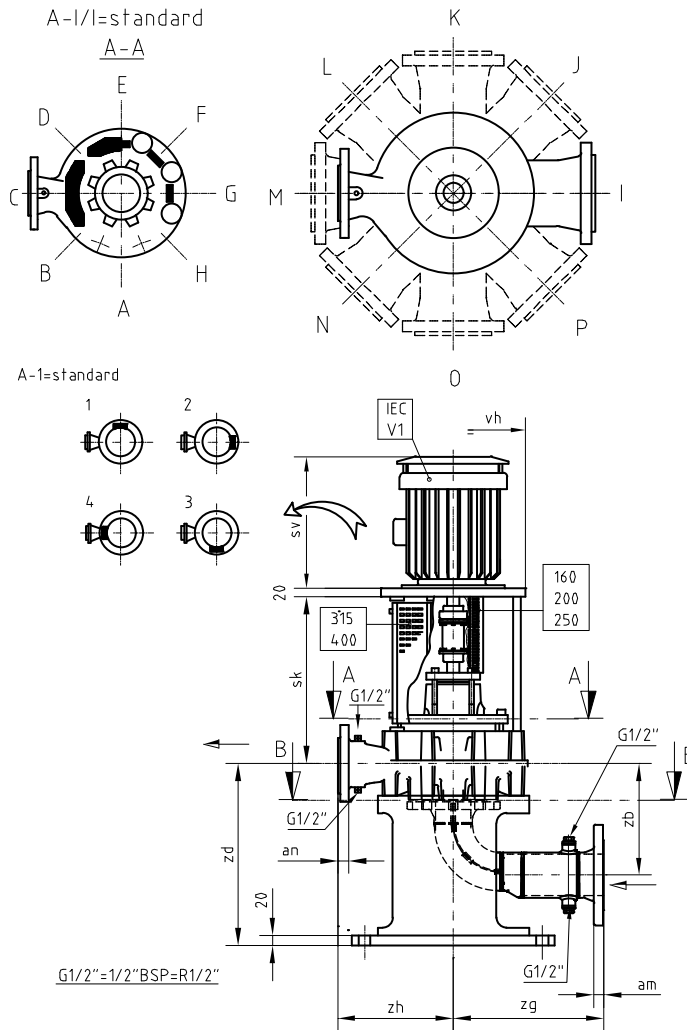

Figure 21: Pump dimensions 200-200 / 250B-315 K1, with suction bend.

Standard:

- suction bend: pos I
- junction box electric motor: pos 1

| | aa | ab | zb | zd | zg | zh | vh | sk | | |
|----------|-----|-----|-----|-----|-----|-----|-----------|--------|----------------------------------|------------------------------------|
| | | | | | | | | 132S/M | 160L 180S/L 200L 225M02 | 225S/M 250M 280S/M 315S/M |
| 200-200 | 200 | 200 | 498 | 700 | 500 | 400 | 18" x 9,5 | 460 | 490 | 490 |
| 250B-315 | 250 | 250 | 533 | 800 | 600 | 500 | 20" x 9,5 | | 560 | 585 |

| | vh | | | | | | | | | | | |
|----------|------|------|------|------|------|------|------|------|------|------|------|------|
| | F265 | | F300 | | | | F350 | F400 | | F500 | | |
| sv max | 426 | 426 | 535 | 535 | 627 | 665 | 737 | 790 | 790 | 815 | 833 | 918 |
| | 132S | 132M | 160M | 160L | 180M | 180L | 200L | 225S | 225M | 250M | 280S | 280M |
| 200-200 | 450 | 450 | 450 | 450 | 450 | 450 | 450 | | 450 | 550 | 550 | 550 |
| 250B-315 | | | 550 | 550 | 550 | 550 | 550 | 550 | 550 | 550 | 550 | 550 |

8.9 Pump dimensions K2, with suction bend

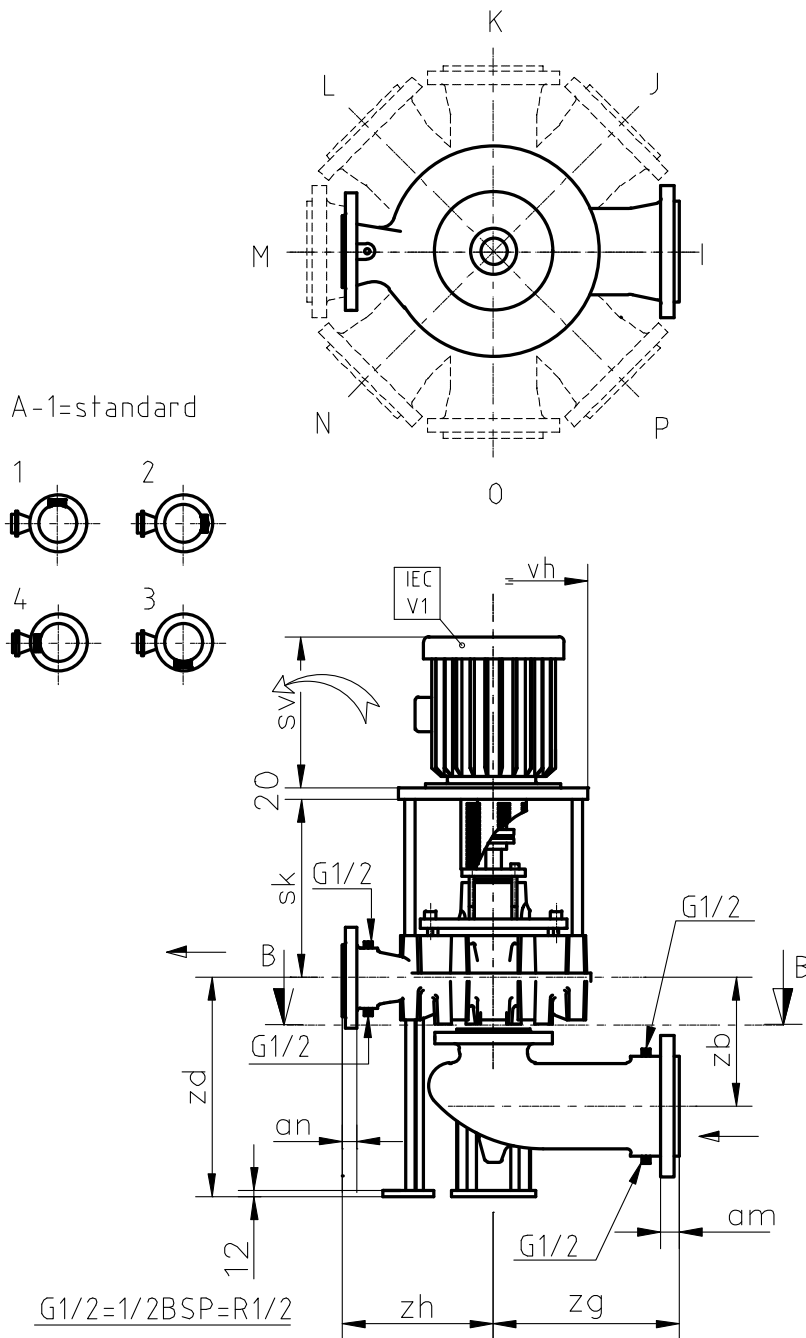

Figure 22: Pump dimensions K2, with suction bend.

Standard:

- disassembly opening lantern: pos A
- suction bend: pos I
- junction box electric motor: pos 1

| | aa | ab | zb | zd | zg | zh | sk | | | | | | | |
|-----------|-----|-----|-----|-----|-----|-----|-----|-------|--------------|--------|------------------|------|--------|----------------|
| | | | | | | | 80 | 90S/L | 100L 112M | 132S/M | 160M/L 180M/L | 200L | 225S/M | 250M 280S/M |
| 32-160 | 65 | 32 | 167 | 330 | 220 | 250 | 235 | 235 | 250 | 290 | | | | |
| 32-200 | 80 | 32 | 177 | 350 | 220 | 280 | 235 | 235 | 250 | 290 | 310 | | | |
| 40-160 | 80 | 40 | 177 | 330 | 220 | 250 | 235 | 235 | 250 | 290 | 310 | | | |
| 40-200 | 80 | 40 | 192 | 350 | 220 | 280 | 235 | 235 | 250 | 290 | 310 | | | |
| 40-250 | 100 | 40 | 202 | 370 | 250 | 315 | 235 | 235 | 250 | 290 | 310 | | | |
| 50-160 | 80 | 50 | 192 | 345 | 220 | 250 | 225 | 245 | 245 | 300 | 300 | | | |
| 50-200 | 100 | 50 | 202 | 350 | 250 | 280 | 235 | 235 | 250 | 290 | 310 | 310 | | |
| 50-250 | 100 | 50 | 202 | 370 | 240 | 315 | 235 | 235 | 250 | 290 | 310 | 310 | | |
| 65-160 | 125 | 65 | 242 | 375 | 240 | 250 | 225 | 245 | 245 | 300 | 300 | 320 | | |
| 65-200 | 125 | 65 | 222 | 375 | 240 | 280 | 225 | 245 | 245 | 300 | 300 | 320 | | |
| 65A-250 | 125 | 65 | 242 | 370 | 240 | 315 | | 295 | 315 | 335 | 355 | 355 | | 355 |
| 65-315 | 125 | 65 | 242 | 455 | 240 | 315 | | 300 | 310 | 330 | 370 | | | |
| 80-160 | 150 | 80 | 232 | 390 | 350 | 250 | | 245 | 245 | 300 | 300 | 320 | | |
| 80-200 | 150 | 80 | 252 | 400 | 350 | 280 | | 305 | 305 | 345 | 365 | 365 | 365 | 385 |
| 80(A)-250 | 150 | 80 | 252 | 400 | 350 | 315 | | 295 | 315 | 335 | 355 | 355 | 355 | 400 |
| 80-315 | 150 | 80 | 252 | 455 | 350 | 315 | | | 310 | 330 | 370 | 370 | | |
| 80-400 | 150 | 80 | 252 | 425 | 350 | 405 | | | | 390 | 425 | 425 | 455 | |
| 100C-200 | 150 | 100 | 252 | 415 | 350 | 280 | | | 305 | 345 | 365 | 365 | 365 | 385 |
| 100-250 | 150 | 100 | 252 | 420 | 350 | 315 | | | 305 | 345 | 365 | 365 | 365 | 385 |
| 100-315 | 150 | 100 | 252 | 475 | 350 | 315 | | | 310 | 330 | 370 | 370 | 415 | |
| 100-400 | 150 | 100 | 252 | 425 | 350 | 375 | | | | 390 | 425 | 425 | 455 | 455 |
| 125-250 | 150 | 125 | 267 | 440 | 280 | 355 | | | 305 | 345 | 365 | 365 | | |
| 125-315 | 150 | 125 | 277 | 495 | 280 | 355 | | | | 390 | 425 | 425 | 455 | 455 |
| 125-400 | 150 | 125 | 277 | 425 | 280 | 400 | | | | 390 | 425 | 425 | 455 | 455 |
| 150-315 | 200 | 150 | 342 | 520 | 350 | 400 | | | | 390 | 425 | 425 | 455 | 455 |
| 150-400 | 200 | 150 | 342 | 520 | 350 | 450 | | | | | 425 | 425 | 455 | 455 |

| | vh | | | | | | | | | | | | | | | | |
|---------|------|---------|---------|----------|----------|----------|----------|----------|----------|----------|----------|----------|----------|----------|----------|----------|----------|
| | F165 | | | F215 | | | F265 | | F300 | | | | F350 | F400 | | F500 | |
| sv max | 262 | 333 | 333 | 365 | 385 | 426 | 426 | 535 | 535 | 627 | 665 | 737 | 790 | 790 | 815 | 833 | 918 |
| CF | 80 | 90 S | 90 L | 100 L | 112 M | 132 S | 132 M | 160 M | 160 L | 180 M | 180 L | 200 L | 225 S | 225 M | 250 M | 280 S | 280 M |
| ...-160 | 350 | 350 | 350 | 350 | 350 | 350 | | 350 | 350 | 350 | | 400 | | | | | |
| ...-200 | 400 | 400 | 400 | 400 | 400 | 400 | 400 | 400 | 400 | 400 | | 400 | | 450 | 550 | 550 | |
| ...-250 | 450 | 450 | 450 | 450 | 450 | 450 | 450 | 450 | 450 | 450 | 450 | 450 | | 450 | 550 | 550 | 550 |
| ...-315 | | | | 550 | 550 | 550 | 550 | 550 | 550 | 550 | 550 | 550 | 550 | 550 | 550 | 550 | 550 |
| ...-400 | | | | | | 620 | 620 | 620 | 620 | 620 | 620 | 620 | 620 | 620 | 620 | 620 | |

8.10 Pump dimensions 200-200 / 250B-315 K2, with suction bend

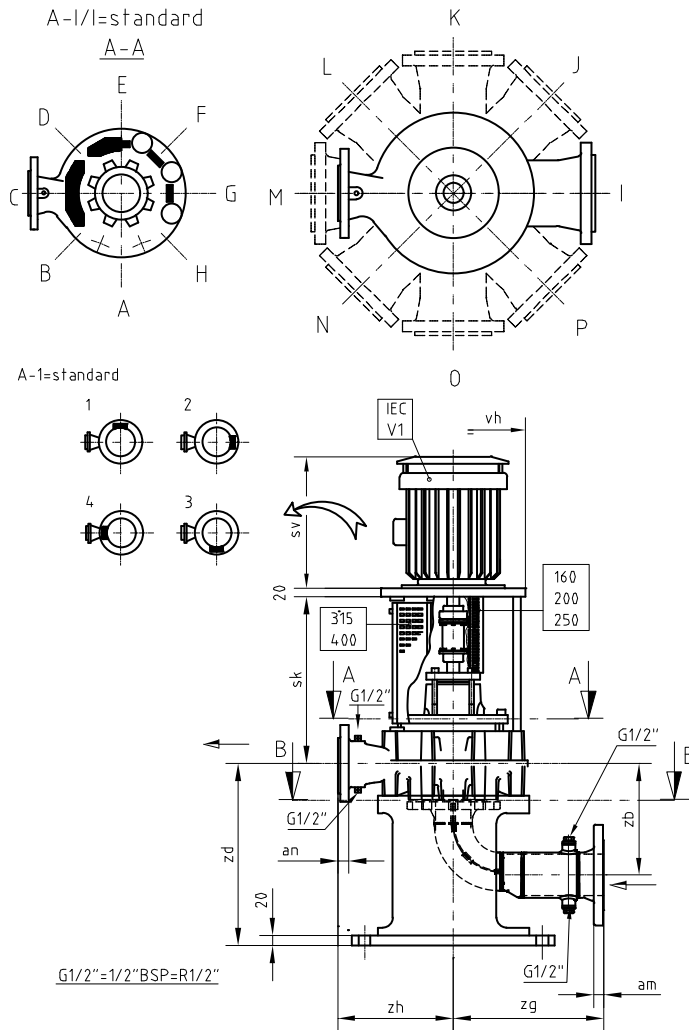

Figure 23: Pump dimensions 200-200 / 250B-315 K2, with suction bend.

Standard:

- suction bend: pos I
- junction box electric motor: pos 1

| | aa | ab | zb | zd | zg | zh | vh | sk | | |
|----------|-----|-----|-----|-----|-----|-----|-----------|--------|----------------------------------|--------------------------------------|
| | | | | | | | | 132S/M | 160L 180S/L 200L 225M02 | 225S/M 250M 280S/M 315S/M02 |
| 200-200 | 200 | 200 | 498 | 700 | 500 | 400 | 18" x 9,5 | 335 | 355 | |
| 250B-315 | 250 | 250 | 533 | 800 | 600 | 500 | 20" x 9,5 | | 420 | 455 |

| | vh | | | | | | | | | | | |
|----------|------|------|------|------|------|------|------|------|------|------|------|------|
| | F265 | | F300 | | | | F350 | F400 | | F500 | | |
| sv max | 426 | 426 | 535 | 535 | 627 | 665 | 737 | 790 | 790 | 815 | 833 | 918 |
| | 132S | 132M | 160M | 160L | 180M | 180L | 200L | 225S | 225M | 250M | 280S | 280M |
| 200-200 | 450 | 450 | 450 | 450 | 450 | 450 | 450 | | 450 | 550 | 550 | 550 |
| 250B-315 | | | 550 | 550 | 550 | 550 | 550 | 550 | 550 | 550 | 550 | 550 |

8.11 Pump dimensions K3, with suction bend

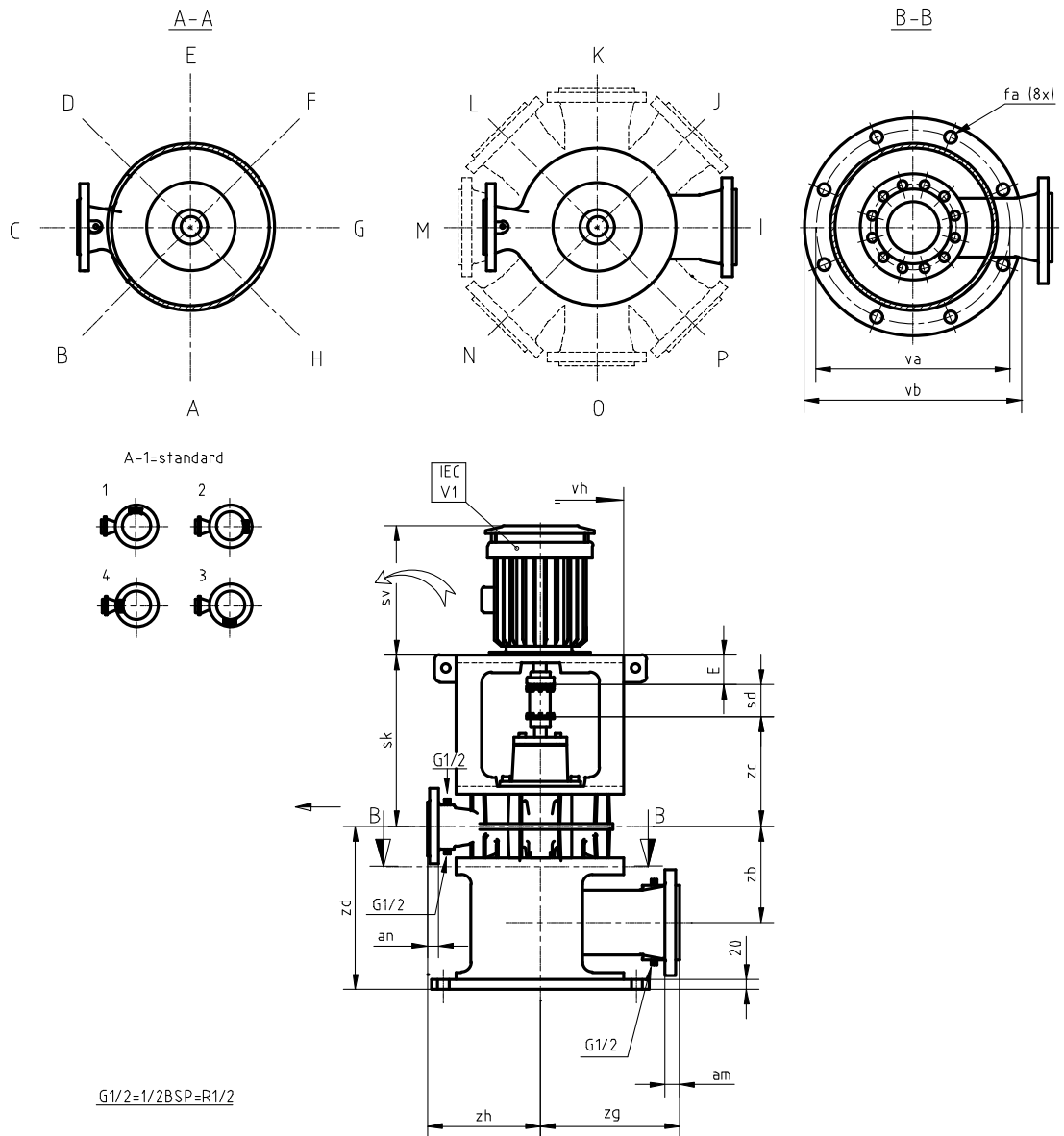

Figure 24: Pump dimensions K3, with suction bend.

Standard:

- disassembly opening lantern: pos A
- suction bend: pos I
- junction box electric motor: pos 1

| | aa | ab | sd | zb | (zc) | zd | zg | zh | va | vb | vh | fa | sk | | | |
|----------|-----|-----|-----|-----|------|-----|-----|-----|-----|------|-----------|--------|---|---|----------------------------------|----------------------------------|
| | | | | | | | | | | | | | 160L 180S/L 200L 225M02 E=110 | 225S/M 250M 280S/M 315S/M2poles E=140 | 315S/L/M 4-6-8 poles E=170 | 355S/L/M 4-6-8 poles E=210 |
| 125-500 | 200 | 125 | 200 | 337 | 460 | 600 | 350 | 500 | 950 | 1000 | 32" x 9,5 | 8 x 22 | 770 | 800 | 830 | 870 |
| 150B-400 | 250 | 150 | 200 | 357 | 470 | 700 | 600 | 500 | 850 | 900 | 28" x 9,5 | 8 x 22 | 780 | 810 | 840 | |
| 150-500 | 250 | 150 | 200 | 357 | 465 | 700 | 600 | 550 | 950 | 1000 | 32" x 9,5 | 8 x 22 | 775 | 805 | 835 | 875 |
| 200-250 | 200 | 200 | 200 | 342 | 475 | 750 | 350 | 425 | 750 | 800 | 26" x 9,5 | 8 x 22 | 785 | 815 | | |
| 200-315 | 250 | 200 | 200 | 357 | 475 | 750 | 600 | 450 | 750 | 800 | 26" x 9,5 | 8 x 22 | 785 | 815 | 845 | |
| 200-400 | 300 | 200 | 250 | 397 | 475 | 750 | 700 | 550 | 850 | 900 | 28" x 9,5 | 8 x 22 | 835 | 865 | 895 | |
| 250-250 | 300 | 250 | 250 | 452 | 495 | 800 | 700 | 550 | 750 | 800 | 26" x 9,5 | 8 x 22 | 855 | 885 | 915 | |
| 250-315 | 300 | 250 | 250 | 437 | 480 | 750 | 700 | 500 | 750 | 800 | 26" x 9,5 | 8 x 22 | 840 | 870 | 900 | |
| 300-250 | 300 | 300 | 250 | 387 | 500 | 750 | 700 | 550 | 750 | 800 | 26" x 9,5 | 8 x 22 | 860 | 890 | 920 | |
| 300-315 | 300 | 300 | 250 | 387 | 500 | 750 | 700 | 550 | 750 | 800 | 26" x 9,5 | 8 x 22 | | 890 | 920 | |

| | F165 | | | F215 | | F265 | | F300 | | | | F350 | F400 | | F500 | | | F600 | | | | F740 | |
|--------|------|---------|---------|----------|----------|----------|----------|----------|----------|----------|----------|----------|----------|----------|----------|----------|----------|-------------|-------------|----------|----------|----------|----------|
| sv max | 262 | 333 | 333 | 365 | 385 | 426 | 426 | 535 | 535 | 627 | 665 | 737 | 790 | 790 | 815 | 833 | 918 | 1155 | 1155 | 1155 | 1225 | 1320 | 1410 |
| | 80 | 90 S | 90 L | 100 L | 112 M | 132 S | 132 M | 160 M | 160 L | 180 M | 180 L | 200 L | 225 S | 225 M | 250 M | 280 S | 280 M | 315 S-02 | 315 M-02 | 315 S | 315 M | 355 S | 355 M |

8.12 Pump dimensions K4, with suction bend

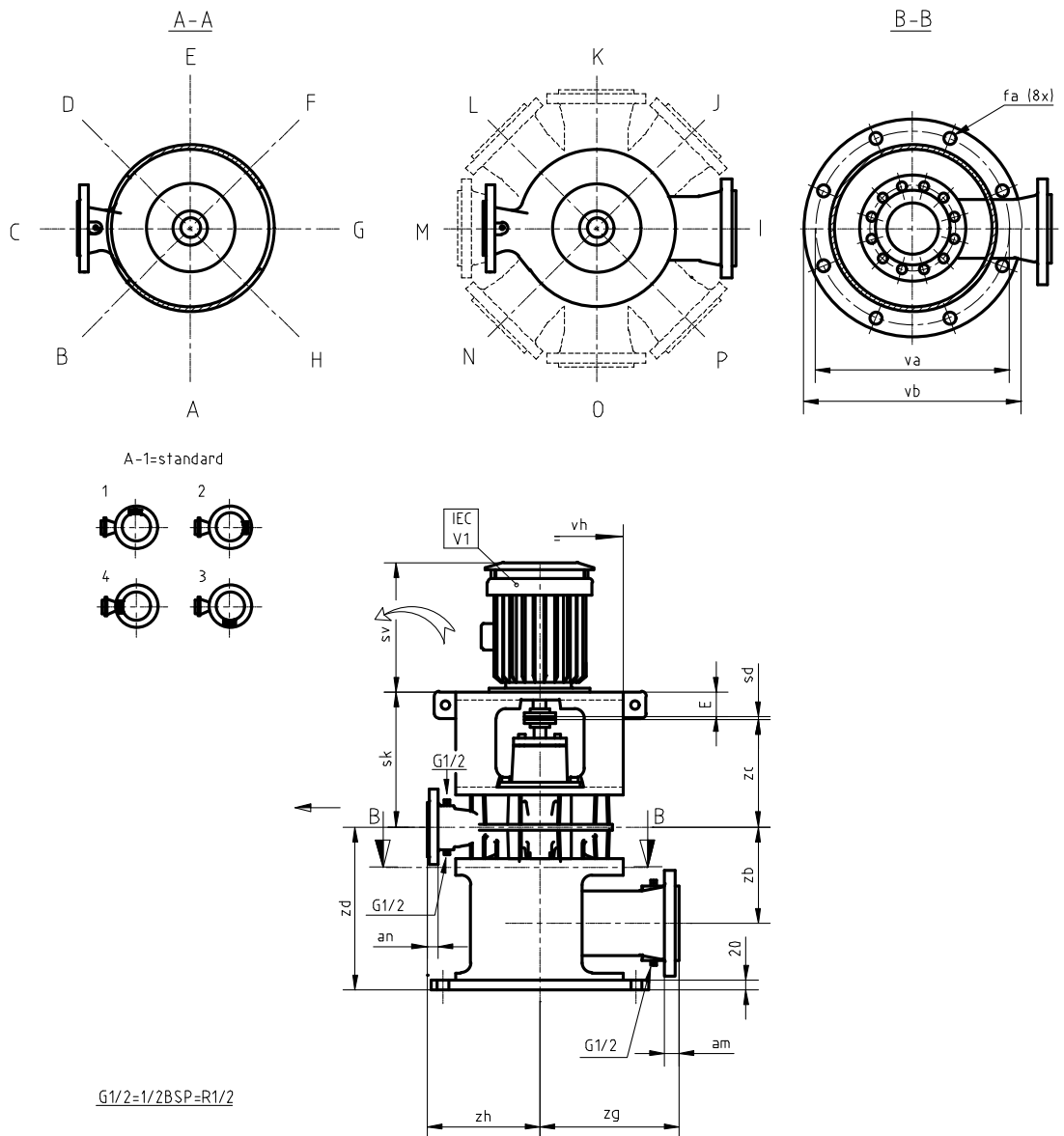

Figure 25: Pump dimensions K4, with suction bend.

Standard:

- disassembly opening lantern: pos A
- suction bend: pos I
- junction box electric motor: pos 1

| | aa | ab | sd | zb | (zc) | zd | zg | zh | va | vb | vh | fa | sk | | | |
|----------|-----|-----|-----|-----|------|-----|-----|-----|-----|------|-----------|--------|---|---|----------------------------------|----------------------------------|
| | | | | | | | | | | | | | 160L 180S/L 200L 225M02 E=110 | 225S/M 250M 280S/M 315S/M2poles E=140 | 315S/L/M 4-6-8 poles E=170 | 355S/L/M 4-6-8 poles E=210 |
| 125-500 | 200 | 125 | 200 | 337 | 460 | 600 | 350 | 500 | 950 | 1000 | 32" x 9,5 | 8 x 22 | 575 | 605 | 635 | 675 |
| 150B-400 | 250 | 150 | 200 | 357 | 470 | 700 | 600 | 500 | 850 | 900 | 28" x 9,5 | 8 x 22 | 585 | 615 | 645 | |
| 150-500 | 250 | 150 | 200 | 357 | 465 | 700 | 600 | 550 | 950 | 1000 | 32" x 9,5 | 8 x 22 | 580 | 610 | 640 | 680 |
| 200-250 | 200 | 200 | 200 | 342 | 475 | 750 | 350 | 425 | 750 | 800 | 26" x 9,5 | 8 x 22 | 590 | 620 | | |
| 200-315 | 250 | 200 | 200 | 357 | 475 | 750 | 600 | 450 | 750 | 800 | 26" x 9,5 | 8 x 22 | 590 | 620 | 650 | |
| 200-400 | 300 | 200 | 250 | 397 | 475 | 750 | 700 | 550 | 850 | 900 | 28" x 9,5 | 8 x 22 | 590 | 620 | 650 | |
| 250-250 | 300 | 250 | 250 | 452 | 495 | 800 | 700 | 550 | 750 | 800 | 26" x 9,5 | 8 x 22 | 610 | 640 | 670 | |
| 250-315 | 300 | 250 | 250 | 437 | 480 | 750 | 700 | 500 | 750 | 800 | 26" x 9,5 | 8 x 22 | 595 | 625 | 655 | |
| 300-250 | 300 | 300 | 250 | 387 | 500 | 750 | 700 | 550 | 750 | 800 | 26" x 9,5 | 8 x 22 | 615 | 645 | 675 | |
| 300-315 | 300 | 300 | 250 | 387 | 500 | 750 | 700 | 550 | 750 | 800 | 26" x 9,5 | 8 x 22 | | 645 | 675 | |

| | F165 | | | F215 | | F265 | | F300 | | | | F350 | F400 | | F500 | | | F600 | | | | F740 | |
|--------|------|---------|---------|----------|----------|----------|----------|----------|----------|----------|----------|----------|----------|----------|----------|----------|----------|-------------|-------------|----------|----------|----------|----------|
| sv max | 262 | 333 | 333 | 365 | 385 | 426 | 426 | 535 | 535 | 627 | 665 | 737 | 790 | 790 | 815 | 833 | 918 | 1155 | 1155 | 1155 | 1225 | 1320 | 1410 |
| | 80 | 90 S | 90 L | 100 L | 112 M | 132 S | 132 M | 160 M | 160 L | 180 M | 180 L | 200 L | 225 S | 225 M | 250 M | 280 S | 280 M | 315 S-02 | 315 M-02 | 315 S | 315 M | 355 S | 355 M |

9 Parts

9.1 Ordering parts

9.1.1 Order form

You can use the order form included in this manual for ordering parts.

When ordering parts always quote the following data:

- 1 Your **address**.
- 2 The **quantity, the item number and the description** of the part.
- 3 The **pump number**. The pump number is stated on the label on the cover of this manual and on the type plate of the pump.
- 4 In the event of different electric motor voltage you should state the correct voltage.

9.1.2 Recommended spare parts

Parts marked with a * are recommended spare parts.

9.2 Pump construction K1

9.2.1 Sectional drawing ..-160/..-200/..-250

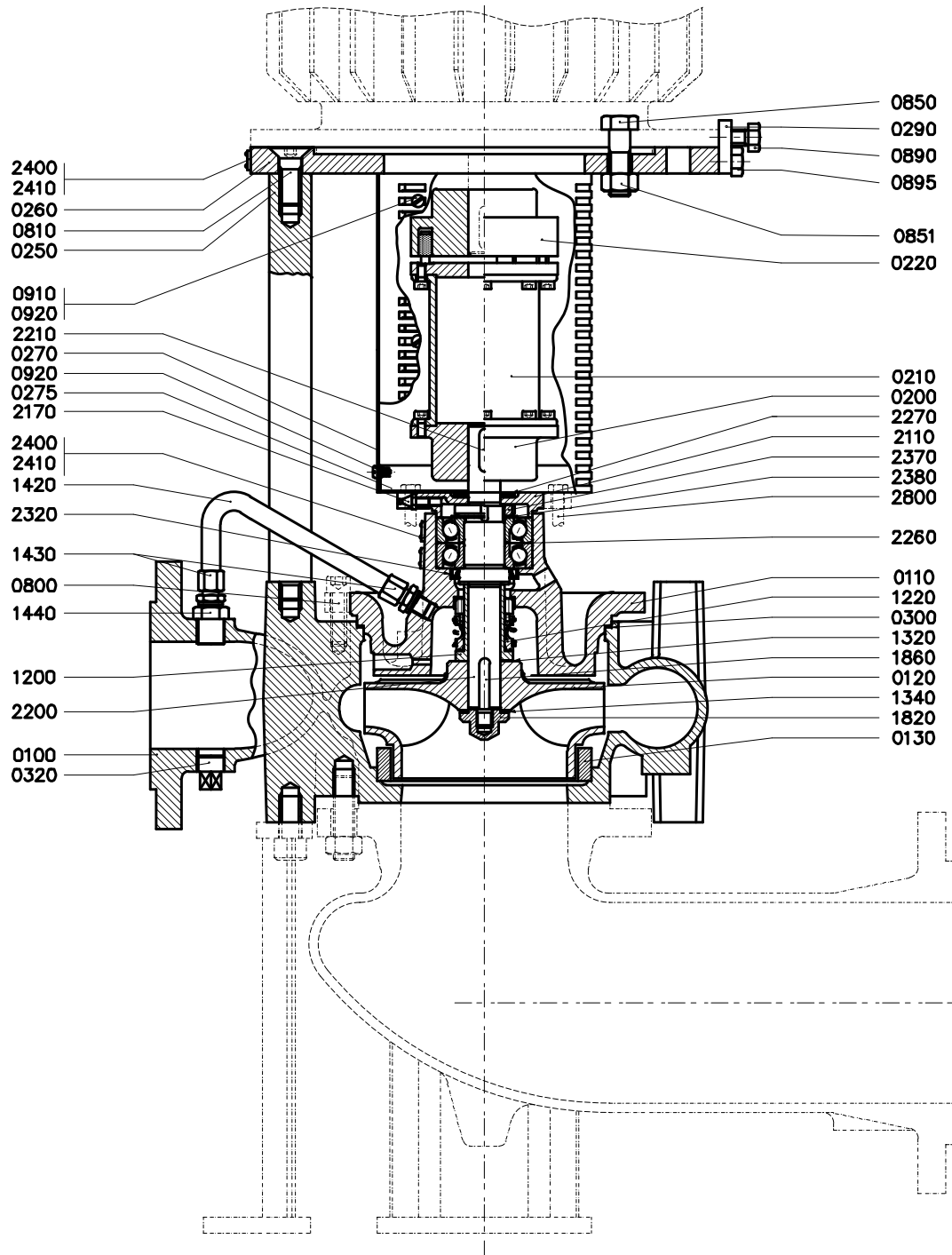

Figure 26: Sectional drawing ..-160/..-200/..-250.

9.2.2 Parts list ...-160/...-200/...-250

See figure 26.

| Item | Quantity | Description | Materials | | | | |
|-------|---------------------|------------------------------|-----------------|--------|---------|-----------------|---------|
| | | | G1 | G2 | G3 | B2 | B3 |
| 0100 | 1 | pump casing | cast iron | | | bronze | |
| 0110 | 1 | pump cover | cast iron | | | bronze | |
| 0120* | 1 | impeller | cast iron | bronze | alu.brz | bronze | alu.brz |
| 0130* | 1 | wear ring | cast iron | bronze | | | |
| 0200 | 1 | coupling half, pump side | cast iron | | | | |
| 0210 | 1 | spacer | cast iron | | | | |
| 0220 | 1 | coupling half, motor side | cast iron | | | | |
| 0250 | 6 | rod | steel | | | | |
| 0260 | 1 | flange | steel | | | | |
| 0270 | 1 | guard | aluminium | | | | |
| 0275 | 1 | assembly plate | aluminium | | | | |
| 0290 | 4 | adjusting cam | stainless steel | | | | |
| 0300* | 1 | gasket | -- | | | | |
| 0320 | 1 | plug | cast iron | | | bronze | |
| 0800 | 8/12 ^(*) | Allen screw | steel | | | stainless steel | |
| 0810 | 6 | countersunk screw | steel | | | | |
| 0850 | 4/8 ^(*) | bolt | steel | | | | |
| 0851 | 4/8 ^(*) | nut | steel | | | | |
| 0890 | 4 | bolt | stainless steel | | | | |
| 0895 | 8 | bolt | steel | | | | |
| 0910 | 4 | speed nut | spring steel | | | | |
| 0920 | 12 | tapping screw | stainless steel | | | | |
| 1200* | 1 | shaft sleeve | bronze | | | | |
| 1220* | 1 | mechanical seal | -- | | | | |
| 1320* | 1 | gasket | -- | | | | |
| 1340* | 1 | gasket | -- | | | | |
| 1420 | 1 | pipe | stainless steel | | | | |
| 1430 | 2 | male connector | brass | | | | |
| 1440 | 1 | extension piece | stainless steel | | | | |
| 1820* | 1 | cap nut | stainless steel | | | | |
| 1860* | 1 | key | stainless steel | | | | |
| 2110 | 1 | bearing cover | cast iron | | | | |
| 2170 | 1 | grease nipple | steel | | | | |
| 2200* | 1 | pump shaft | stainless steel | | | | |
| 2210* | 1 | key | steel | | | | |
| 2260* | 2 | angular contact ball bearing | -- | | | | |
| 2270 | 1 | deflector | rubber | | | | |
| 2320* | 1 | oil seal | rubber | | | | |
| 2370 | 1 | lock nut | steel | | | | |
| 2380* | 1 | locking washer | steel | | | | |
| 2400 | 1 | name plate | stainless steel | | | | |
| 2410 | 1 | arrow plate | aluminium | | | | |
| 2800 | 4 | hexagon head screw | steel | | | | |

alu.brz = aluminium bronze ^(*) Quantity depends on pump type

9.2.3 Sectional drawing ..-315/..-400

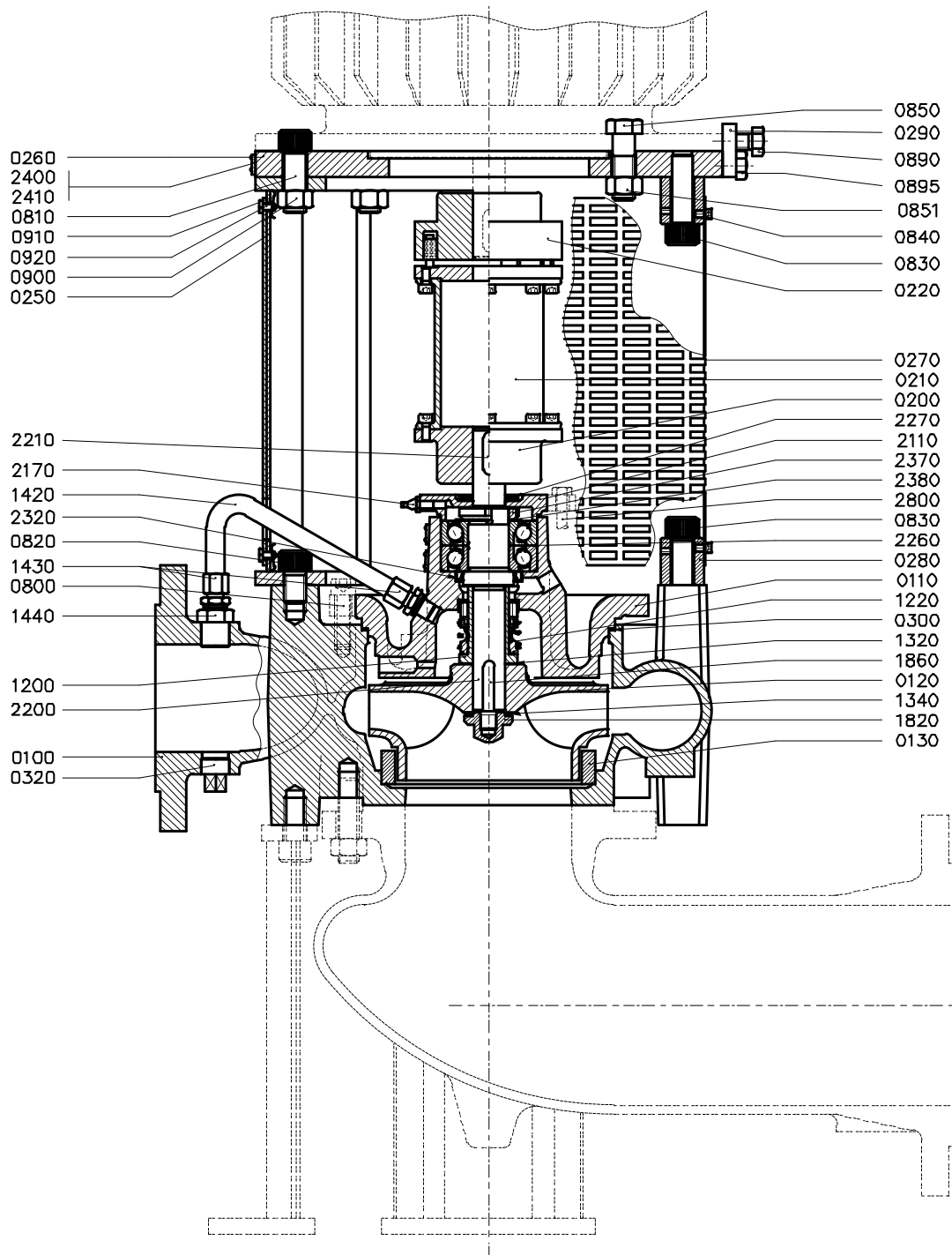

Figure 27: Sectional drawing ..-315/..-400.

9.2.4 Parts list ...-315/...-400

See figure 27.

| Item | Quantity | Description | Materials | | | | |
|-------|---------------------|------------------------------|-----------------|--------|---------|-----------------|---------|
| | | | G1 | G2 | G3 | B2 | B3 |
| 0100 | 1 | pump casing | cast iron | | | bronze | |
| 0110 | 1 | pump cover | cast iron | | | bronze | |
| 0120* | 1 | impeller | cast iron | bronze | alu.brz | bronze | alu.brz |
| 0130* | 1 | wear ring | cast iron | bronze | | | |
| 0200 | 1 | coupling half, pump side | cast iron | | | | |
| 0210 | 1 | spacer | cast iron | | | | |
| 0220 | 1 | coupling half, motor side | cast iron | | | | |
| 0250 | 3 | lantern element | steel | | | | |
| 0260 | 1 | flange | steel | | | | |
| 0270 | 5 | guard | steel | | | | |
| 0280 | 4 | assembling bush | steel | | | | |
| 0290 | 4 | adjusting cam | stainless steel | | | | |
| 0300* | 1 | gasket | -- | | | | |
| 0320 | 1 | plug | cast iron | | | bronze | |
| 0800 | 8/12 ^(*) | Allen screw | steel | | | stainless steel | |
| 0810 | 6 | Allen screw | steel | | | | |
| 0820 | 6 | Allen screw | steel | | | | |
| 0830 | 4 | Allen screw | steel | | | | |
| 0840 | 4 | Allen screw | brass | | | | |
| 0850 | 4/8 ^(*) | bolt | steel | | | | |
| 0851 | 4/8 ^(*) | nut | steel | | | | |
| 0890 | 4 | bolt | steel | | | | |
| 0895 | 8 | bolt | stainless steel | | | | |
| 0900 | 6 | nut | steel | | | | |
| 0910 | 12 | speed nut | spring steel | | | | |
| 0920 | 12 | tapping screw | stainless steel | | | | |
| 1200* | 1 | shaft sleeve | bronze | | | | |
| 1220* | 1 | mechanical seal | -- | | | | |
| 1320* | 1 | gasket | -- | | | | |
| 1340* | 1 | gasket | -- | | | | |
| 1420 | 1 | pipe | stainless steel | | | | |
| 1430 | 2 | male connector | brass | | | | |
| 1440 | 1 | extension piece | stainless steel | | | | |
| 1820* | 1 | cap nut | stainless steel | | | | |
| 1860* | 1 | key | stainless steel | | | | |
| 2110 | 1 | bearing cover | cast iron | | | | |
| 2170 | 1 | grease nipple | steel | | | | |
| 2200* | 1 | pump shaft | stainless steel | | | | |
| 2210* | 1 | key | steel | | | | |
| 2260* | 2 | angular contact ball bearing | -- | | | | |
| 2270 | 1 | deflector | rubber | | | | |
| 2320* | 1 | oil seal | rubber | | | | |
| 2370 | 1 | lock nut | steel | | | | |
| 2380* | 1 | locking washer | steel | | | | |

› Johnson Pump®

| Item | Quantity | Description | Materials | | | | |
|------|----------|--------------------|-----------------|----|----|----|----|
| | | | G1 | G2 | G3 | B2 | B3 |
| 2400 | 1 | name plate | stainless steel | | | | |
| 2410 | 1 | arrow plate | aluminium | | | | |
| 2800 | 4 | hexagon head screw | steel | | | | |

alu.brz = aluminium bronze

(*) Quantity depends on pump type

9.3 Pump construction K2

9.3.1 Sectional drawing

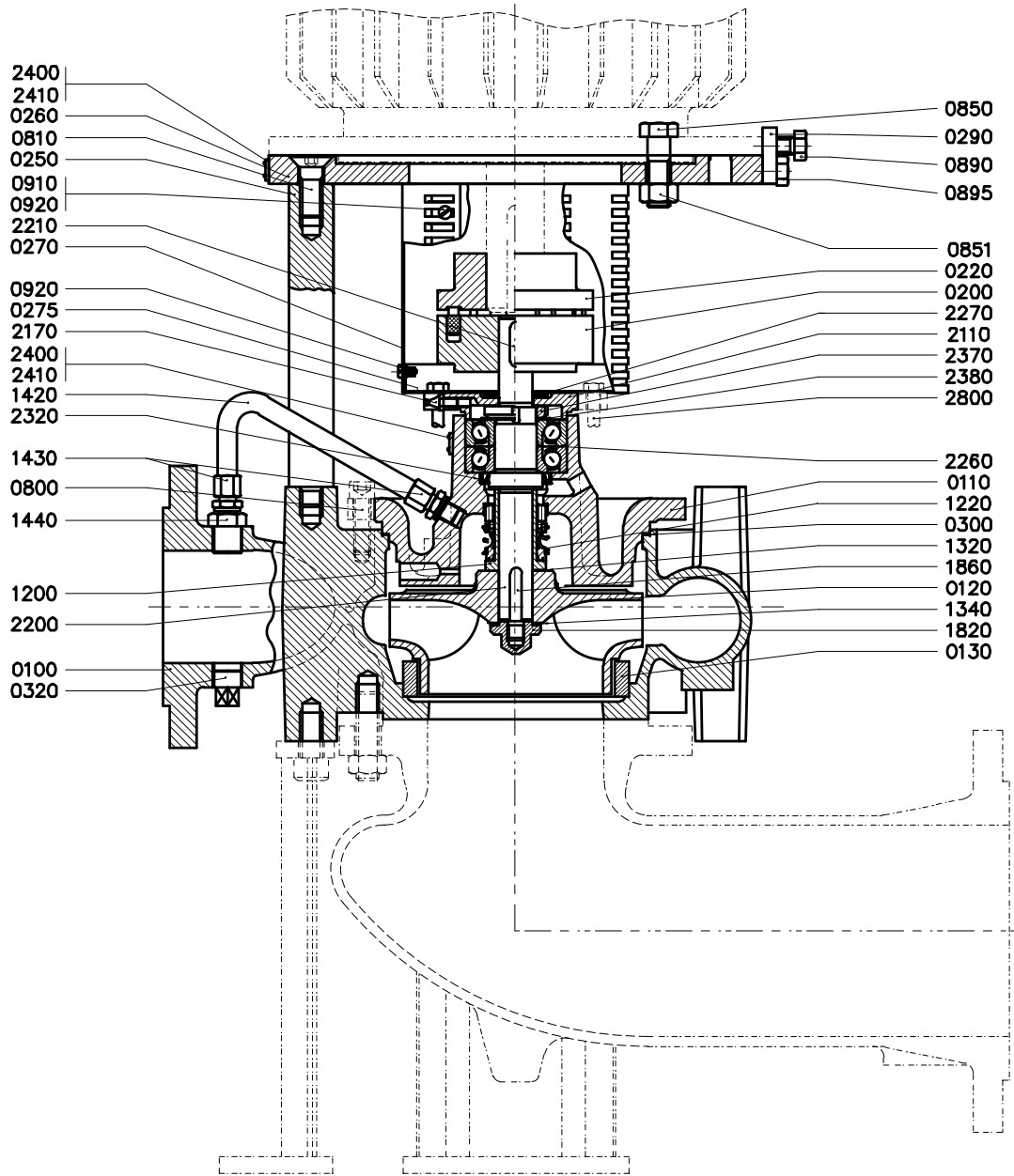

Figure 28: Sectional drawing.

9.3.2 Parts list

See figure 28.

| Item | Quantity | Description | Materials | | | | |
|-------|---------------------|------------------------------|-----------------|--------|---------|-----------------|---------|
| | | | G1 | G2 | G3 | B2 | B3 |
| 0100 | 1 | pump casing | cast iron | | | bronze | |
| 0110 | 1 | pump cover | cast iron | | | bronze | |
| 0120* | 1 | impeller | cast iron | bronze | alu.brz | bronze | alu.brz |
| 0130* | 1 | wear ring | cast iron | bronze | | | |
| 0200 | 1 | coupling half, pump side | cast iron | | | | |
| 0220 | 1 | coupling half, motor side | cast iron | | | | |
| 0250 | 8 | rod | steel | | | | |
| 0260 | 1 | flange | steel | | | | |
| 0270 | 1 | guard | aluminium | | | | |
| 0275 | 1 | assembly plate | aluminium | | | | |
| 0290 | 4 | adjusting cam | stainless steel | | | | |
| 0300* | 1 | gasket | -- | | | | |
| 0320 | 1 | plug | cast iron | | | bronze | |
| 0800 | 8/12 ^(*) | Allen screw | steel | | | stainless steel | |
| 0810 | 8 | countersunk screw | steel | | | | |
| 0850 | 4/8 ^(*) | bolt | steel | | | | |
| 0851 | 4/8 ^(*) | nut | steel | | | | |
| 0890 | 4 | bolt | stainless steel | | | | |
| 0895 | 8 | bolt | steel | | | | |
| 0910 | 2 | speed nut | spring steel | | | | |
| 0920 | 10 | tapping screw | stainless steel | | | | |
| 1200* | 1 | shaft sleeve | bronze | | | | |
| 1220* | 1 | mechanical seal | -- | | | | |
| 1320* | 1 | gasket | -- | | | | |
| 1340* | 1 | gasket | -- | | | | |
| 1420 | 1 | pipe | stainless steel | | | | |
| 1430 | 2 | male connector | brass | | | | |
| 1440 | 1 | extension piece | stainless steel | | | | |
| 1820* | 1 | cap nut | stainless steel | | | | |
| 1860* | 1 | key | stainless steel | | | | |
| 2110 | 1 | bearing cover | cast iron | | | | |
| 2170 | 1 | grease nipple | steel | | | | |
| 2200* | 1 | pump shaft | stainless steel | | | | |
| 2210* | 1 | key | steel | | | | |
| 2260* | 2 | angular contact ball bearing | -- | | | | |
| 2270 | 1 | deflector | rubber | | | | |
| 2320* | 1 | oil seal | rubber | | | | |
| 2370 | 1 | lock nut | steel | | | | |
| 2380* | 1 | locking washer | steel | | | | |
| 2400 | 1 | name plate | stainless steel | | | | |
| 2410 | 1 | arrow plate | aluminium | | | | |
| 2800 | 4 | hexagon head screw | steel | | | | |

alu.brz = aluminium bronze (*) Quantity depends on pump type

9.4 Pump construction K3

9.4.1 Sectional drawing 200-400, 250-250, 250-315, 300-250, 300-315

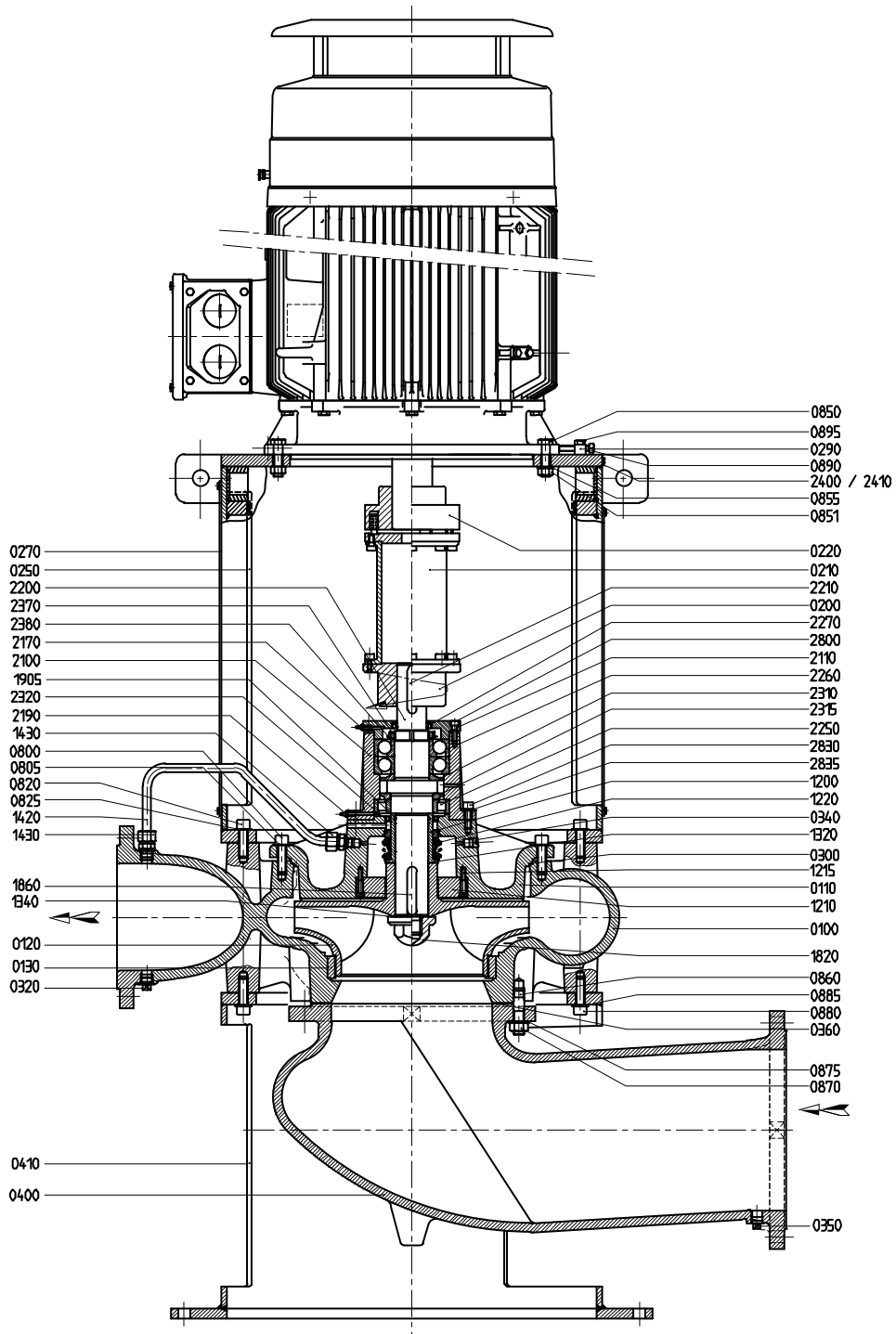

Figure 29: Sectional drawing 200-400, 250-250, 250-315, 300-250, 300-315.

9.4.2 Parts list 200-400, 250-250, 250-315, 300-250, 300-315

See figure 29.

| Item | Quantity | Description | Materials | | | | |
|-------|----------------------|---------------------------|-----------------|--------|---------|--------|---------|
| | | | G1 | G2 | G3 | B2 | B3 |
| 0100 | 1 | pump casing | cast iron | | | bronze | |
| 0110 | 1 | pump cover | cast iron | | | bronze | |
| 0120* | 1 | impeller | cast iron | bronze | alu.brz | bronze | alu.brz |
| 0130* | 1 | wear ring | cast iron | bronze | | | |
| 0200 | 1 | coupling half, pump side | cast iron | | | | |
| 0210 | 1 | spacer | cast iron | | | | |
| 0220 | 1 | coupling half, motor side | cast iron | | | | |
| 0250 | 1 | lantern piece | steel | | | | |
| 0270 | 2 | guard | stainless steel | | | | |
| 0290 | 4 | adjusting cam | stainless steel | | | | |
| 0300* | 1 | gasket | -- | | | | |
| 0320 | 1 | plug | stainless steel | | | | |
| 0340 | 1 | plug | stainless steel | | | | |
| 0350 | 1 | plug | stainless steel | | | | |
| 0360 | 1 | gasket | -- | | | | |
| 0400 | 1 | suction bend | cast iron | | | | bronze |
| 0410 | 1 | support | steel | | | | |
| 0800 | 12/16 ^(*) | Allen screw | stainless steel | | | | |
| 0805 | 12/16 ^(*) | washer | stainless steel | | | | |
| 0820 | 8 | Allen screw | stainless steel | | | | |
| 0825 | 8 | washer | stainless steel | | | | |
| 0850 | 4/8 ^(*) | bolt | stainless steel | | | | |
| 0851 | 4/8 ^(*) | nut | stainless steel | | | | |
| 0855 | 4/8 ^(*) | washer | stainless steel | | | | |
| 0860 | 12/16 ^(*) | stud | stainless steel | | | | |
| 0870 | 12/16 ^(*) | nut | stainless steel | | | | |
| 0875 | 12/16 ^(*) | washer | stainless steel | | | | |
| 0880 | 8 | Allen screw | stainless steel | | | | |
| 0885 | 8 | washer | stainless steel | | | | |
| 0890 | 4 | bolt | stainless steel | | | | |
| 0895 | 4/8 ^(*) | bolt | stainless steel | | | | |
| 1200* | 1 | shaft sleeve | bronze | | | | |
| 1210 | 1 | throttling bush | bronze | | | | |
| 1215 | 3 | Allen screw | stainless steel | | | | |
| 1220* | 1 | mechanical seal | -- | | | | |
| 1320* | 1 | gasket | -- | | | | |
| 1340* | 1 | gasket | -- | | | | |
| 1420 | 1 | pipe | stainless steel | | | | |
| 1430 | 2 | male connector | stainless steel | | | | |
| 1820* | 1 | cap nut | stainless steel | | | | |
| 1860* | 1 | key | stainless steel | | | | |
| 1905* | 1 | O-ring | AR/NBR | | | | |
| 2100 | 1 | bearing bracket | cast iron | | | | |

| Item | Quantity | Description | Materials | | | | |
|-------|----------|------------------------------|-----------------|----|----|----|----|
| | | | G1 | G2 | G3 | B2 | B3 |
| 2110 | 1 | bearing cover | cast iron | | | | |
| 2170 | 1 | grease nipple | steel | | | | |
| 2190 | 1 | grease nipple | steel | | | | |
| 2200* | 1 | pump shaft | stainless steel | | | | |
| 2210* | 1 | key | steel | | | | |
| 2250* | 1 | cylindrical roller bearing | -- | | | | |
| 2260* | 2 | angular contact ball bearing | -- | | | | |
| 2270* | 1 | oil seal | rubber | | | | |
| 2310 | 1 | grease control disk | stainless steel | | | | |
| 2315 | 1 | grease control disk | stainless steel | | | | |
| 2320* | 1 | oil seal | rubber | | | | |
| 2370 | 1 | lock nut | steel | | | | |
| 2380* | 1 | locking washer | steel | | | | |
| 2400 | 1 | name plate | stainless steel | | | | |
| 2410 | 1 | arrow plate | aluminium | | | | |
| 2800 | 4 | Allen screw | stainless steel | | | | |
| 2830 | 6 | Allen screw | stainless steel | | | | |
| 2835 | 6 | washer | stainless steel | | | | |

alu.brz = aluminium bronze

(*) Quantity depends on pump type

9.4.3 Sectional drawing 150B-400, 150-500, 200-250, 200-315

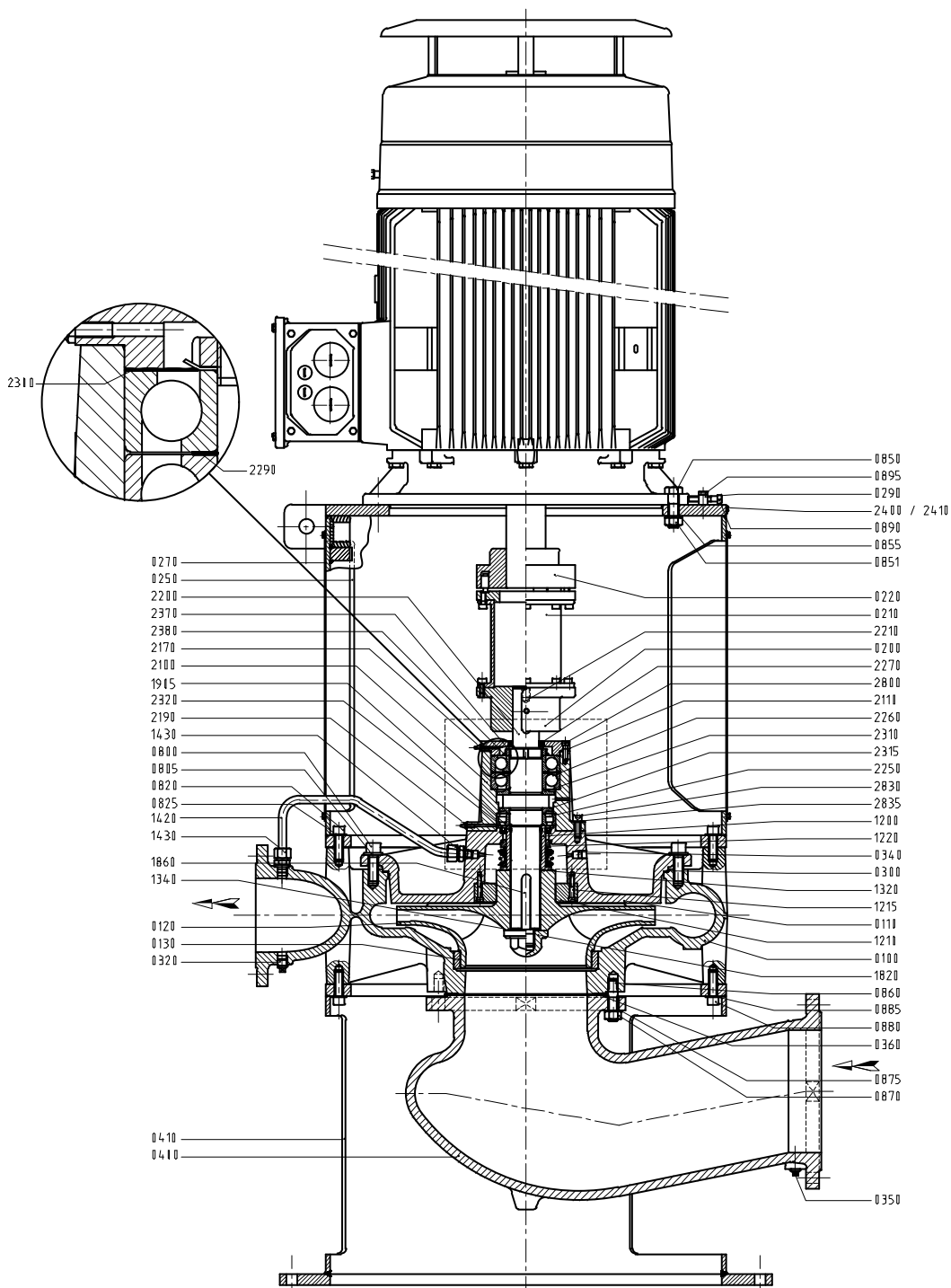

Figure 30: Sectional drawing 150B-400, 150-500, 200-250, 200-315.

9.4.4 Parts list 150B-400, 150-500, 200-250, 200-315

See figure 30.

| Item | Quantity | Description | Materials | | | | |
|-------|----------------------|---------------------------|-----------------|--------|---------|--------|---------|
| | | | G1 | G2 | G3 | B2 | B3 |
| 0100 | 1 | pump casing | cast iron | | | bronze | |
| 0110 | 1 | pump cover | cast iron | | | bronze | |
| 0120* | 1 | impeller | cast iron | bronze | alu.brz | bronze | alu.brz |
| 0130* | 1 | wear ring | cast iron | bronze | | | |
| 0200 | 1 | coupling half, pump side | cast iron | | | | |
| 0210 | 1 | spacer | cast iron | | | | |
| 0220 | 1 | coupling half, motor side | cast iron | | | | |
| 0250 | 1 | lantern piece | steel | | | | |
| 0270 | 2 | guard | stainless steel | | | | |
| 0290 | 4 | adjusting cam | stainless steel | | | | |
| 0300* | 1 | gasket | -- | | | | |
| 0320 | 1 | plug | stainless steel | | | | |
| 0340 | 1 | plug | stainless steel | | | | |
| 0350 | 1 | plug | stainless steel | | | | |
| 0360 | 1 | gasket | -- | | | | |
| 0400 | 1 | suction bend | cast iron | | | | bronze |
| 0410 | 1 | support | steel | | | | |
| 0800 | 12/16 ^(*) | Allen screw | stainless steel | | | | |
| 0805 | 12/16 ^(*) | washer | stainless steel | | | | |
| 0820 | 8 | Allen screw | stainless steel | | | | |
| 0825 | 8 | washer | stainless steel | | | | |
| 0850 | 4/8 ^(*) | bolt | stainless steel | | | | |
| 0851 | 4/8 ^(*) | nut | stainless steel | | | | |
| 0855 | 4/8 ^(*) | washer | stainless steel | | | | |
| 0860 | 12/16 ^(*) | stud | stainless steel | | | | |
| 0870 | 12/16 ^(*) | nut | stainless steel | | | | |
| 0875 | 12/16 ^(*) | washer | stainless steel | | | | |
| 0880 | 8 | Allen screw | stainless steel | | | | |
| 0885 | 8 | washer | stainless steel | | | | |
| 0890 | 4 | bolt | stainless steel | | | | |
| 0895 | 4/8 ^(*) | bolt | stainless steel | | | | |
| 1200* | 1 | shaft sleeve | bronze | | | | |
| 1210 | 1 | throttling bush | bronze | | | | |
| 1215 | 3 | Allen screw | stainless steel | | | | |
| 1220* | 1 | mechanical seal | -- | | | | |
| 1320* | 1 | gasket | -- | | | | |
| 1340* | 1 | gasket | -- | | | | |
| 1420 | 1 | pipe | stainless steel | | | | |
| 1430 | 2 | male connector | stainless steel | | | | |
| 1820* | 1 | cap nut | stainless steel | | | | |
| 1860* | 1/2 ^(*) | key | stainless steel | | | | |
| 1905* | 1 | O-ring | AR/NBR | | | | |
| 2100 | 1 | bearing bracket | cast iron | | | | |

| Item | Quantity | Description | Materials | | | | |
|-------|----------|------------------------------|-----------------|----|----|----|----|
| | | | G1 | G2 | G3 | B2 | B3 |
| 2110 | 1 | bearing cover | cast iron | | | | |
| 2170 | 1 | grease nipple | steel | | | | |
| 2190 | 1 | grease nipple | steel | | | | |
| 2200* | 1 | pump shaft | stainless steel | | | | |
| 2210* | 1 | key | steel | | | | |
| 2250* | 1 | cylindrical roller bearing | -- | | | | |
| 2260* | 2 | angular contact ball bearing | -- | | | | |
| 2270* | 1 | oil seal | rubber | | | | |
| 2290* | 1 | adjusting ring | steel | | | | |
| 2300* | 1 | wave washer | steel | | | | |
| 2310 | 1 | grease control disk | stainless steel | | | | |
| 2315 | 1 | grease control disk | stainless steel | | | | |
| 2320* | 1 | oil seal | rubber | | | | |
| 2370 | 1 | lock nut | steel | | | | |
| 2380* | 1 | locking washer | steel | | | | |
| 2400 | 1 | name plate | stainless steel | | | | |
| 2410 | 1 | arrow plate | aluminium | | | | |
| 2800 | 4 | Allen screw | stainless steel | | | | |
| 2830 | 6 | Allen screw | stainless steel | | | | |
| 2835 | 6 | washer | stainless steel | | | | |

alu.brz = aluminium bronze

(*) Quantity depends on pump type

9.4.5 Sectional drawing 125-500

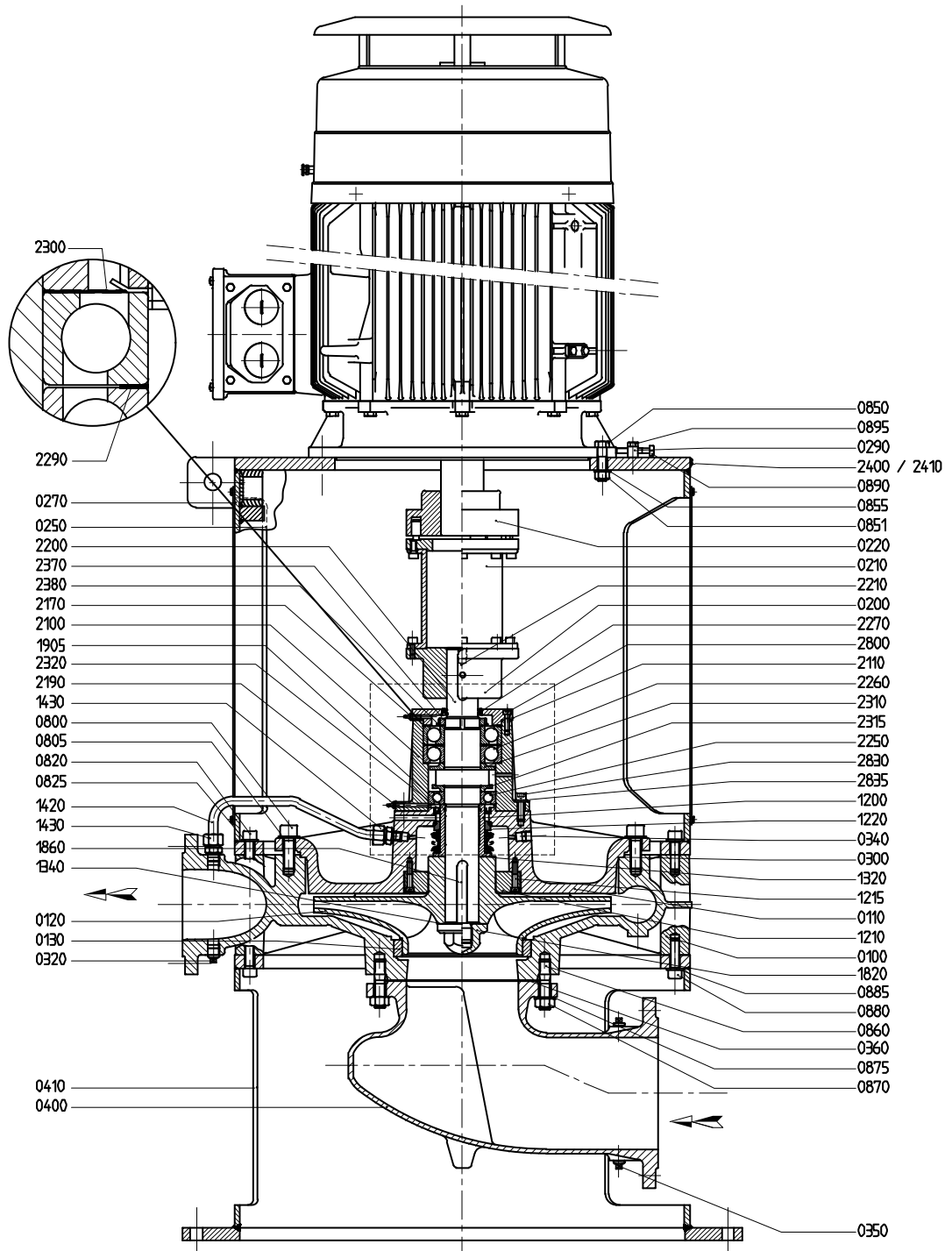

Figure 31: Sectional drawing 125-500.

9.4.6 Parts list 125-500

See figure 31.

| Item | Quantity | Description | Materials | | | | |
|-------|----------------------|---------------------------|-----------------|--------|---------|--------|---------|
| | | | G1 | G2 | G3 | B2 | B3 |
| 0100 | 1 | pump casing | cast iron | | | bronze | |
| 0110 | 1 | pump cover | cast iron | | | bronze | |
| 0120* | 1 | impeller | cast iron | bronze | alu.brz | bronze | alu.brz |
| 0130* | 1 | wear ring | cast iron | bronze | | | |
| 0200 | 1 | coupling half, pump side | cast iron | | | | |
| 0210 | 1 | spacer | cast iron | | | | |
| 0220 | 1 | coupling half, motor side | cast iron | | | | |
| 0250 | 1 | lantern piece | steel | | | | |
| 0270 | 2 | guard | stainless steel | | | | |
| 0290 | 4 | adjusting cam | stainless steel | | | | |
| 0300* | 1 | gasket | -- | | | | |
| 0320 | 1 | plug | stainless steel | | | | |
| 0340 | 1 | plug | stainless steel | | | | |
| 0350 | 1 | plug | stainless steel | | | | |
| 0360 | 1 | gasket | -- | | | | |
| 0400 | 1 | suction bend | cast iron | | | | bronze |
| 0410 | 1 | support | steel | | | | |
| 0800 | 12/16 ^(*) | Allen screw | stainless steel | | | | |
| 0805 | 12/16 ^(*) | washer | stainless steel | | | | |
| 0820 | 8 | Allen screw | stainless steel | | | | |
| 0825 | 8 | washer | stainless steel | | | | |
| 0850 | 4/8 ^(*) | bolt | stainless steel | | | | |
| 0851 | 4/8 ^(*) | nut | stainless steel | | | | |
| 0855 | 4/8 ^(*) | washer | stainless steel | | | | |
| 0860 | 12/16 ^(*) | stud | stainless steel | | | | |
| 0870 | 12/16 ^(*) | nut | stainless steel | | | | |
| 0875 | 12/16 ^(*) | washer | stainless steel | | | | |
| 0880 | 8 | Allen screw | stainless steel | | | | |
| 0885 | 8 | washer | stainless steel | | | | |
| 0890 | 4 | bolt | stainless steel | | | | |
| 0895 | 4/8 ^(*) | bolt | stainless steel | | | | |
| 1200* | 1 | shaft sleeve | bronze | | | | |
| 1210 | 1 | throttling bush | bronze | | | | |
| 1215 | 3 | Allen screw | stainless steel | | | | |
| 1220* | 1 | mechanical seal | -- | | | | |
| 1320* | 1 | gasket | -- | | | | |
| 1340* | 1 | gasket | -- | | | | |
| 1420 | 1 | pipe | stainless steel | | | | |
| 1430 | 2 | male connector | stainless steel | | | | |
| 1820* | 1 | cap nut | stainless steel | | | | |
| 1860* | 1/2 ^(*) | key | stainless steel | | | | |
| 1905* | 1 | O-ring | AR/NBR | | | | |
| 2100 | 1 | bearing bracket | cast iron | | | | |

| Item | Quantity | Description | Materials | | | | |
|-------|----------|------------------------------|-----------------|----|----|----|----|
| | | | G1 | G2 | G3 | B2 | B3 |
| 2110 | 1 | bearing cover | cast iron | | | | |
| 2170 | 1 | grease nipple | steel | | | | |
| 2190 | 1 | grease nipple | steel | | | | |
| 2200* | 1 | pump shaft | stainless steel | | | | |
| 2210* | 1 | key | steel | | | | |
| 2250* | 1 | ball bearing | -- | | | | |
| 2260* | 2 | angular contact ball bearing | -- | | | | |
| 2270* | 1 | oil seal | rubber | | | | |
| 2290* | 1 | adjusting ring | steel | | | | |
| 2300* | 1 | wave washer | steel | | | | |
| 2310 | 1 | grease control disk | stainless steel | | | | |
| 2315 | 1 | grease control disk | stainless steel | | | | |
| 2320* | 1 | oil seal | rubber | | | | |
| 2370 | 1 | lock nut | steel | | | | |
| 2380* | 1 | locking washer | steel | | | | |
| 2400 | 1 | name plate | stainless steel | | | | |
| 2410 | 1 | arrow plate | aluminium | | | | |
| 2800 | 4 | Allen screw | stainless steel | | | | |
| 2830 | 6 | Allen screw | stainless steel | | | | |
| 2835 | 6 | washer | stainless steel | | | | |

alu.brz = aluminium bronze

(*) Quantity depends on pump type

9.5 Pump construction K4

9.5.1 Sectional drawing 200-400, 250-250, 250-315, 300-250, 300-315

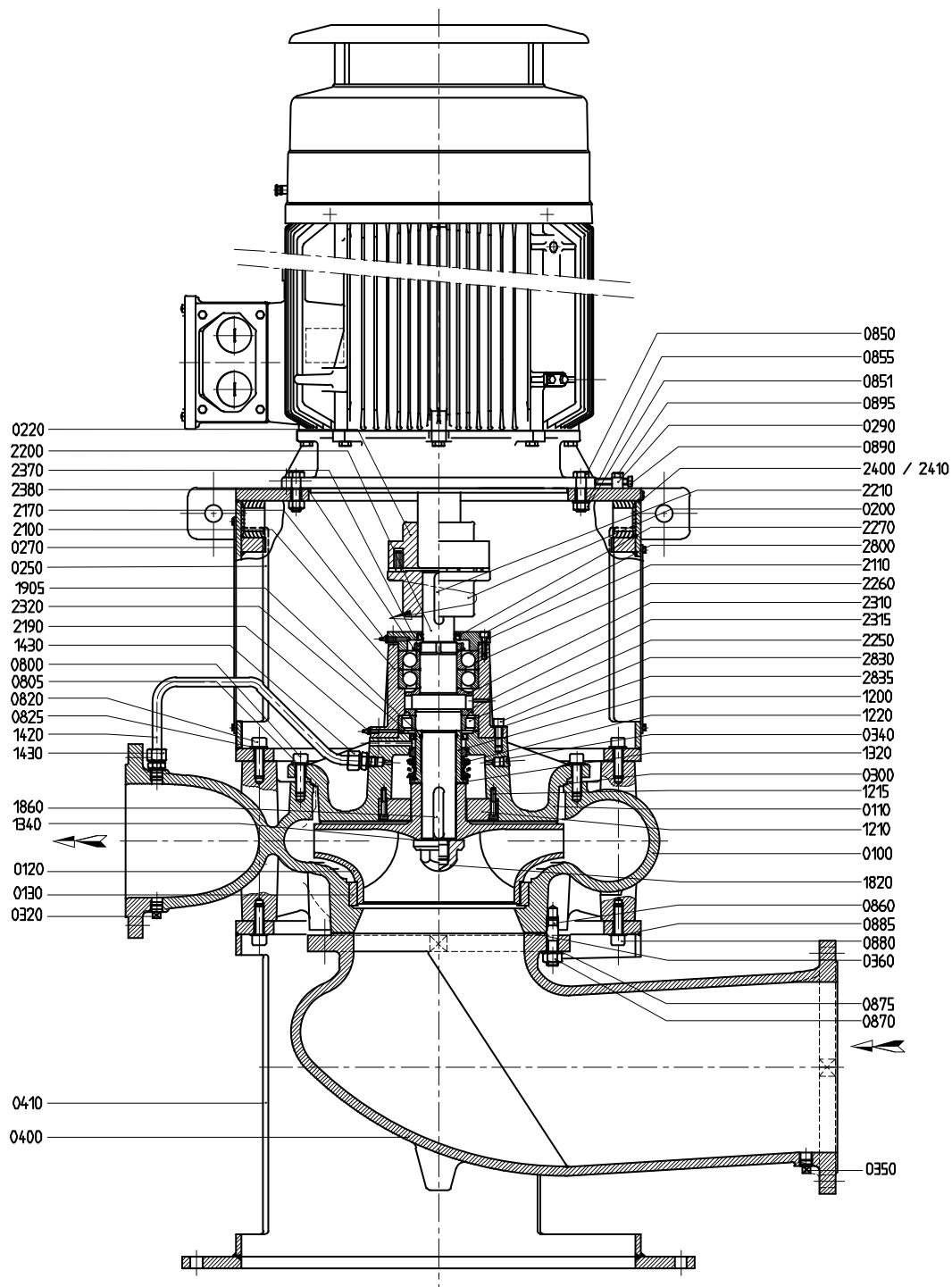

Figure 32: Sectional drawing 200-400, 250-250, 250-315, 300-250, 300-315.

9.5.2 Parts list 200-400, 250-250, 250-315, 300-250, 300-315

See figure 32.

| Item | Quantity | Description | Materials | | | | |
|-------|----------------------|---------------------------|-----------------|--------|---------|--------|---------|
| | | | G1 | G2 | G3 | B2 | B3 |
| 0100 | 1 | pump casing | cast iron | | | bronze | |
| 0110 | 1 | pump cover | cast iron | | | bronze | |
| 0120* | 1 | impeller | cast iron | bronze | alu.brz | bronze | alu.brz |
| 0130* | 1 | wear ring | cast iron | bronze | | | |
| 0200 | 1 | coupling half, pump side | cast iron | | | | |
| 0220 | 1 | coupling half, motor side | cast iron | | | | |
| 0250 | 1 | lantern piece | steel | | | | |
| 0270 | 2 | guard | stainless steel | | | | |
| 0290 | 4 | adjusting cam | stainless steel | | | | |
| 0300* | 1 | gasket | -- | | | | |
| 0320 | 1 | plug | stainless steel | | | | |
| 0340 | 1 | plug | stainless steel | | | | |
| 0350 | 1 | plug | stainless steel | | | | |
| 0360 | 1 | gasket | -- | | | | |
| 0400 | 1 | suction bend | cast iron | | | | bronze |
| 0410 | 1 | support | steel | | | | |
| 0800 | 12/16 ^(*) | Allen screw | stainless steel | | | | |
| 0805 | 12/16 ^(*) | washer | stainless steel | | | | |
| 0820 | 8 | Allen screw | stainless steel | | | | |
| 0825 | 8 | washer | stainless steel | | | | |
| 0850 | 4/8 ^(*) | bolt | stainless steel | | | | |
| 0851 | 4/8 ^(*) | nut | stainless steel | | | | |
| 0855 | 4/8 ^(*) | washer | stainless steel | | | | |
| 0860 | 12/16 ^(*) | stud | stainless steel | | | | |
| 0870 | 12/16 ^(*) | nut | stainless steel | | | | |
| 0875 | 12/16 ^(*) | washer | stainless steel | | | | |
| 0880 | 8 | Allen screw | stainless steel | | | | |
| 0885 | 8 | washer | stainless steel | | | | |
| 0890 | 4 | bolt | stainless steel | | | | |
| 0895 | 4/8 ^(*) | bolt | stainless steel | | | | |
| 1200* | 1 | shaft sleeve | bronze | | | | |
| 1210 | 1 | throttling bush | bronze | | | | |
| 1215 | 3 | Allen screw | stainless steel | | | | |
| 1220* | 1 | mechanical seal | -- | | | | |
| 1320* | 1 | gasket | -- | | | | |
| 1340* | 1 | gasket | -- | | | | |
| 1420 | 1 | pipe | stainless steel | | | | |
| 1430 | 2 | male connector | stainless steel | | | | |
| 1820* | 1 | cap nut | stainless steel | | | | |
| 1860* | 1 | key | stainless steel | | | | |
| 1905* | 1 | O-ring | AR/NBR | | | | |
| 2100 | 1 | bearing bracket | cast iron | | | | |
| 2110 | 1 | bearing cover | cast iron | | | | |

| Item | Quantity | Description | Materials | | | | |
|-------|----------|------------------------------|-----------------|----|----|----|----|
| | | | G1 | G2 | G3 | B2 | B3 |
| 2170 | 1 | grease nipple | steel | | | | |
| 2190 | 1 | grease nipple | steel | | | | |
| 2200* | 1 | pump shaft | stainless steel | | | | |
| 2210* | 1 | key | steel | | | | |
| 2250* | 1 | cylindrical roller bearing | -- | | | | |
| 2260* | 2 | angular contact ball bearing | -- | | | | |
| 2270* | 1 | oil seal | rubber | | | | |
| 2310 | 1 | grease control disk | stainless steel | | | | |
| 2315 | 1 | grease control disk | stainless steel | | | | |
| 2320* | 1 | oil seal | rubber | | | | |
| 2370 | 1 | lock nut | steel | | | | |
| 2380* | 1 | locking washer | steel | | | | |
| 2400 | 1 | name plate | stainless steel | | | | |
| 2410 | 1 | arrow plate | aluminium | | | | |
| 2800 | 4 | Allen screw | stainless steel | | | | |
| 2830 | 6 | Allen screw | stainless steel | | | | |
| 2835 | 6 | washer | stainless steel | | | | |

alu.brz = aluminium bronze

(*) Quantity depends on pump type

9.5.3 Sectional drawing 150B-400, 150-500, 200-250, 200-315

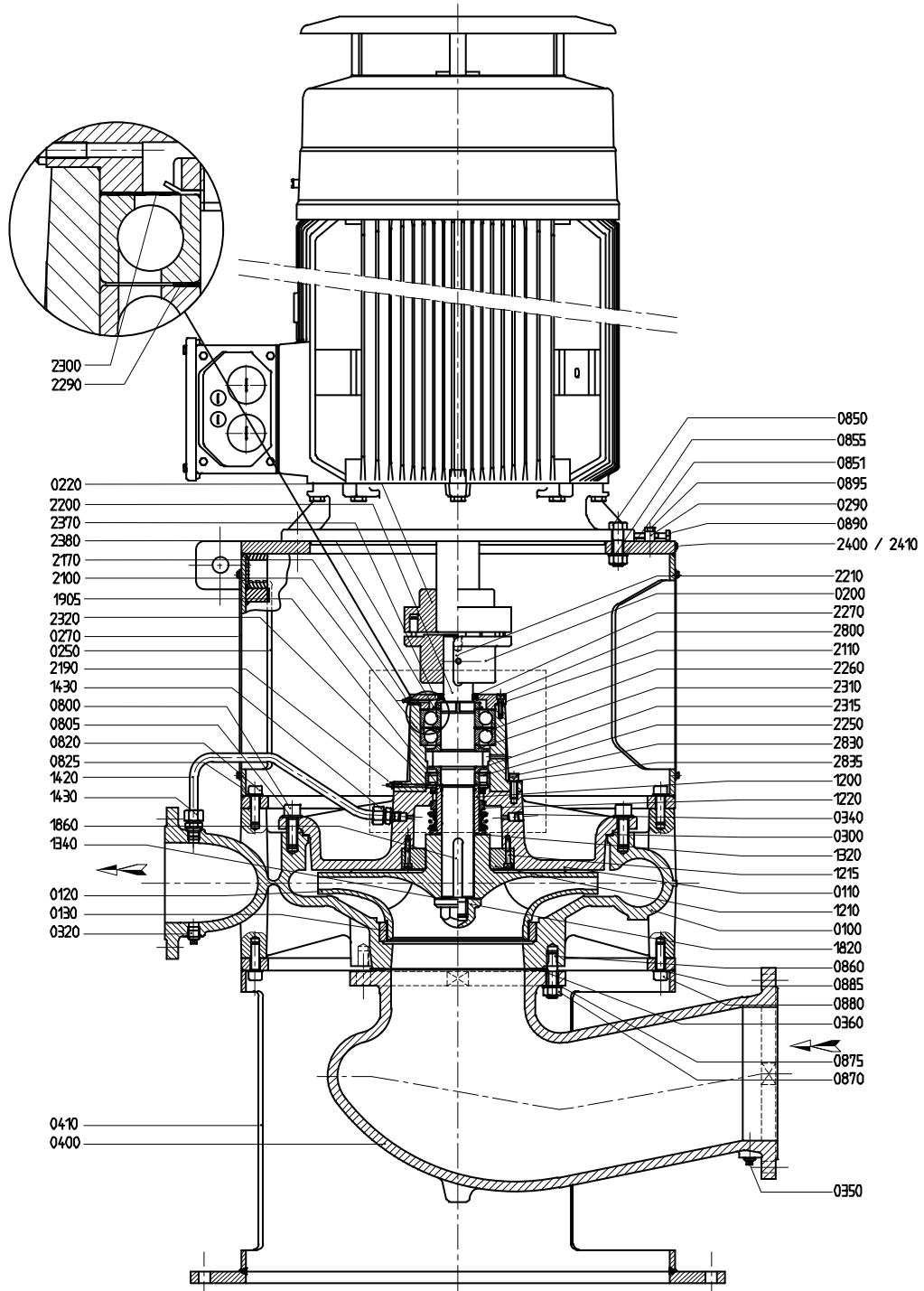

Figure 33: Sectional drawing 150B-400, 150-500, 200-250, 200-315.

9.5.4 Parts list 150B-400, 150-500, 200-250, 200-315

See figure 33.

| Item | Quantity | Description | Materials | | | | |
|-------|----------------------|---------------------------|-----------------|--------|---------|--------|---------|
| | | | G1 | G2 | G3 | B2 | B3 |
| 0100 | 1 | pump casing | cast iron | | | bronze | |
| 0110 | 1 | pump cover | cast iron | | | bronze | |
| 0120* | 1 | impeller | cast iron | bronze | alu.brz | bronze | alu.brz |
| 0130* | 1 | wear ring | cast iron | bronze | | | |
| 0200 | 1 | coupling half, pump side | cast iron | | | | |
| 0220 | 1 | coupling half, motor side | cast iron | | | | |
| 0250 | 1 | lantern piece | steel | | | | |
| 0270 | 2 | guard | stainless steel | | | | |
| 0290 | 4 | adjusting cam | stainless steel | | | | |
| 0300* | 1 | gasket | -- | | | | |
| 0320 | 1 | plug | stainless steel | | | | |
| 0340 | 1 | plug | stainless steel | | | | |
| 0350 | 1 | plug | stainless steel | | | | |
| 0360 | 1 | gasket | -- | | | | |
| 0400 | 1 | suction bend | cast iron | | | | bronze |
| 0410 | 1 | support | steel | | | | |
| 0800 | 12/16 ^(*) | Allen screw | stainless steel | | | | |
| 0805 | 12/16 ^(*) | washer | stainless steel | | | | |
| 0820 | 8 | Allen screw | stainless steel | | | | |
| 0825 | 8 | washer | stainless steel | | | | |
| 0850 | 4/8 ^(*) | bolt | stainless steel | | | | |
| 0851 | 4/8 ^(*) | nut | stainless steel | | | | |
| 0855 | 4/8 ^(*) | washer | stainless steel | | | | |
| 0860 | 12/16 ^(*) | stud | stainless steel | | | | |
| 0870 | 12/16 ^(*) | nut | stainless steel | | | | |
| 0875 | 12/16 ^(*) | washer | stainless steel | | | | |
| 0880 | 8 | Allen screw | stainless steel | | | | |
| 0885 | 8 | washer | stainless steel | | | | |
| 0890 | 4 | bolt | stainless steel | | | | |
| 0895 | 4/8 ^(*) | bolt | stainless steel | | | | |
| 1200* | 1 | shaft sleeve | bronze | | | | |
| 1210 | 1 | throttling bush | bronze | | | | |
| 1215 | 3 | Allen screw | stainless steel | | | | |
| 1220* | 1 | mechanical seal | -- | | | | |
| 1320* | 1 | gasket | -- | | | | |
| 1340* | 1 | gasket | -- | | | | |
| 1420 | 1 | pipe | stainless steel | | | | |
| 1430 | 2 | male connector | stainless steel | | | | |
| 1820* | 1 | cap nut | stainless steel | | | | |
| 1860* | 1/2 ^(*) | key | stainless steel | | | | |
| 1905* | 1 | O-ring | AR/NBR | | | | |
| 2100 | 1 | bearing bracket | cast iron | | | | |
| 2110 | 1 | bearing cover | cast iron | | | | |

| Item | Quantity | Description | Materials | | | | |
|-------|----------|------------------------------|-----------------|----|----|----|----|
| | | | G1 | G2 | G3 | B2 | B3 |
| 2170 | 1 | grease nipple | steel | | | | |
| 2190 | 1 | grease nipple | steel | | | | |
| 2200* | 1 | pump shaft | stainless steel | | | | |
| 2210* | 1 | key | steel | | | | |
| 2250* | 1 | cylindrical roller bearing | -- | | | | |
| 2260* | 2 | angular contact ball bearing | -- | | | | |
| 2270* | 1 | oil seal | rubber | | | | |
| 2290* | 1 | adjusting ring | steel | | | | |
| 2300* | 1 | wave washer | steel | | | | |
| 2310 | 1 | grease control disk | stainless steel | | | | |
| 2315 | 1 | grease control disk | stainless steel | | | | |
| 2320* | 1 | oil seal | rubber | | | | |
| 2370 | 1 | lock nut | steel | | | | |
| 2380* | 1 | locking washer | steel | | | | |
| 2400 | 1 | name plate | stainless steel | | | | |
| 2410 | 1 | arrow plate | aluminium | | | | |
| 2800 | 4 | Allen screw | stainless steel | | | | |
| 2830 | 6 | Allen screw | stainless steel | | | | |
| 2835 | 6 | washer | stainless steel | | | | |

alu.brz = aluminium bronze

(*) Quantity depends on pump type

9.5.5 Sectional drawing 125-500

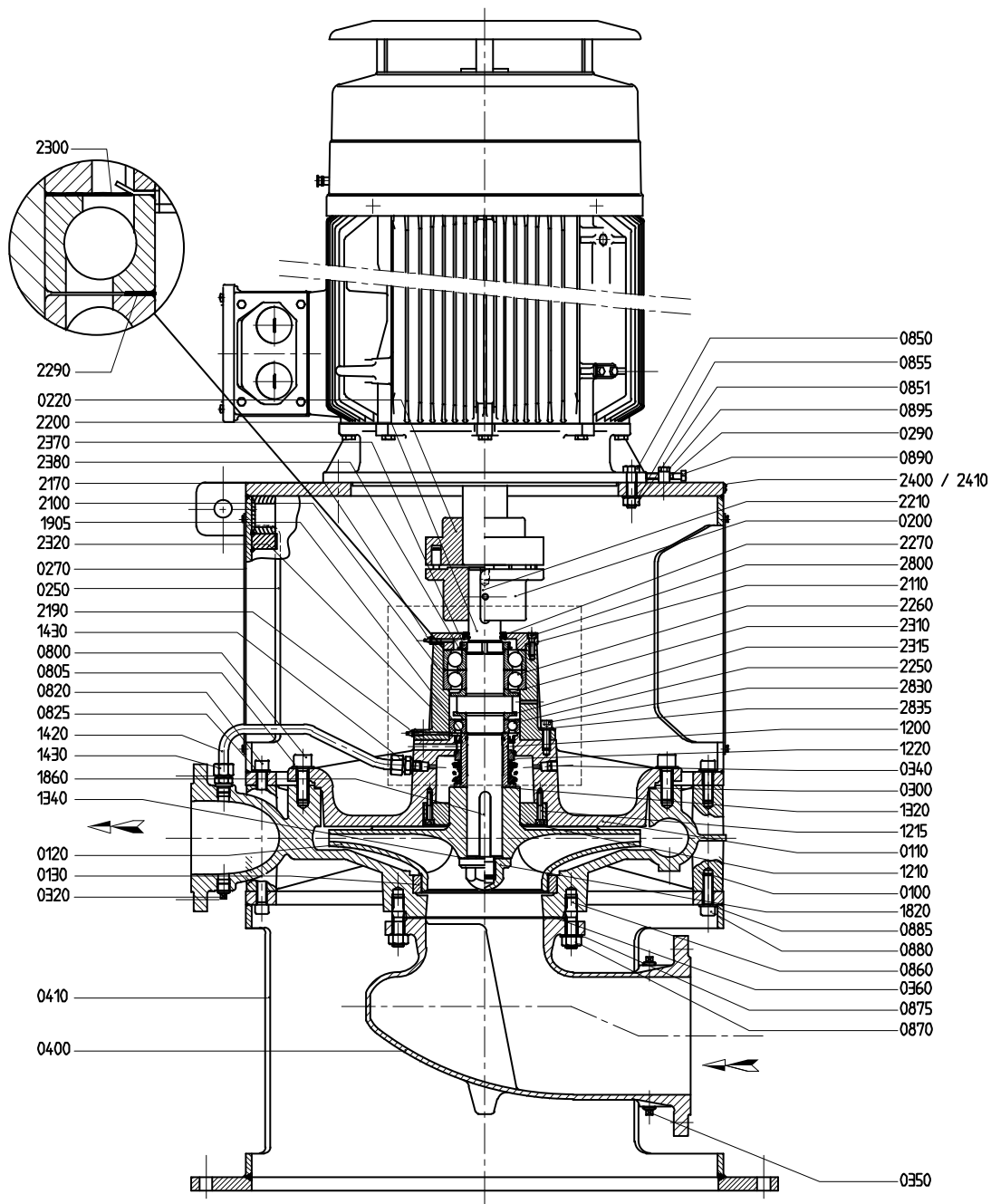

Figure 34: Sectional drawing 125-500.

9.5.6 Parts list 125-500

See figure 34.

| Item | Quantity | Description | Materials | | | | |
|-------|----------------------|---------------------------|-----------------|--------|---------|--------|---------|
| | | | G1 | G2 | G3 | B2 | B3 |
| 0100 | 1 | pump casing | cast iron | | | bronze | |
| 0110 | 1 | pump cover | cast iron | | | bronze | |
| 0120* | 1 | impeller | cast iron | bronze | alu.brz | bronze | alu.brz |
| 0130* | 1 | wear ring | cast iron | bronze | | | |
| 0200 | 1 | coupling half, pump side | cast iron | | | | |
| 0220 | 1 | coupling half, motor side | cast iron | | | | |
| 0250 | 1 | lantern piece | steel | | | | |
| 0270 | 2 | guard | stainless steel | | | | |
| 0290 | 4 | adjusting cam | stainless steel | | | | |
| 0300* | 1 | gasket | -- | | | | |
| 0320 | 1 | plug | stainless steel | | | | |
| 0340 | 1 | plug | stainless steel | | | | |
| 0350 | 1 | plug | stainless steel | | | | |
| 0360 | 1 | gasket | -- | | | | |
| 0400 | 1 | suction bend | cast iron | | | | bronze |
| 0410 | 1 | support | steel | | | | |
| 0800 | 12/16 ^(*) | Allen screw | stainless steel | | | | |
| 0805 | 12/16 ^(*) | washer | stainless steel | | | | |
| 0820 | 8 | Allen screw | stainless steel | | | | |
| 0825 | 8 | washer | stainless steel | | | | |
| 0850 | 4/8 ^(*) | bolt | stainless steel | | | | |
| 0851 | 4/8 ^(*) | nut | stainless steel | | | | |
| 0855 | 4/8 ^(*) | washer | stainless steel | | | | |
| 0860 | 12/16 ^(*) | stud | stainless steel | | | | |
| 0870 | 12/16 ^(*) | nut | stainless steel | | | | |
| 0875 | 12/16 ^(*) | washer | stainless steel | | | | |
| 0880 | 8 | Allen screw | stainless steel | | | | |
| 0885 | 8 | washer | stainless steel | | | | |
| 0890 | 4 | bolt | stainless steel | | | | |
| 0895 | 4/8 ^(*) | bolt | stainless steel | | | | |
| 1200* | 1 | shaft sleeve | bronze | | | | |
| 1210 | 1 | throttling bush | bronze | | | | |
| 1215 | 3 | Allen screw | stainless steel | | | | |
| 1220* | 1 | mechanical seal | -- | | | | |
| 1320* | 1 | gasket | -- | | | | |
| 1340* | 1 | gasket | -- | | | | |
| 1420 | 1 | pipe | stainless steel | | | | |
| 1430 | 2 | male connector | stainless steel | | | | |
| 1820* | 1 | cap nut | stainless steel | | | | |
| 1860* | **** | key | stainless steel | | | | |
| 1905* | 1 | O-ring | AR/NBR | | | | |
| 2100 | 1 | bearing bracket | cast iron | | | | |
| 2110 | 1 | bearing cover | cast iron | | | | |

| Item | Quantity | Description | Materials | | | | |
|-------|----------|------------------------------|-----------------|----|----|----|----|
| | | | G1 | G2 | G3 | B2 | B3 |
| 2170 | 1 | grease nipple | steel | | | | |
| 2190 | 1 | grease nipple | steel | | | | |
| 2200* | 1 | pump shaft | stainless steel | | | | |
| 2210* | 1 | key | steel | | | | |
| 2250* | 1 | ball bearing | -- | | | | |
| 2260* | 2 | angular contact ball bearing | -- | | | | |
| 2270* | 1 | oil seal | rubber | | | | |
| 2290* | 1 | adjusting ring | steel | | | | |
| 2300* | 1 | wave washer | steel | | | | |
| 2310 | 1 | grease control disk | stainless steel | | | | |
| 2315 | 1 | grease control disk | stainless steel | | | | |
| 2320* | 1 | oil seal | rubber | | | | |
| 2370 | 1 | lock nut | steel | | | | |
| 2380* | 1 | locking washer | steel | | | | |
| 2400 | 1 | name plate | stainless steel | | | | |
| 2410 | 1 | arrow plate | aluminium | | | | |
| 2800 | 4 | Allen screw | stainless steel | | | | |
| 2830 | 6 | Allen screw | stainless steel | | | | |
| 2835 | 6 | washer | stainless steel | | | | |

alu.brz = aluminium bronze

(*) Quantity depends on pump type

9.6 Suction bend K1/K2

9.6.1 Sectional drawing suction bend

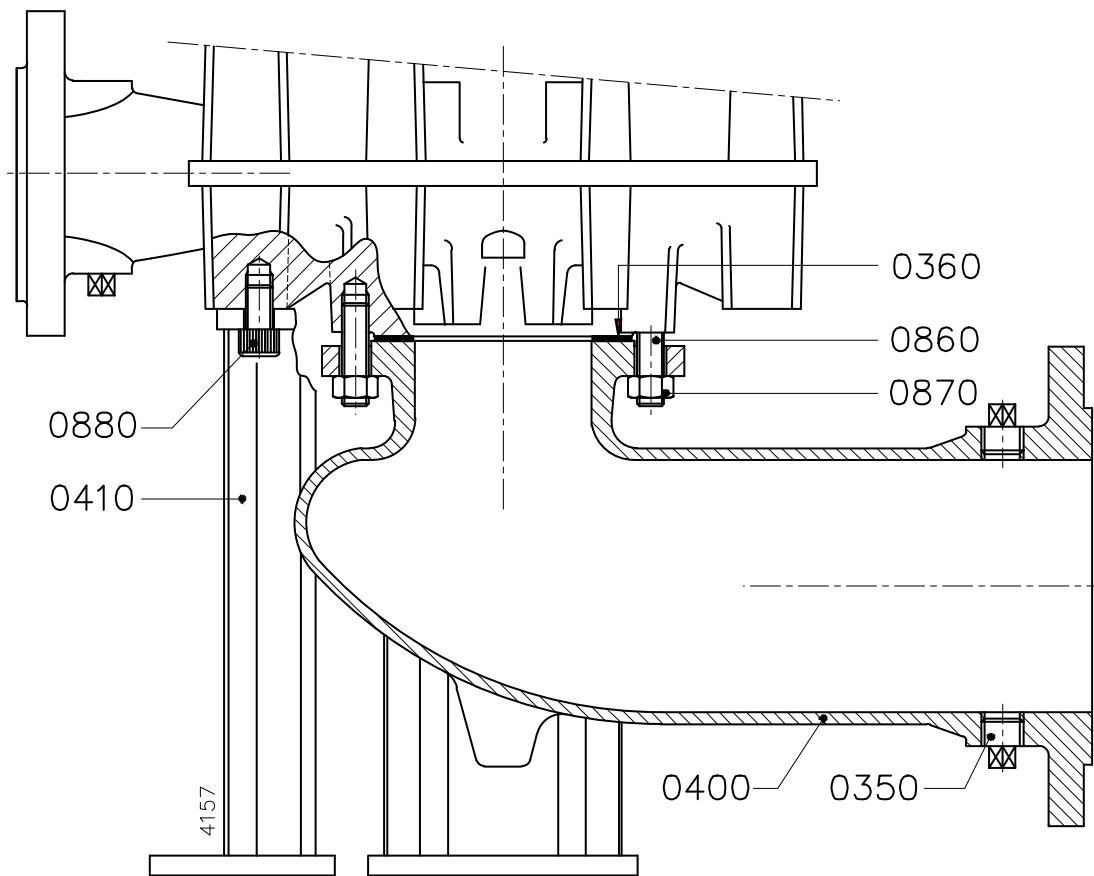

Figure 35: Sectional drawing suction bend.

9.6.2 Parts of suction bend

See figure 35.

| Item | Quantity | Description | Materials | |
|------|--------------------|--------------|-----------|-----------------|
| | | | cast iron | bronze |
| 0350 | 2 | plug | steel | stainless steel |
| 0360 | 1 | gasket | rubber | |
| 0400 | 1 | suction bend | cast iron | bronze |
| 0410 | 3 | support | steel | |
| 0860 | 4/8 ^(*) | stud | steel | |
| 0870 | 4/8 ^(*) | nut | steel | |
| 0880 | 6 | Allen screw | steel | |

(*) Quantity depends on pump type

9.6.3 Sectional drawing suction bend 200-200 / 250B-315

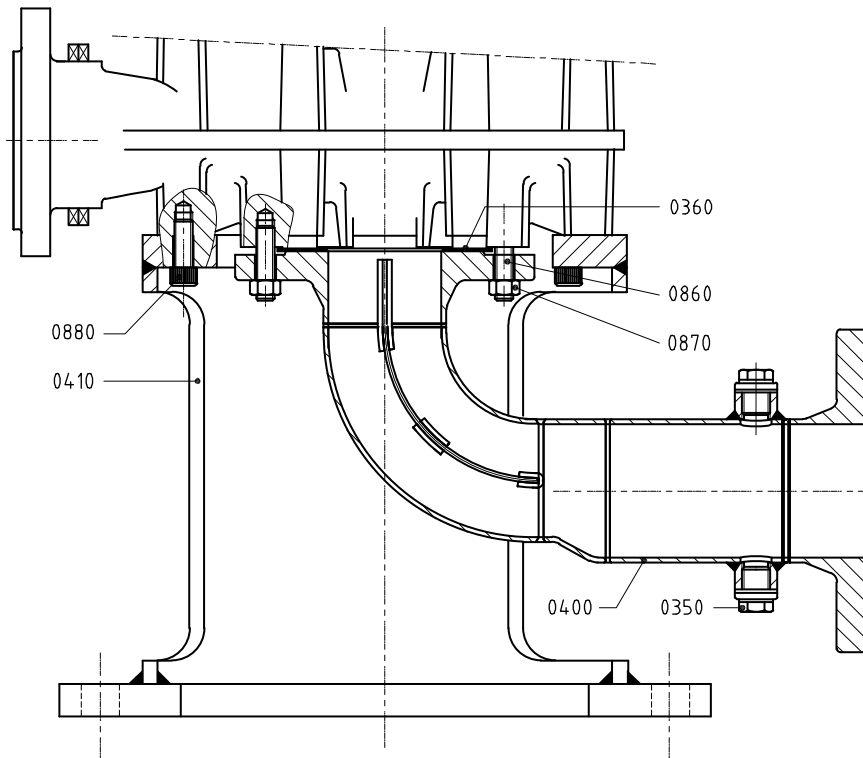

Figure 36: Sectional drawing suction bend 200-200 / 250B-315.

9.6.4 Parts of suction bend 200-200 / 250B-315

See figure 36.

| Item | Quantity | Description | Materials | |
|------|--------------------|--------------|-----------|-----------------|
| | | | cast iron | bronze |
| 0350 | 2 | plug | steel | stainless steel |
| 0360 | 1 | gasket | rubber | |
| 0400 | 1 | suction bend | steel | duplex |
| 0410 | 1 | support | steel | |
| 0860 | 4/8 ^(*) | stud | steel | |
| 0870 | 4/8 ^(*) | nut | steel | |
| 0880 | 8 | Allen screw | steel | |

(*) Quantity depends on pump type

10 Technical data

10.1 Grease

Table 6: Recommended greases according to NLGI-3 classification.

| | |
|------------|--------------------|
| BP | Energrease LS-EP 3 |
| CHEVRON | MultifaK Premium 3 |
| EXXONMOBIL | Beacon EP 3 |
| | Mobilux EP 3 |
| SHELL | Alvania RL3 |
| SKF | LGMT 3 |
| TOTAL | Total Lical EP 2 |

10.2 Quantity of grease for bracket group 4 bearings

Table 7: Quantity of grease for bracket group 4 bearings

| Pump type | Quantity of grease [gr] for post-greasing | | Quantity of grease [gr] for assembly | |
|-----------|---|---------------------------|--------------------------------------|---------------------------|
| | bearings at drive end | bearings at non-drive end | bearings at drive end | bearings at non-drive end |
| 125-500 | 46 | 14 | 180 | 55 |
| 150B-400 | | 16 | | 64 |
| 150-500 | | | | |
| 200-250 | | | | |
| 200-315 | | 18 | | 72 |
| 200-400 | | | | |
| 250-250 | 54 | 23 | 216 | 92 |
| 250-315 | | | | |
| 300-250 | | | | |
| 300-315 | | | | |

10.3 Recommended locking liquids

Table 8: Recommended locking liquids.

| Description | Locking liquid |
|------------------|----------------|
| rod (0250) | Loctite 243 |
| cap nut (1820) | |
| wear ring (0130) | Loctite 641 |

10.4 Tightening moments

10.4.1 Tightening moments for bolts and nuts

Table 9: Tightening moments for bolts and nuts.

| Materials | 8.8 | A2, A4 |
|-----------|------------------------|--------|
| Thread | Tightening moment [Nm] | |
| M6 | 9 | 6 |
| M8 | 20 | 14 |
| M10 | 40 | 25 |
| M12 | 69 | 43 |
| M16 | 168 | 105 |
| M20 | 324 | 180 |

10.4.2 Tightening moments for cap nut

Table 10: Tightening moments for cap nut (1820).

| Size | Tightening moment [Nm] |
|-----------------------|------------------------|
| M12 (bearing group 1) | 43 |
| M16 (bearing group 2) | 105 |
| M24 (bearing group 3) | 220 |
| M36 (bearing group 4) | 510 |

10.5 Maximum speed

Table 11: Maximum speed

| | max. speed [min ⁻¹] |
|-----------|---------------------------------|
| 32-160 | 3600 |
| 32-200 | 3600 |
| 40-160 | 3600 |
| 40-200 | 3600 |
| 40-250 | 3000 |
| 50-160 | 3600 |
| 50-200 | 3600 |
| 50-250 | 3000 |
| 65-160 | 3600 |
| 65-200 | 3600 |
| 65A-250 | 3000 |
| 65-315 | 2400 |
| 80-160 | 3600 |
| 80-200 | 3600 |
| 80(A)-250 | 3000 |
| 80-315 | 2400 |
| 80-400 | 1800 |
| 100C-200 | 3000 |
| 100-250 | 3000 |
| 100-315 | 2100 |
| 100-400 | 1800 |
| 125-250 | 1800 |

Table 11: Maximum speed

| | max. speed [min⁻¹] |
|----------|--------------------------------------|
| 125-315 | 2100 |
| 125-400 | 1800 |
| 125-500 | 1800 |
| 150-315 | 1800 |
| 150-400 | 1500 |
| 150B-400 | 1800 |
| 150-500 | 1800 |
| 200-200 | 1800 |
| 200-250 | 1800 |
| 200-315 | 1800 |
| 200-400 | 1800 |
| 250-250 | 1800 |
| 250-315 | 1800 |
| 250B-315 | 1800 |
| 300-250 | 1800 |
| 300-315 | 1800 |

10.6 Hydraulic performance

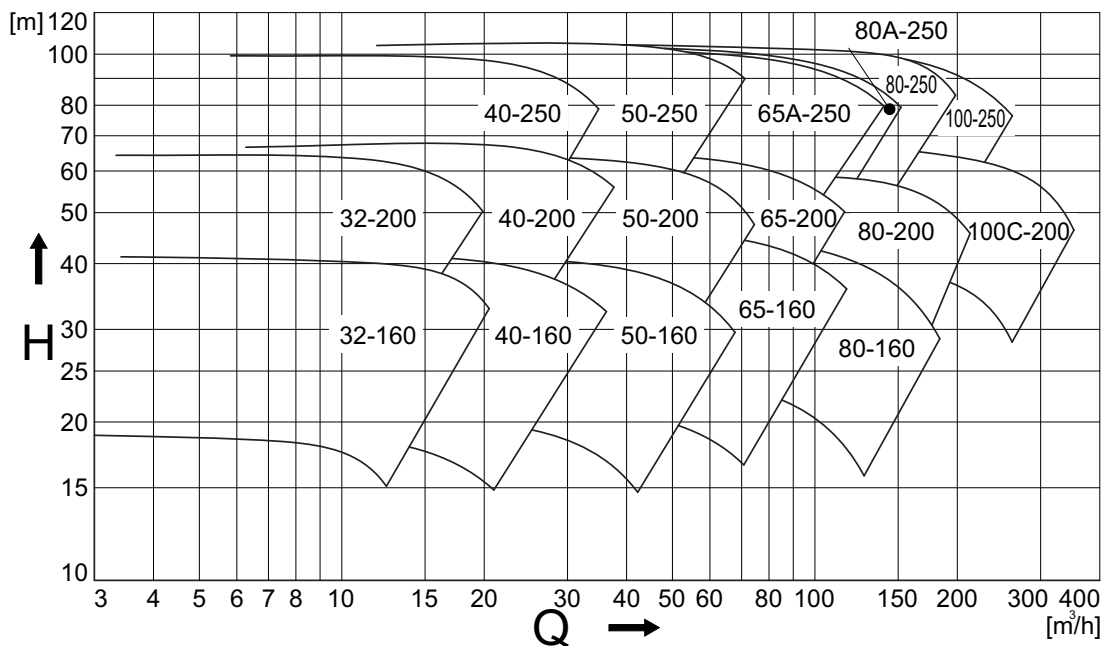

Figure 37: Performance overview 3000 min⁻¹

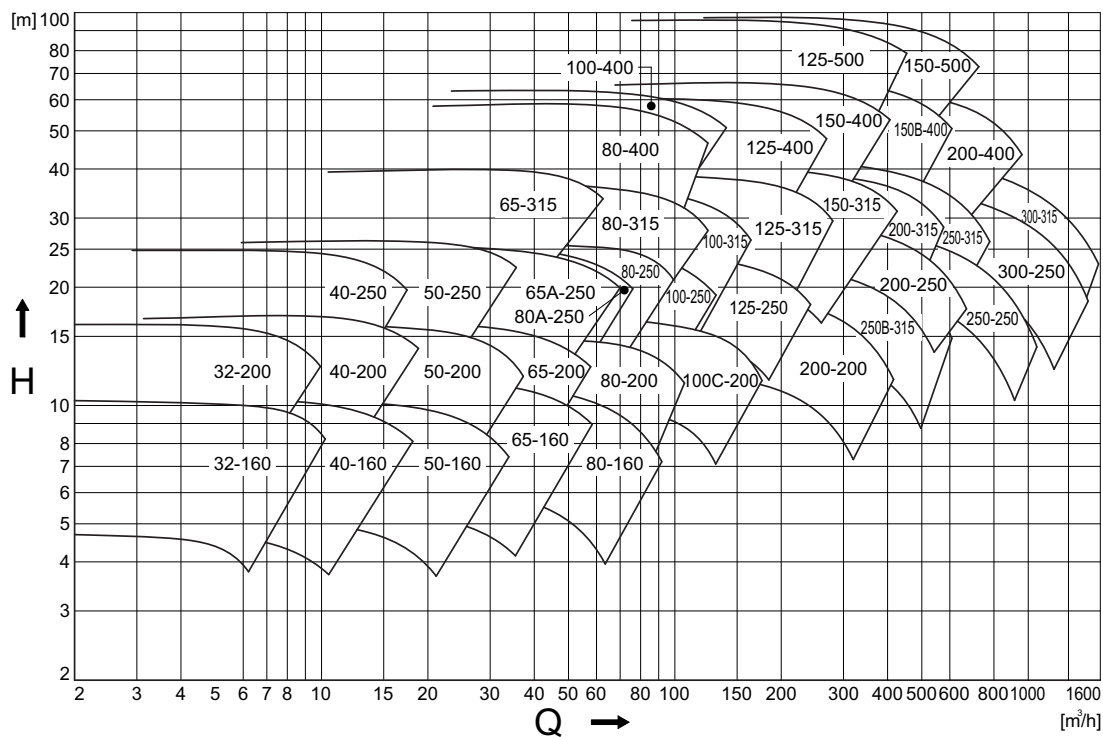

Figure 38: Performance overview 1500 min⁻¹

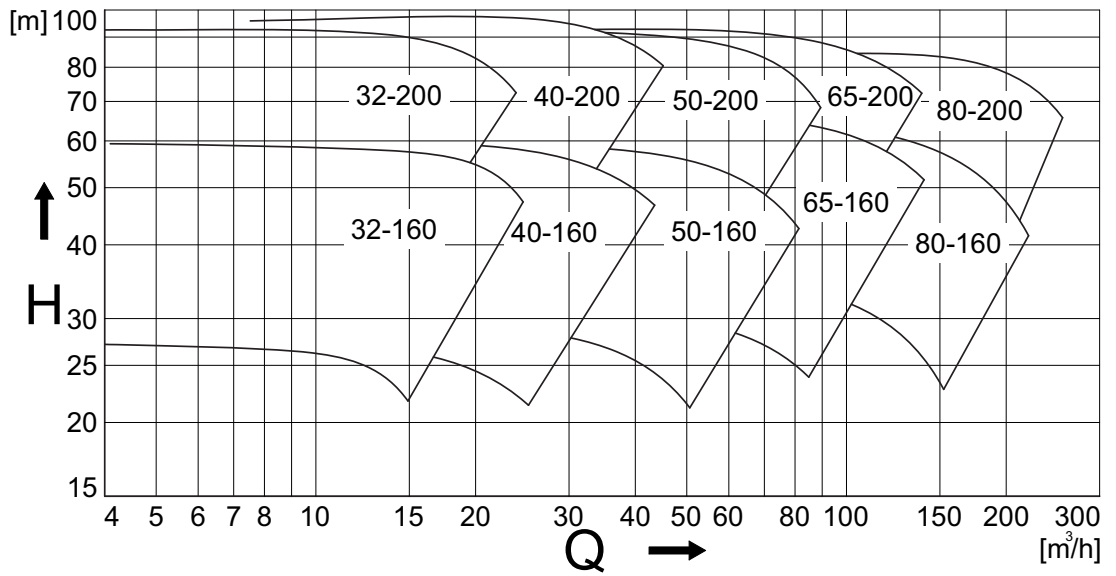

Figure 39: Performance overview 3600 min⁻¹

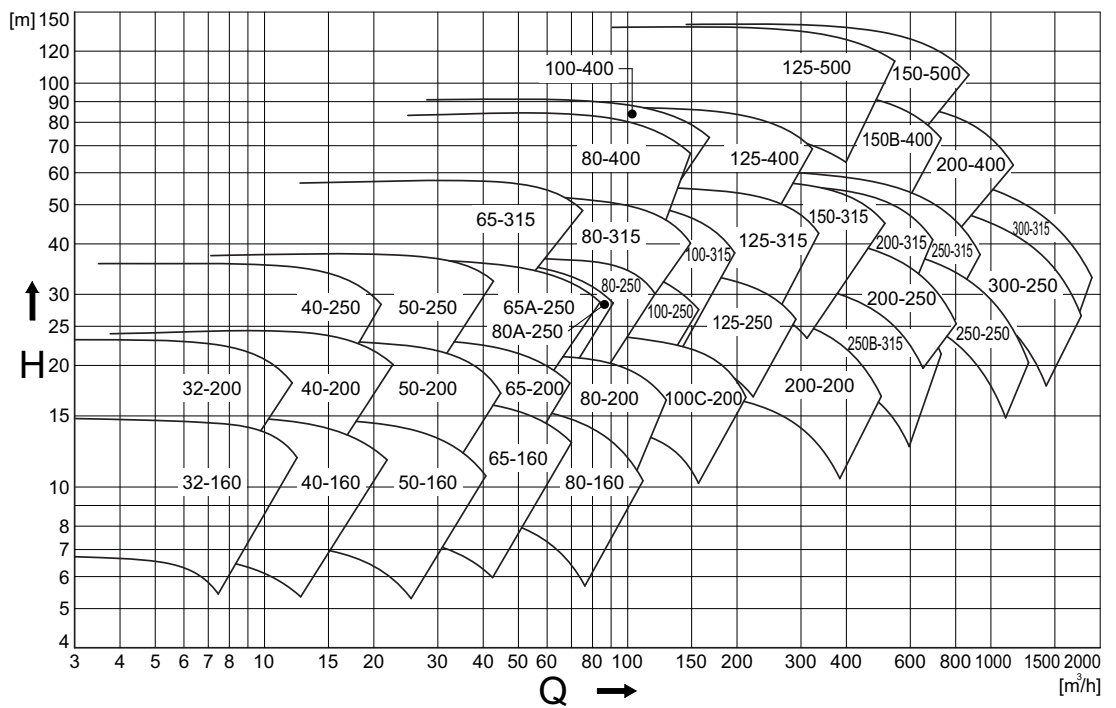

Figure 40: Performance overview 1800 min⁻¹

10.7 Noise data

10.7.1 Pump noise as a function of pump power

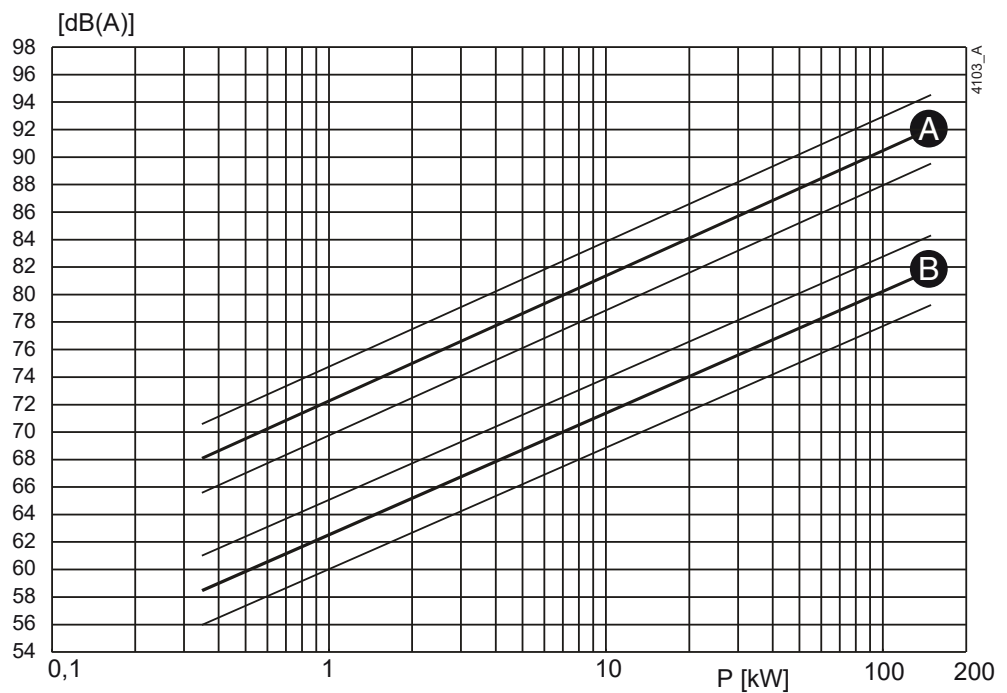

Figure 41: Noise level as function of pump power [kW] at 1450 min^{-1}
A = sound power level, B = sound pressure level.

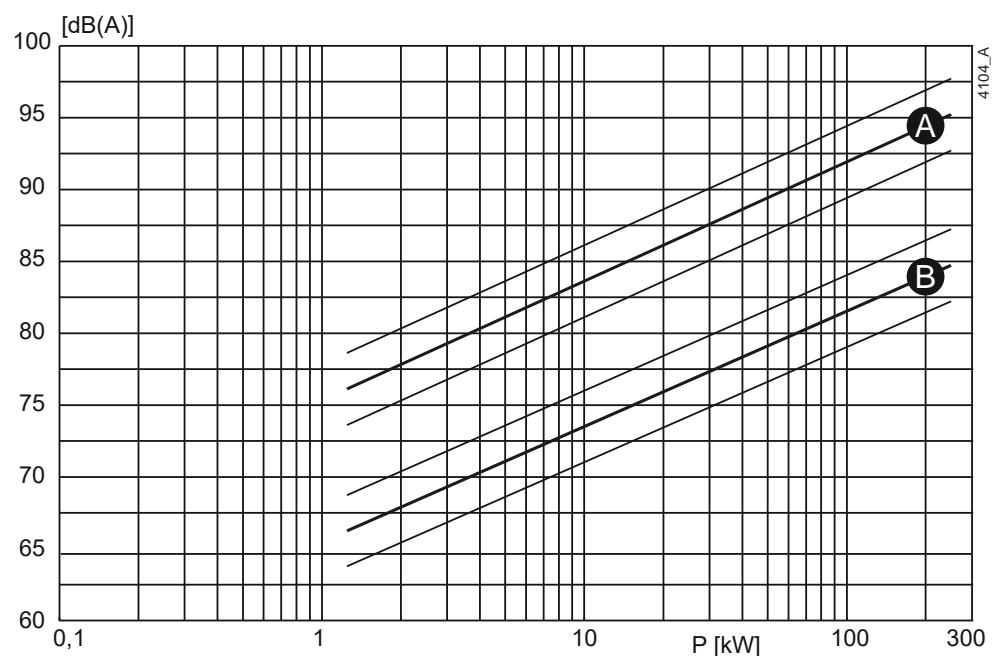

Figure 42: Noise level as function of pump power [kW] at 2900 min^{-1}
A = sound power level, B = sound pressure level.

10.7.2 Noise level of entire pump unit

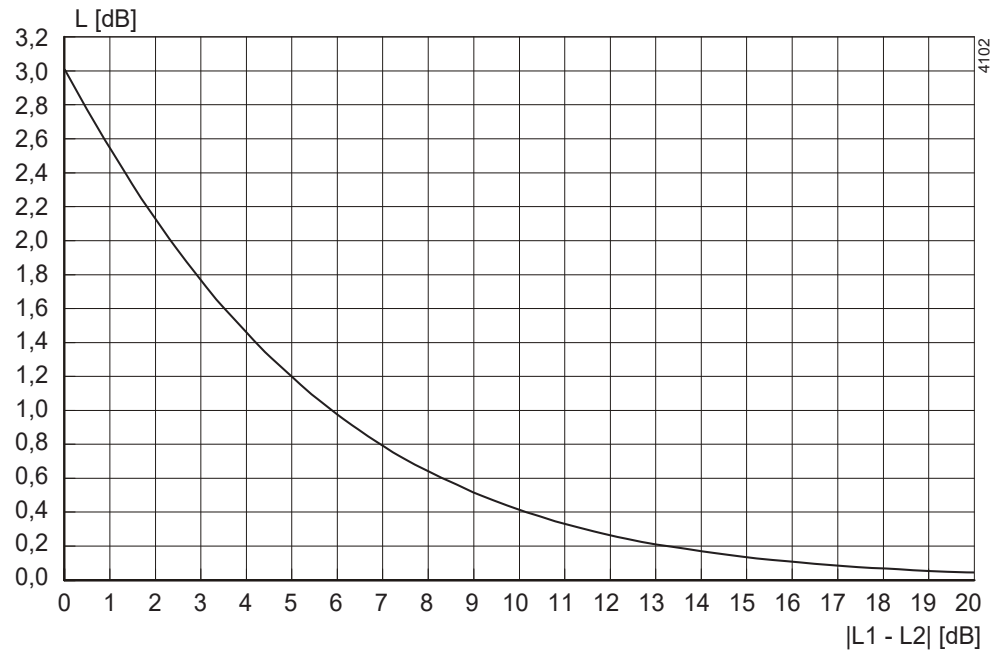

Figure 43: Noise level of entire pump unit.

In order to determine the total noise level of the entire pump unit, the noise level of the motor must be added to that of the pump. This can be easily done by using the graph above.

- 1 Determine the noise level (L1) of the pump, see figure 41 or figure 42.
- 2 Determine the noise level (L2) of the motor, see documentation of the motor.
- 3 Determine the difference between both levels $|L1 - L2|$.
- 4 Find the differential value on the $|L1 - L2|$ -axis and go up to the curve.
- 5 From the curve go left to the L[dB] -axis and read out the value.
- 6 Add this value to the highest value of both noise levels (L1 or L2).

Example:

- 1 Pump 75 dB; motor 78 dB.
- 2 $|75-78| = 3$ dB.
- 3 3 dB on the X-axis = 1,75 dB on the Y-axis.
- 4 Highest noise level + 1,75 dB = 78 + 1,75 = 79,75 dB.

Index

A

| | |
|------------------------|----|
| Application area | 16 |
| Applications | 14 |

B

| | |
|--------------------------------|----|
| Bearing groups | 14 |
| Bearings | |
| assembly instructions | 37 |
| disassembly instructions | 37 |
| lubrication | 25 |

C

| | |
|-----------------------------|----|
| Commissioning | 23 |
| Construction | 14 |
| pump casing/impeller | 15 |
| shaft sealing | 15 |
| Construction variants | 29 |
| Coupling | |
| alignment | 19 |
| alignment tolerances | 19 |
| fitting | 19 |

D

| | |
|----------------------------|----|
| Daily maintenance | 25 |
| mechanical seal | 25 |
| Designation of parts | 29 |

E

| | |
|--------------------------------|----|
| Earthing | 17 |
| Electric motor | |
| connecting | 21 |
| sense of rotation | 23 |
| Environment | 17 |
| Environmental influences | 25 |

F

| | |
|------------------|----|
| Faults | 26 |
| Foundation | 17 |

G

| | |
|--------------|----|
| Grease | 91 |
|--------------|----|

| | |
|-----------------|----|
| Guarantee | 10 |
|-----------------|----|

H

| | |
|----------------|----|
| Hoisting | 11 |
|----------------|----|

I

| | |
|-------------|----|
| Inspection | |
| motor | 23 |
| pump | 23 |

L

| | |
|-----------------------|----|
| Lifting eye | 11 |
| Liquid draining | 30 |
| Liquid level | 96 |

M

| | |
|----------------------------------|----|
| Maintenance staff | 9 |
| Mechanical seal | |
| assembly instructions | 35 |
| with Teflon covered O-ring | 35 |

N

| | |
|-------------|--------|
| Noise | 24, 25 |
|-------------|--------|

P

| | |
|------------------------------|----|
| Pallets | 10 |
| Piping | 21 |
| Position numbers | 29 |
| Precautionary measures | 29 |
| Pump description | 13 |

R

| | |
|----------------------------------|----|
| Recommended greases | 91 |
| Recommended locking liquid | 91 |
| Re-use | 16 |

S

| | |
|-----------------|-------|
| Safety | 9, 17 |
| symbols | 9 |
| Scrapping | 16 |

| | |
|--------------------------|--------|
| Sense of rotation | 23 |
| Serial number | 14 |
| Special tools | 29 |
| Start-up | 23 |
| Static electricity | 17 |
| Storage | 10, 12 |
| T | |
| Technicians | 9 |
| Tightening moments | |
| for bolts and nuts | 92 |
| for cap nut | 92 |
| Transport | 10 |
| Type description | 13 |
| U | |
| Unit | |
| assembling | 18 |
| mounting | 18 |
| placing | 18 |
| V | |
| Ventilation | 17 |
| W | |
| Wear ring | |
| assembly | 34 |
| disassembly | 34 |
| Weight | 10 |
| Working switch | 21 |

› Johnson Pump®

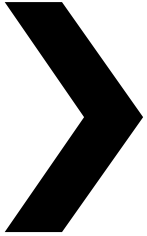

CombiFlex

Vertical centrifugal pump

SPXFLOW®

Dr. A. F. Philipsweg 51
9403 AD Assen
THE NETHERLANDS

P: + 31 (0) 592 37 67 67
F: + 31 (0) 592 37 67 60
E: johnson-pump.nl@spxflow.com

www.spxflow.com/johnson-pump

Improvements and research are continuous at SPX FLOW, Inc. Specifications may change without notice.

ISSUED 01/2023
Revision: CF/EN (2301) 6.7

Copyright © 2022 SPX FLOW, Inc.