

# DW Pump

ROTARY LOBE PUMPS

FORM NO.: L453194UK

REVISION: 12/2012

READ AND UNDERSTAND THIS MANUAL PRIOR TO OPERATING OR SERVICING THIS PRODUCT.



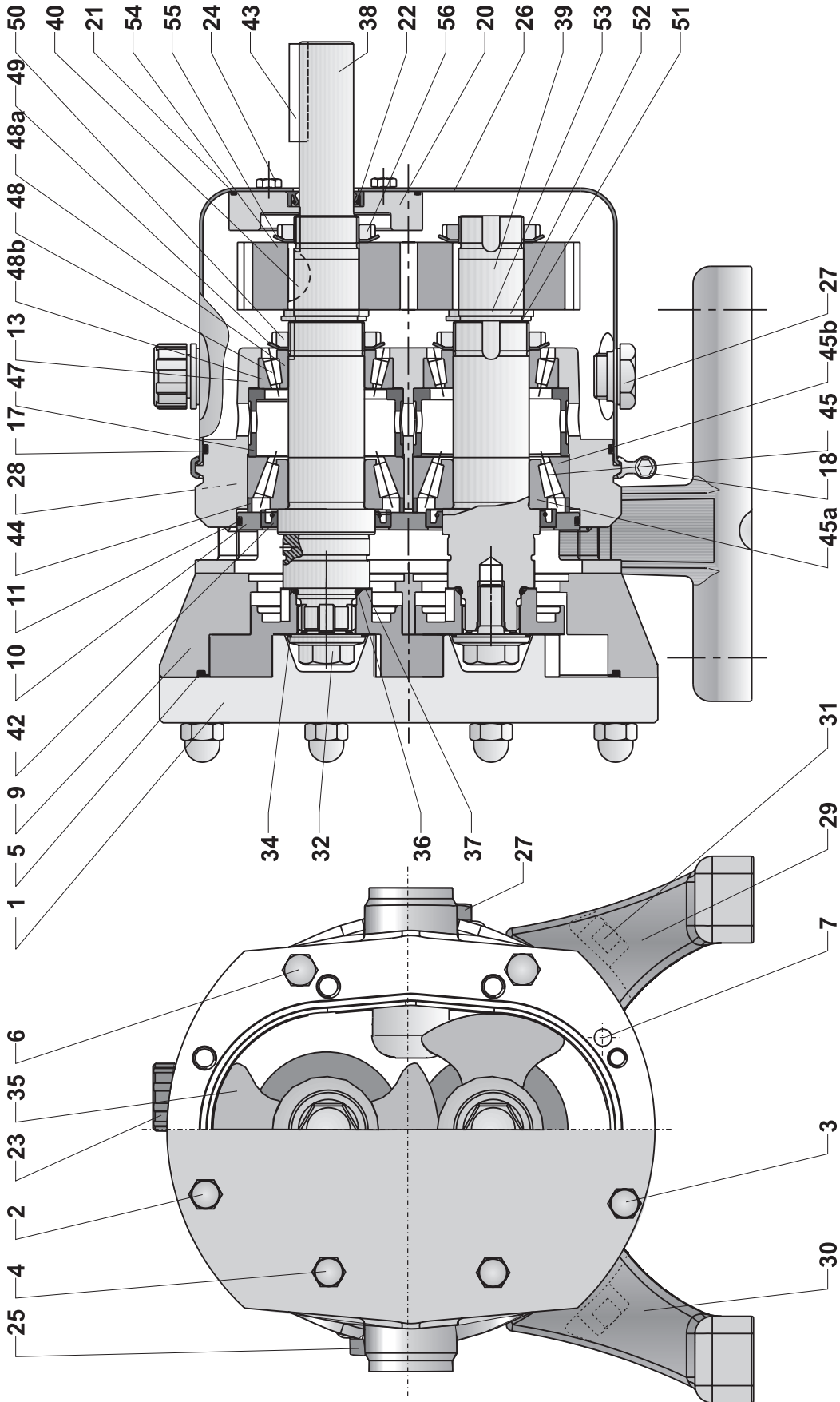


## Contents:

UK

Section	Page	Description	Section	Page	Description
-	2	Sectional Drawing - Pump	7.	-	<b>Spare parts list</b>
-	5	Sectional Drawing - Shaft seal	-	36	Pump complete
<b>0.</b>	<b>7</b>	<b>Warnings</b>	-	64	Shaft seal, single mechanical
<b>1.</b>	<b>8</b>	<b>Introduction to the DW range</b>	-	66	Baseplate
1.1	-	The DW range	-	67	Motorshroud complete
1.2	-	The DW Pump, options and extras	-	68	Motorshroud spare part
1.3	-	Identifying the pump model	-	70	Coupling guard
1.4	-	Identification of motor	-	72	Pump dimensions
<b>2.</b>	<b>9</b>	<b>Installation of the pump</b>	-	74	Pump dimensions with fittings
2.1	-	Handling and storage	-	75	Fitting tools for pump flushing
2.2	-	Positioning of the pump	-	76	Locking tool
2.3	-	The pipe system	-	77	Removal tool
2.4	-	Pump rotation			
2.5	-	Power supply			
2.6	10	Water supply for water flushed seals			
<b>3.</b>	<b>10</b>	<b>Before start-up and starting the pump</b>	<b>Separate Manuals</b>		
3.1	-	Checking the pump for foreign bodies	7.1	-	<b>Dimensional sketches</b>
3.2	-	Check the following before finishing the installation	-	-	Pump dimensions
3.3	11	Immediately after starting the pump	-	-	Pump dimensions with fittings
3.4	12	Fault finding	-	-	Dimensional sketches for complete arrangement
<b>4.</b>	<b>13</b>	<b>Dismantling and re-assembling the pump</b>	<b>8</b>	-	<b>Accessories</b>
4.1	-	Remove front cover	8.1	-	Shaft seal
4.1.1	-	Re-fit the front cover	8.2	-	Thermal jacket
4.2	-	Remove the rotors	8.3	-	Relief Valve
4.2.1	14	Re-fit the rotors	8.4	-	Rectangular inlet
4.3	-	Remove the rotor case	8.5	-	Electro polishing
4.3.1	-	Re-fit the rotor case			
4.4	15	Remove can			
4.4.1	-	Re-fit can			
4.5	-	Remove lipseal holder			
4.5.1	-	Re-fit lipseal holder			
4.6	-	Remove the timing gears			
4.6.1	16	Re-fit the timing gears			
4.7	-	Remove the oil seal plate			
4.7.1	-	Re-fit the oil seal plate			
4.8	17	Remove the foot			
4.8.1	-	Re-fit the foot			
4.9	-	Adjustment of the rotors axial position			
4.9.1	18	Adjustment of the rotors angular position			
<b>5.</b>	<b>19</b>	<b>Maintenance</b>			
5.1	-	Replacing rotors			
5.2	20	Replacement of single mechanical shaft seals			
5.3	-	Changing port orientation			
5.4	21	Changing the bearings			
5.5	22	Recommended holding of spare parts			
<b>6.</b>	<b>23</b>	<b>Technical data</b>			
6.1	-	Tightening Torque Settings			
6.2	24	Maximum differential and discharge pressures			
6.3	-	Maximum permissible moment			
6.4	-	Maximum permissible temperature			
6.5	-	Sound pressure and sound power level			
6.6	26	Temperature changes and max. temperature			
6.7	-	Maximum permissible rotational speed			
6.8	27	Clearance for adjustment			

Sectional Drawing, pump complete

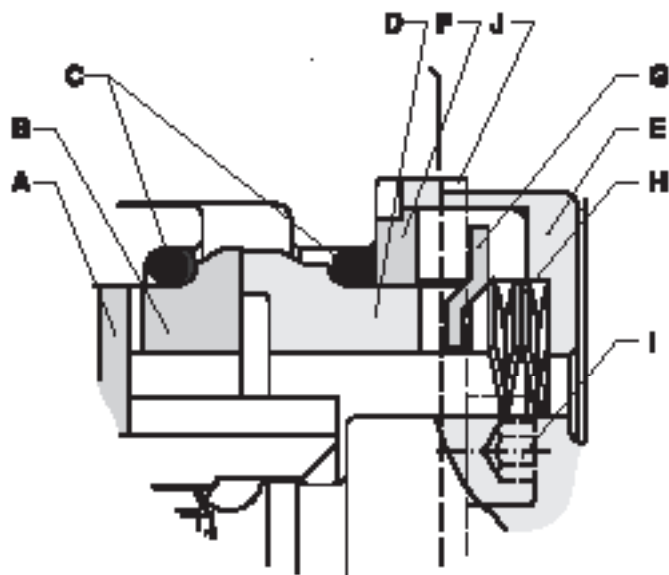


## Sectional Drawing, pump complete

Pos	Description
1	Front cover
2	Bolt, front cover
3	Bolt, front cover stepped
4	Nut, front cover dome
5	Gasket, front cover
6	Screw, rotor case to chassis
7	Dowel
9	Rotor case
10	Oil seal plate
11	O-ring, oil seal plate
13	Chassis
17	O-ring, can
18	Clamp ring
20	Seal consol
21	O-ring, seal consol
22	Oil seal rear
23	Oil filler plug
24	Screw, seal consol
25	Oil level window
26	Can
27	Oil drain plug
28	Nut
29	Foot, left
30	Foot, right
31	Screw for foot
32	Rotor screw with washer

Pos	Description
34	O-ring, rotor screw
35	Rotor
36	O-ring, rotor/shaft
37	Shims, rotor
38	Shaft main
39	Shaft aux
40	Gear key
42	Oil seal front
43	Drive key
44	Front spacer
45	Bearing front
45a	Bearing front, inner bearing race
45b	Bearing front, outer bearing race
47	Spacer, rear bearing
48	Bearing rear
48a	Bearing rear, inner bearing race
48b	Bearing rear, outer bearing race
49	Bearing rear tab washer
50	Bearing rear nut
51	Circlip
52	Gear spacer
53	Gear shims
54	Gear (1pair)
55	Gear tab washer
56	Gear nut

## Sectional drawing - Shaft seal



### Single mechanical seal

- A: Rotary drive ring
- B: Rotary seal face
- C: O-ring, seal
- D: Stationary seal face
- E: Seal housing
- F: Clamp plate
- G: Stationary drive ring
- H: Wave spring
- I: Screw, seal housing
- J: Clamp

## 0. Warnings



1. Read the instructions before installing and starting the pump. Always follow the guidelines for assembly in order to secure optimum operational reliability. If in doubt, contact your local APV dealer.

### Electrical Installation

2. Always check that the specifications of the motor and the motor control unit are correct, particularly in operating environments where there may be a risk of explosion.
3. Always ensure that all electrical installation is carried out by qualified staff.
4. Never hose down the electric motor directly with water or cleaning fluids.
5. Never dismantle the pump before the power supply to the motor has been disconnected. The fuses should be removed and the cable disconnected from the motor.
6. Pumps should only be installed, disassembled, repaired and assembled by personnel trained in servicing of APV pumps, or by APV fitters. For further information, please contact your local APV dealer.

### Personal Injury

7. Never start the pump before the coupling guard between pump and motor has been securely fitted.
8. There are rotating parts in the pump. Never put hands or fingers into a pump while it is in operation..
9. Never touch the gearbox of the pump as it can become very hot.
10. Never touch the rotor case during operation. If the pump is being used for hot fluids the rotor case may become very hot.
11. Always ensure that all pipe connections have been fitted and tightened properly before the pump is started. If the pump is used for hot and/or hazardous liquids, special care must be taken. In such cases, follow the local regulations for personal safety when working with these products.
12. Never dismantle the pump until the isolating valves on the suction and discharge side have been closed and the immediate pipe system has been drained. If the pump is used for hot and/or hazardous fluids, special precautions must be taken. In such cases follow the local regulations for personal safety when working with these products.

### Pump damage

13. Always remove assembly tools from the pump before starting it up.
14. Always ensure that no debris of any kind is present in the pump.
15. Always ensure that the pump is filled with liquid before it is started.
16. Always ensure that the pump and the motor shafts are properly aligned .
17. Always ensure that the suction and discharge valves isolating the pump are fully open before starting the pump.
18. Always use securely fitted lifting straps when lifting the pump with a hoist or similar lifting gear. Check whether there are any special lifting instructions.
19. Always ensure that the gearbox case is filled with an APV recommended gear oil to the appropriate level.
20. Never close or obstruct the outlet of the pump as the pressure in the system will increase above the specified maximum pressure of the pump and cause damage to the pump.
21. Never drop parts - especially rotors and front covers - on the floor.
22. Never exceed the maximum temperature specified on the pump nameplate.
23. Never exceed the maximum allowable pressure specified below:  
 Max. 33 bar: DW6 and DW7  
 Max. 28 bar: DW5  
 Max. 23 bar: DW2; DW3 and DW4  
 Max. 18 bar: DW1  
 These pressures apply for water at 20°C.  
 The differential pressure must not exceed the pressure stated on the nameplate.

## 1. Introduction to the DW range

### 1.1 The DW range

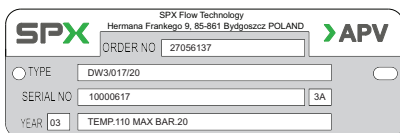
This manual covers all sizes of standard DW and DWE pumps as well as high temperature pumps. Check the nameplate of the pump to ensure that you have one of the above versions.

### 1.2 The DW Pump, options and extras

The following standard options are available in the DW range:

- Bareshaft pump
- Pump with constant speed geared motor, suitable for inverter drive use. Up to 37 kW these are available with stainless steel motor shroud.
- Pump with geared motor with constant or manually variable speed.
- Pump base plate and coupling guard in stainless steel.
- Lobe rotors suitable for max. 110°C or max.180°C product temperature, in stainless steel 316L or Non Galling Alloy (NGA).
- Piston rotors suitable for max. 110°C product temperature, in stainless steel 316L or NGA.
- Elastomers in EPDM, FPM (Viton) or ISOLAST™.
- Single mechanical shaft seal in SiC/Carbon or SiC/SiC, flushed or non-flushed.
- Double mechanical shaft seal in SiC/Carbon or SiC/SiC .
- Single EPDM lip seal for DW1-5.
- Triple PTFE lip seal (confectionary) for DW1-5.
- Packed gland with sealing thread in PTFE impregnation, for DW1-5.
- Horizontal or vertical suction and discharge ports.
- Rectangular inlet.
- Cooling/heating jacket on rotor case and front cover.
- Pressure relief valves on DW1-5.

Fig. 1



### 1.3 Identifying the pump model

Example - See fig. 1.

ORDER NO: The APV order number of the pump

TYPE: Indicates the type of pump; in this case DW3/017/20  
 \_\_\_\_\_017: displacement volume in l/100 rpm  
 \_\_\_\_\_20: max. allowable differential pressure in bars

SERIAL NO: Indicates the serial number of the pump

YEAR: Indicates year of manufacture

TEMP 110: Max. product temperature in °C.

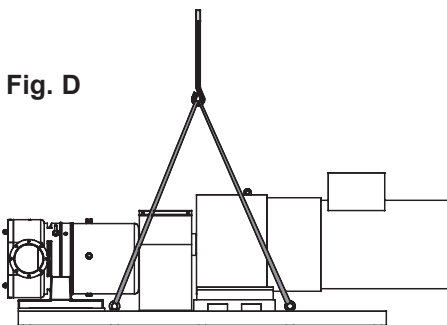
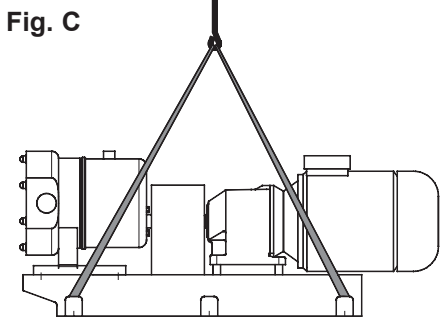
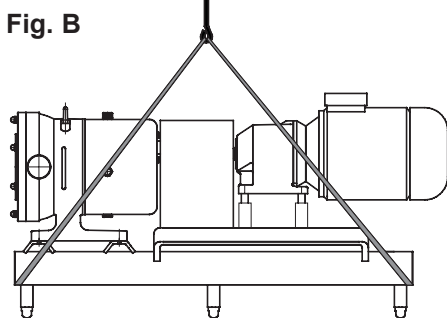
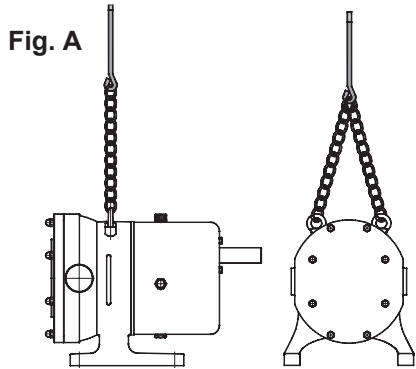
MAX. BAR 20: Max. differential pressure in bars

### 1.4 Identification of motor

The motor is identified by means of the nameplate of the motor.



## 2 Installation of the pump



### 2.1 Handling and storage

Refer to the pump weight in the Spare Parts List page 73 before selecting and using any lifting gear. Ensure that lifting equipment is correctly rated and used within the specified limits.

The drawings on the left shows how the pump should be lifted.

DW1 - DW2 bareshaft pump: To be lifted manually with the hands. Alternately eyebolts can be fitted and the pump lifted as DW3 - DW7. (see fig. A)

DW3 - DW7 bareshaft pump: To be lifted with chain as shown in fig. A.

DW1 - DW5 pump on baseplate type 1: To be lifted by putting straps below the baseplate as shown in fig. B.

Fig. C: DW1 - DW6 pump on baseplate type 2: To be lifted by putting straps below the baseplate as shown in fig. C.

Fig. D: DW6 - DW7 pump on baseplate type 3: To be lifted by putting straps below the baseplate as shown in fig. D.

After receipt and inspection, if the pump is not to be installed immediately, the pump must be repacked and placed in suitable roofed storage. The storage location must be clean, dry and free from vibration.

Plastic or gasket type port covers must be left in place.

If a moist or dusty atmosphere is used for storage, further protect the pump and unit with a suitable cover.

### 2.2 Positioning of the pump

Install the pump as close to the liquid source as possible.

Keep the number of bends, tees, valves and other components in the pipe system leading to the inlet of the pump to an absolute minimum.

Install the pump as low in relation to the liquid source as possible.

Install the pump with sufficient space for maintenance access.

### 2.3 The pipe system

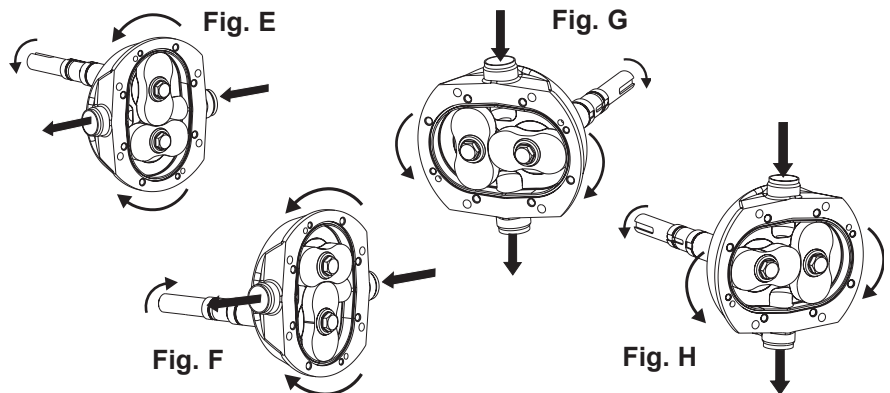
Ensure that pipe unions are properly aligned and assembled.

Use appropriate gaskets.

Support the suction and discharge piping as close to the pump as possible.

### 2.4 Pump rotation

Depending on the required flow direction and the position of the shaft, the rotation direction of the pump is shown on fig. E, F, G and H. The rotation direction can be determined by looking at the motor coupling.



### 2.5 Power supply

Connect the motor to the mains via a motor switchbox in accordance with local regulations. Connect the motor in accordance with the instructions inside the cover of the terminal box of the motor.

Ensure correct pump rotational direction.

## 2 Installation of the pump

### 2.6 Water supply for water flushed seals

If seal flushing is required, connect the flushing liquid to the pump. Pumps fitted with a liquid-flushed mechanical shaft seal have 2 hose connectors for flushing liquids in the seal housing. The hose connectors are M5 and fit a Ø6.0 mm hose. See “Accessories Manual 8.1, Shaft seal” for operating specifications.



*Do not use these connections for flushing with steam or steam condensate. If steam or condensate flush is required, a special aseptic piping must be used.*

## 3. Before start-up and starting the pump

Before starting the pump, remove any dirt, debris or foreign objects which may have collected in the rotor chamber. The rotors should be removed from the pump during the cleaning of the system before start-up. Flushing plugs can be used, see spare part manual. Use the sectional drawing for reference.

### 3.1 Checking the pump for foreign objects:

1. Disconnect the power supply.
2. Undo and remove the front cover bolts (2,3,4) in the front cover (1)
3. Use the two large bolts with full length thread (2) as jacking screws in the threaded holes in the front cover (1). The front cover is removed by turning each bolt one turn at a time - this ensures that the front cover is removed in an even manner. Remove the front cover (1).
4. Rotate the rotors (35) by manually turning the coupling between pump and motor, to ensure that there are no foreign objects behind the rotors.
5. Any foreign objects in the pump, must be removed. Clean with air or water, removing the rotors if necessary. See 4.2
6. Re-fit front cover gasket (5) in rotor case (9).
7. Re-fit the front cover (1) by positioning it on the dowels (7) in the rotor case (9), if fitted, tapping it gently in place with a plastic mallet, and fastening the front cover bolts (2, 3, 4) to the appropriate torque. See section 6.1.
8. Rotate the rotors (35) by manually turning the coupling between pump and geared motor carefully to ensure freedom of movement of the rotors inside the pump.

Fig. 2

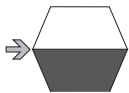
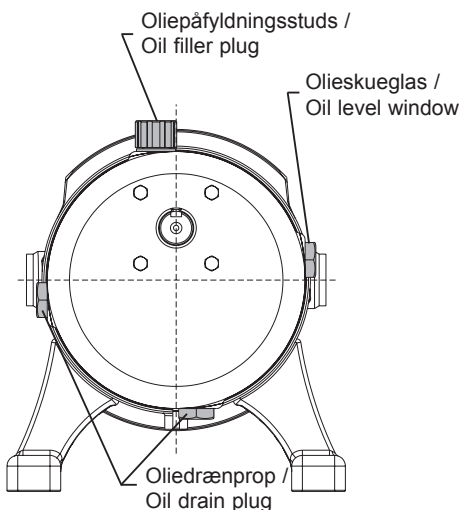


Fig. 19



### 3.2 Check the following before finishing the installation:

- that the oil level of the pump is visible in the oil level window (25) as shown in fig. 2.

**NOTE:**

The oil level window should be mounted on the side that gives the highest oil level. The oil level window is above centreline. See fig. 19.

Pump type	DW1	DW2	DW3	DW4	DW5	DW6	DW7
Lubricant quantities in Litre (ca.)	0.8	1.3	1.4	3	7	25	40

### 3. Before start-up and starting the pump

- that the lubricant used is of an APV recommended type
- that the pump shaft (38) and the motor shaft are properly aligned.
- that the pump port connections are tight.
- that there is liquid in the pump.
- that the pump rotates freely.
- that all suction and discharge valves are open.
- that nothing obstructs the flow and that liquid has free access to the pump.
- that the rotational direction is correct.
- that the coupling guard has been fitted properly.
- if the pump has a flushed seal, check that the flushing flowrate is adequate. See “Accessories Manual 8.1, Shaft seal”.
- that the pump is free from dirt, weld spatter or other foreign objects. See section 3.1.

Standard Lubricants:							
Oil temp. °C	Pump/ambient temp. °C	Lubricant type		BP	Mobil	Shell	Castrol
		Mineral	Synthetic				
-20- +120 °C	Ambient temp. t<40 °C and all DW pumps with product temp.<110 °C	X		Energol GR-XP 220	Mobil gear 630	Omala Oil- 220	Alpha SP 220
120-+180 °C	Ambient temp. t>40 °C and all DW pumps with product temp.>110 °C At oil temperatures higher than 120°C, another drain plug and oil level gauge must be used.		X	Energol SG-XP 220	Mobil Glycole HE460	Tivela Oil WB	Alphasyn T220

Special lubricants for food and pharmaceutical industries:					
Oil temp. °C	Pump/ambient temp. °C	Lubricant type		Type	Approval
		Mineral	Synthetic		
-20- +120 °C	Ambient temp. t<40 °C and all DW pumps with product temp.<110 °C		X	Castrol: Vitalube GS 220	USDA (H1)
			X	Klüber: Klüberoil 4UH- 220	USDA (H1)
			X	Mobil: DTE FM 220	FDA 178.3570 178.362 USDA (H1)a

**APV recommends that the oil be changed every year.**

**NOTE:**

Synthetic and mineral lubricants must not be mixed.

**3.3 Immediately after starting the pump:**

1. Listen for unusual noises.
2. Look for leaks.
3. Check that there is a flow.

### 3. Before start-up and starting the pump

#### 3.4 Fault Finding

Symptoms	Possible causes, see: cause/possible remedies
Motor overheats:	6, 7, 14, 15, 17, 19
Pump under capacity:	2, 7, 8, 9
No flow from pump:	1, 2, 3, 5
Unsteady flow:	2, 4, 5, 7
Noise and vibration:	2, 4, 5, 6, 7, 9, 10, 13, 14, 15, 16, 17, 18, 19, 20
Stall on start-up:	6, 7
Pump overheating:	7, 14, 15, 17, 19
Excessive rotor wear:	4, 10, 13, 14, 15, 18, 19
Excessive power absorbed:	6, 7
Pump seizure:	6, 10, 13, 14, 15, 18, 19
Shaft seal leakage:	11, 12, 13



Cause	Possible remedies
1. Incorrect rotation:	Reverse direction of motor by interchanging 2 of the phaseleads.
2. Insufficient N.P.S.H. and, as a result of this, cavitation:	Increase N.P.S.H., raise suction vessel, lower pump, reduce speed, increase suction pipe diameter, simplify and shorten suction pipe run, remove bends and other components which produce pressure loss.
3. There is no liquid in the pump.	Introduce liquid - vent air.
4. Air entering pump:	Check pump suction and system connections.
5. Blocked or restricted suction pipe:	Check pipe system, clean any filter if necessary.
6. Discharge pressure exceeds the allowable:	Check for obstruction, lower pressure by increasing pipework diameter.
7. Product viscosity too high:	Decrease speed - increase product temperature.
8. Product viscosity too low:	Increase speed - reduce product temperature - reduce clearance between rotor, pump housing and front cover.
9. Worn rotors:	Renew
10. Shaft bearing wear:	Replace bearing or return pump to APV for overhaul, if necessary.
11. Worn mechanical seal:	Renew.
12. O-ring incompatible with product:	Check chemical compatibility chart, or contact APV for alternative elastomers.
13. Worn timing gears:	Replace gears and retime rotors.
14. Insufficient lubricating oil:	Top up with correct grade of lubricant.
15. Incorrect grade of lubricating oil:	Check that the lubricant used is recommended by APV.
16. Rotor contact with rotor case or front cover:	Drop discharge pressure, check clearances between rotors, front cover and pump housing. Check that temperature shifts are as recommended in section 6.4.
17. Pump and motor misalignment:	Correct alignment
18. Foreign objects in product:	Fit strainer.
19. Loose bolts between pump, motor and base frame:	Tighten bolts. Then check that pump and motor are lined up correctly.
20. Loose bolts between gearcase and foot:	Tighten bolts. Then check that pump and motor are lined up correctly.

## 4. Dismantling and re-assembling the pump

There are a few basic operations to carry out during maintenance of the pump. These are described in the following sections. The sectional drawing shows the position of the various components mentioned in this procedure.

### 4.1 Remove front cover (1):

To remove and re-fit the front cover (1) it is necessary to follow the procedure as described below. Use the sectional drawing for reference (page 2).

1. Disconnect the power supply to the motor.
2. Shut off the flushing supply, if fitted.
3. Close the isolating valves on the inlet and discharge side of the pump.
4. Undo the front cover bolts (2,3,4). If the pump is used for hot and/or aggressive liquids, special precautions must be taken. In such cases, observe the local regulations for personal protection when working with these products.
5. Use the two large bolts with full length thread (2) as jacking screws in the threaded holes in the front cover (1). The front cover is removed by turning each bolt one turn at a time - this ensures that the front cover is removed the rotor case (9) in an even manner. Remove the front cover (1).

#### 4.1.1 Re-fit of the front cover:

1. Re-fit front cover gasket (5) in rotor case (9).
2. Re-fit the front cover (1) by positioning it on the dowels, if any, (7) located in the rotor case (9), tapping it gently in place with a plastic mallet, and fastening the front cover bolts (2, 3, 4) to the appropriate torque. See section 6.1.
3. Rotate the rotors (35) by manually turning the coupling between pump and geared motor carefully to ensure freedom of movement of the rotors inside the pump.

Rotor locking piece

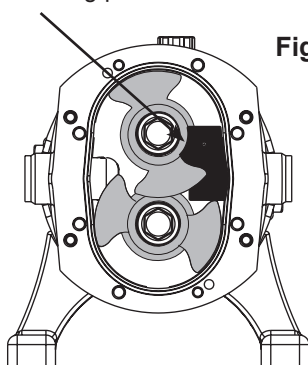


Fig. 3

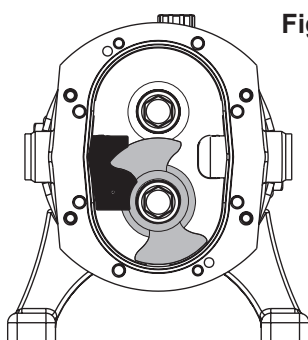


Fig. 4

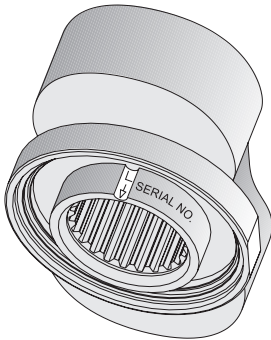
### 4.2 Remove the rotors (35)

To remove and re-fit the rotors it is necessary to dismantle the pump as described below. Use the sectional drawing for reference (page 2).

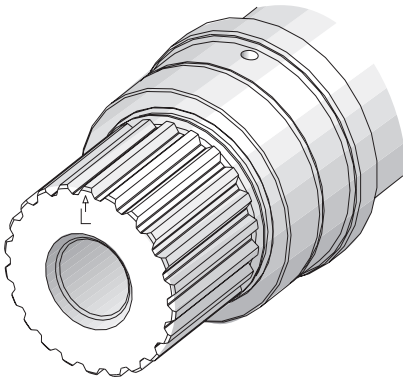
1. Remove the front cover (1) as described in section 4.1.
2. Position the rotors (35) and insert the fitting tool as shown in fig. 3.
3. Undo and remove the top or right rotor screw (32).
4. Remove the rotor locking piece and pull the rotor (35) out from the shaft (38). Ensure that the wings of the other rotor are not overlapping the hub of the rotor being pulled out.
5. Notice the marking of the rotors as shown in fig. 5. The rotors are marked with respectively 'L' for the main (long) and 'S' for the aux. (short) shaft. Notice that the rotors are marked on the back with the serial number.
6. Position the rotor locking piece as shown in fig. 4.
7. Undo and remove the bottom or left rotor screw (32).
8. Remove the rotor (35) as before by pulling it out from the shaft (39) with your fingers / special extractor.

## 4. Dismantling and re-assembling the pump

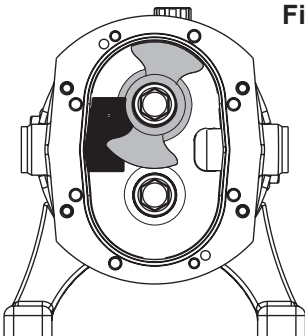
**Fig. 5**



**Fig. 6**

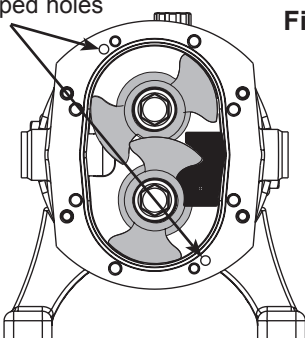


**Fig. 7**



Tapped holes

**Fig. 8**



### 4.2.1 Re-fit the rotors (35)

Check the contact surfaces (B, D) of the shaft seal for debris and scratches. Use the section drawing for shaft sealing as reference (page 5).

1. For re-fitting the rotors use the sectional drawing for reference (page 2). Check on DW1-5 that the rotor marked with 'L' is mounted on the main (long) shaft (38) and the rotor marked with 'S' is mounted on the aux. (short) shaft (39). See fig. 5. Notice that the rotors are marked on the back with the serial number. On both DW6 and DW7 shafts and rotors are marked with 'L' and 'S' respectively - see fig. 5 and 6. Furthermore they are marked with an arrow against the 'L' and 'S'. At assembly the arrow on the rotor and shaft must be aligned. It is important that shims are placed in the same position as before dismantling.
2. Re-fit top or right rotor (35) on the shaft (38).
3. Position the rotor (35) and the rotor locking piece as shown in fig. 7 and tighten the screw (32) to the specified torque - see section 6.1. Remove rotor locking piece.
4. Re-fit bottom or left rotor (35) on the shaft (39).
5. Position the rotor (35) and the rotor locking piece as shown in fig. 8 and tighten the screw (32) to the specified torque - see section 6.1. Remove rotor lock.
6. Rotate the rotors (35) by manually turning the coupling between pump and geared motor carefully to ensure freedom of movement of the rotors inside the pump.
7. Carry out shimming procedure as described in sections 4.9 and 4.9.1.

### 4.3 Remove the rotor case (9)

To remove and re-fit the rotor case (9) it is necessary to dismantle the pump as described below. Use the sectional drawing for reference (page 2).

1. Remove front cover (1) as described in section 4.1.
2. Remove rotors (35) as described in section 4.2.
3. Remove stationary seal rings (D), and seal O-rings (C) with your fingers.
4. Disconnect the inlet and outlet ports of the pump from the surrounding pipework.
5. Undo the bolts (6) that attach the rotor case (9) to the chassis (13).
6. Remove the rotor case (9) by placing the bolts (6) into the two tapped holes and turn each bolt one turn at a time.

#### 4.3.1 Re-fit the rotor case (9)

1. Position the rotor case (9) on the dowels mounted in the chassis (13) and use a plastic mallet to tap the rotor case home.
2. Re-fit and tighten the bolts (6) between the rotor case (9) and the chassis (13) to the specified torque. See section 6.1.
3. Position the O-rings (C) on the shaft seal's stationary seal ring (D) and press the stator seal rings (the longer of the seal rings) into the rotor case (9) without using tools. Keyways in the stationary seal faces (D) must fit over drive dogs of the drive ring (G) in the rotor case (9). Check correct mounting of the stationary seal faces by feeling the spring force when mounting them in the rotor case (9).

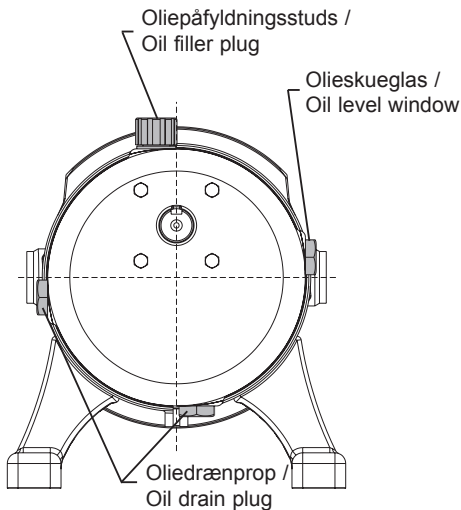
## 4. Dismantling and re-assembling the pump

### 4.4 Remove can (26)

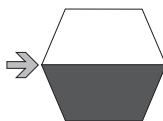
To remove and re-fit the can (26) it is necessary to dismantle the pump as described below. Use the sectional drawing for reference (page 2).

1. Disconnect the power supply.
2. Disconnect the pump from the geared motor. If possible, remove the pump from the pipework and put it on a work bench.
3. Drain the oil from the pump by undoing the oil drain plug (27) situated in the bottom of the can (26).
4. Remove drive key (43).
5. Remove the clamp ring (18).
6. Remove the can (26).

**Fig. 19**



**Fig. 2**



#### 4.4.1 Re-fit can (26)

1. Check correct mounting of the O-ring (17).
2. Refit the can (26) over the shaft (38). Tighten the clamp ring (18) to the specified torque. See section 6.1.
3. Refit the oil level window (25), see fig. 19.
4. Fill the gearbox with the recommended oil to the specified level according to fig.2. Check for leaks. See section 3.2 for required oil amount.

### 4.5 Remove lipseal holder (20)

1. Remove can support (26) as described in section 4.4.
2. Remove screws (24)

#### 4.5.1 Re-fit lipseal holder (20)

1. Check correct mounting of O-ring (21) and lipseal (22).
2. Mount screws (24) loosely.
3. Mount the can (26) as described in section 4.4.1.
4. Tighten the screws (24) for the lipseal holder (20) to the specified torque - see section 6.1.

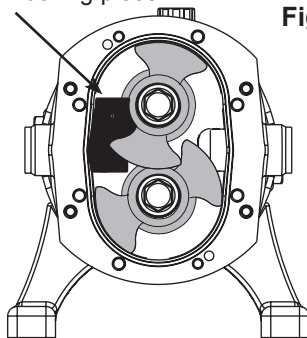
### 4.6 Remove the timing gears (54)

To remove and re-fit the timing gears (54) it is necessary to dismantle the pump as described below. Use the sectional drawing for reference (page 2).

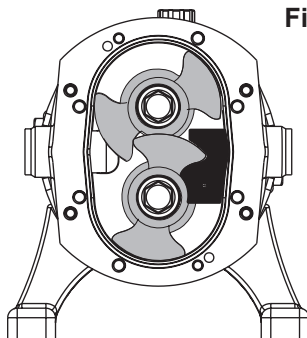
1. Remove can (26) as described in section 4.4.
2. Remove front cover (1) as described in section 4.1.
3. Position the rotors (35) and insert the rotor locking piece as shown in fig. 9.
4. Straighten the locking tab on the washer of the gear nut (55) at the gears (54) and undo the upper or right gear nut (56).
5. Re-position the rotor lock as shown in fig. 8.

Rotor locking piece

**Fig. 9**

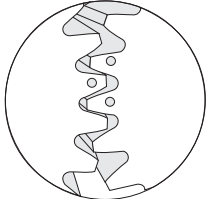


**Fig. 8**



## 4. Dismantling and re-assembling the pump

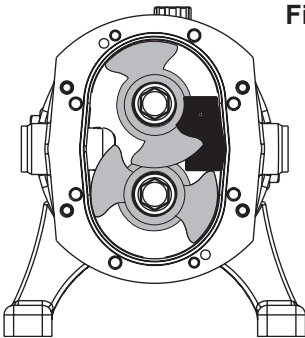
**Fig. 10**



6. Undo the bottom or left gear nut (56).
7. Remove rotor lock and rotors (35) as described in section 4.2.
8. Straighten the locking tab on the washer (55) at the gears (54) and remove the washers (55).
9. Pull the gears (54) off the shafts (38, 39) using an extractor. Note by means of centre-punch marks which gear came off which shaft.

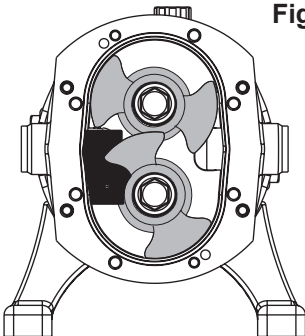
### 4.6.1 Re-fit the timing gears (54)

**Fig. 3**



1. Refit the timing gears (54) onto the shafts (38, 39). Check that the correct gear is fitted onto the correct shaft and correct positioning of the gears as per fig. 10.
2. Position rotors (35) as described in section 4.2.1.
3. Position rotor locking piece as shown in fig. 3.
4. Position washer (55) and gear nut (56) onto the drive shaft (38) and tighten the gear nut to the specified torque. See section 6.1.

**Fig. 11**



5. Position rotor locking piece as shown in fig. 11.
6. Refit washer (55) and gear nut (56) onto the auxiliary shaft (39) and tighten the gear nut to the specified torque - see section 6.1.
7. Bend the locking tabs on the tab washers (55).

### 4.7 Remove the oil seal plate (10)

To remove and re-fit the oil seal plate (10) it is necessary to dismantle the pump as described below. Use the sectional drawing for reference (page 2).

1. Remove the front cover (1) as described in section 4.1.
2. Remove the rotors (35) as described in section 4.2.
3. Remove the rotor case (9) as described in section 4.3.
4. Remove can (26) as described in section 4.4.
5. Remove the oil seal plate (10) by undoing and removing the nuts (28) and pulling the front oil seal plate out.

#### 4.7.1 Re-fit the oil seal plate (10)

1. Refit the oil seal plate (10) on to the shafts and tighten the nuts (28) to the specified torque. See section 6.1.  
Ensure that the O-rings (11) and lipseals (42) are placed in the oil seal plate (10) before refitting.

### 4.8 Remove the foot (29, 30)

1. Undo and remove the screws (31). Use a hexagon socket wrench.

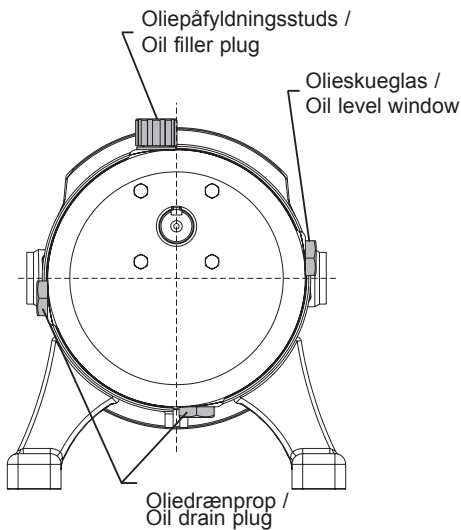
#### 4.8.1 Re-fit the foot (29, 30)

1. Mount the screws (31). Use Loctite 242. Use a hexagon socket screw wrench.
2. Align the assembly holes with the baseplate holes.
3. Tighten the screws (31) to the specified torque. See section 6.1.



## 4. Dismantling and re-assembling the pump

**Fig. 19**



If the position of the feet and hence in- and outlet is changed, it is necessary to change the position of the oil filler plug, the oil level window etc. as shown in fig. 19.

**NOTE:**

Mount the plug (14) flush with the surface. Use Loctite 242.

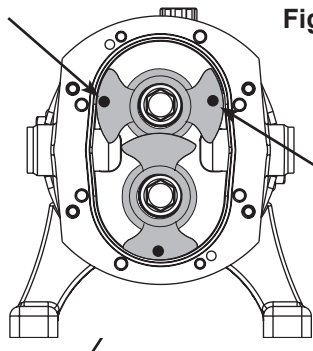
### 4.9 Adjustment of the rotors axial position

To be able to operate the pump effectively and safely, it is necessary to carry out the adjustment of the rotors axial position after having dismantled and re-assembled the pump to ensure the correct axial position of the two rotors. Use the sectional drawing for reference (page 2).

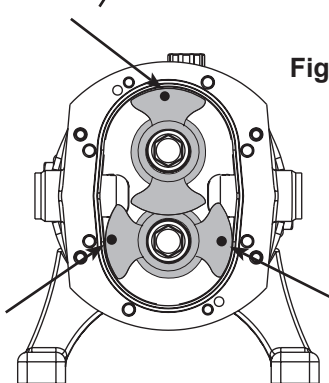
The measured clearance should be as close to the clearances described in section 6.8 as possible.

1. Measure the difference in depth between rotors (35) and rotor case (9) by means of a depth micrometer. The points at which you should measure the depths are shown in fig. 12 and 13. Then the rotors are turned 180° and measured again. So that twelve measurements are made in total.
2. Measure the rear clearance by means of feeler gauges. See fig. 14. Never go below the min. clearance stated in section 6.8. The rear clearance should be measured at the same points as stated in section 4.9 item 1.
3. Measure the radial clearance between rotor (35) and rotor casing (9) by means of feeler gauges. The clearance should be measured at the same rotor positions as stated in section 4.9 item 1.
4. If the clearances are not within the limits stated in section 6.8 or if the distances measured are not able to be made closer to the mean values stated in section 6.8, the rotors (35) are removed as stated in section 4.2.
5. Remove the O-rings (36) situated on the shafts (38,39).
6. Remove the shims (37) of the shaft (38,39), measure the total thickness of the shims with a micrometer, and add or subtract the required amount of clearance to the shim thickness (e.g. if front clearance is 0.1 mm too large, 0.1 mm must be added to the total thickness of shims).
7. Refit shims (37) to the shafts (38,39). The thinner shims must be inserted first.
8. Refit O-rings (36) on the shafts.
9. Refit rotors (35) as described in section 4.2.1.
10. Measure front and rear clearance again. If the clearances are still outside the limits, or if they can come closer to the mean values stated in section 6.8, repeat shimming procedure until the measured clearances are correct.
11. When the front and rear clearances are correct, check that the rotors (35) turn freely.

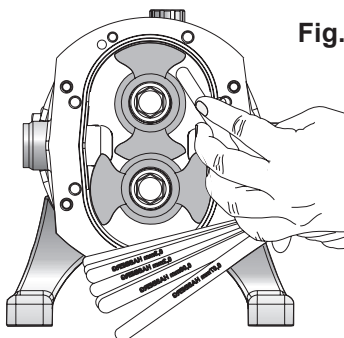
**Fig. 12**



**Fig. 13**



**Fig. 14**



## 4. Dismantling and re-assembling the pump

### 4.9.1 Adjustment of the rotors angular position

To run the pump effectively and safely, it may be necessary to carry out the adjustment of the rotors angular position after dismantling and re-assembling it, to ensure the correct angular position of the two rotors. Use the sectional drawing for reference (page 2).

**NOTE:**

Re-timing applies to lobe rotors only.

Re-timing is carried out as described below:

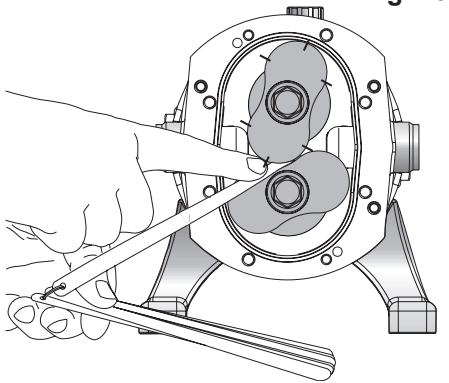


Fig. 15

1. Measure the interlobe clearances with feeler gauges at the 6 positions as shown in fig. 15. If these clearances are outside the tolerances stated in section 6.8. (column "Interlobe"), it is necessary to re-time the rotors.
2. Remove can (26) as described in section 4.4.
3. Choose one of the shafts to work on. Straighten the locking tab on the washer (55) and loosen the gear nut (56). (use e.g. a wedge shaped object of soft material e.g. wood, plastic or nylon wedged between the two wheels.) Ease the gear (54) max. 1 mm back along the shaft (it is important not to move the gear more than the 1 mm as it can cause damage to the rotors themselves).
4. Re-check the clearances and see if the rotors have shifted in the correct direction according to section 6.8. If the rotors have shifted in the correct direction as wanted go to section 4.9.1 item 6.
5. If the rotors have **not** shifted in the correct direction, retighten the gear nut (56) to the specified torque as described in section 6.1 and bend the tab washer down again (55). Return to section 4.9.1 item 3, but work on the other shaft.
6. Ease the second gear back along the shaft until the clearance between the rotors are as described in section 6.8.
7. The new distance between the spacer (52) and the moved gear (54) is measured with feeler gauges. Shims (53) with the total thickness corresponding to the distance measured are selected.
8. Remove the gear (54) and gear key (40) as described in section 4.6 from the shaft and fit the selected shims (53) on the shaft.
9. Re-fit gear key (40) and gear (54) as described in section 4.6.1. Re-fit tab washer (55) and gear nut (56) and tighten it to the specified torque as described in section 6.1.
10. Measure the interlobe clearances. If they are still not within the tolerances stated in section 6.8 repeat the procedure starting from section 4.9.1 item 3.
11. Check that the rotors turn freely.
12. Refit the can (26) as described in section 4.4.1

---

## 5. Maintenance

---

### 5.1 Replacing rotors

The rotors of the pump can be replaced with new rotors of the same type and dimension.

It is also possible to change from piston rotor to bi-lobe rotor and vice versa on the following pump types:

DW1/003/7.5 ⇔ DW1/004/15

DW2/006/10 ⇔ DW2/007/20

DW3/014/10 ⇔ DW3/017/20

DW4/033/10 ⇔ DW4/039/20

DW5/080/12.5 ⇔ DW5/093/25

To change rotors it is necessary to dismantle the pump as described below. Use the sectional drawing for reference (page 2).

1. Remove the front cover (1) as described in section 4.1.
2. Remove the rotors (35) as described in section 4.2.
3. Ensure that stationary seal rings (D) are correctly in place in the rotor case and free from debris and scratches.
4. Ensure that rotary seal rings (B) are mounted correctly in the new rotors (35) and free from debris and scratches.
5. Refit rotors (35) as described in section 4.2.1.
6. Carry out the shimming procedure as described in section 4.9.

*For piston rotor to piston rotor and bi-lobe rotor to piston rotor:*

7. If no dowels (7) are fitted in the rotor case (9), fit the dowels in the dowel holes in the front of the rotor case (9).
8. Tap the dowels (7) gently in place with a plastic mallet.
9. Re-fit the front cover (1) for piston rotors as described in section 4.1.1.
10. Check that the pump turns freely.

*For bi-lobe rotor to bi-lobe rotor or piston rotor to bi-lobe rotor:*

7. Carry out re-timing procedure as described in section 4.9.1.
8. Check that the rotors (35) turn freely.
9. If dowels (7) are situated in the rotor case (9), remove them.
10. Refit the front cover (1) for bi-lobe rotors as described in section 4.1.1.
11. Check that the rotors (35) turn freely.

## 5. Maintenance

### 5.2 Replacement of single mechanical shaft seals

To change shaft seal it is necessary to disassemble the pump as de-scribed in the following. Use the sectional drawing for reference (page 2 and 5).

1. Remove the front cover (1) as described in Section 4.1.
2. Remove the rotors (35) as described in Section 4.2.
3. Remove the stationary seal face (D) and the O-ring (C) with the fingers
4. Check the new shaft seals contact surface for dirt and scratches.
5. Mount the new stationary seal face (D) and O-ring (C) in the rotor casing (9) without using tools. The stationary seal face (D) is the longer of the two shaft seal rings. The keyway in the stationary seal face (D) must fit over the groove in the stationary drive ring (G). Check that it is correctly fitted by feeling the spring force (H) when it is pushed in over the shaft (38,39).
6. Remove the rotary seal face (B) and O-ring (C) from the rotor (35).
7. Insert a new rotary seal face (B) and O-ring (C) in the rotor (35).
8. Mount the rotors (35) as described in Section 4.2.1.
9. Mount the front cover (1) as described in Section 4.1.1.
10. Check that the rotors turn freely.

#### NOTE:

All types of shaft seal (single lip seal, triple lip seal, single mechanical seal, single mechanical seal with water flush, dual mechanical seal and packed gland packing ) can all be mounted on the same pump. This requires only the correct shaft seal kit. These kits are described in the additional manual for shaft seals, "Accessories Manual 8.1, Shaft seal".

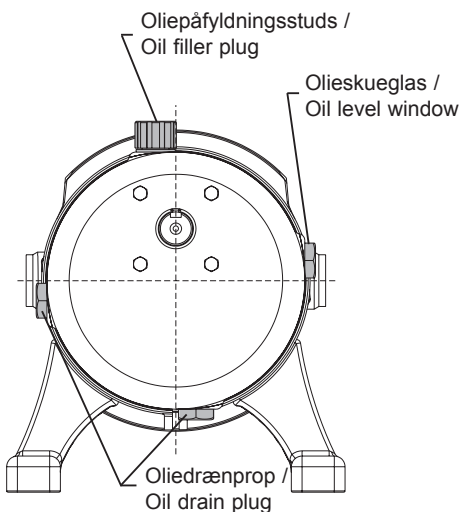
### 5.3 Changing port orientation

It is possible to change the suction and discharge port orientation from horizontal to vertical and vice versa without making any modifications to the pump.

To change the port orientation it is necessary to dismantle the pump as described below. Use the sectional drawing for reference (page 2).

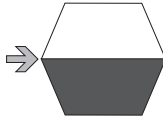
1. Disconnect the power supply to the motor.
2. Disconnect the pump from the motor. If possible, remove the pump from the pipework and place it on a work bench.
3. Undo the oil drain plug (27) in the bottom of the can (26) to drain the oil from the pump.
4. Exchange the plugs on the can (26). Orange oil filler plug (23) in top position. The oil level window should be mounted on the side that gives the highest oil level - oil level window (25) above the centreline. Oil drain plugs (27) at the bottom and the side below the centreline, see fig. 19.

**Fig. 19**



## 5. Maintenance

**Fig. 2**

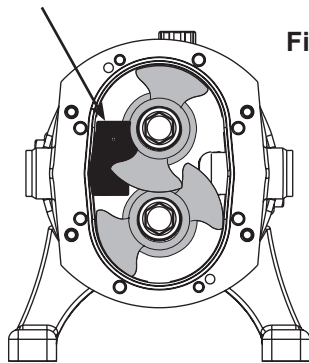


5. Move the feet (29, 30) to the required position as described in sections 4.8 and 4.8.1.
6. Fill the gearbox with oil to the specified level according to fig. 2. Check for leaks. See section 3.2 for required amount of oil and positioning of oil level window.

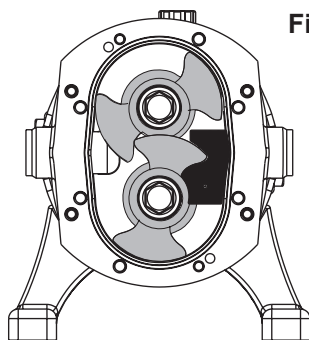
### 5.4 Changing the bearings (45, 48)

To replace the bearings (45,45a,45b,48,48a,48b) it is necessary to dismantle the pump as described below. Use the sectional drawing for reference (page 2).

Rotor locking piece



**Fig. 9**



**Fig. 8**

1. Remove the timing gears (54) as described in section 4.6
2. Remove gear key (40), shims (53), spacer (52) and circlip (51).
3. Straighten the locking tab on the tabwasher (49).
4. Position the rotor locking piece as shown in fig. 9, and undo the drive shaft (38) bearing lock nut (50).
5. Reposition the rotor locking piece as shown in fig. 8.
6. Undo the auxiliary shaft (39) bearing lock nut (50).
7. Remove bearing nut (50) and tabwasher (49).
8. Remove the rotors (35) as described in section 4.2.
9. Remove the shims (if fitted) and shaft O-ring. Keep the shims and O-ring together as a set for each shaft. Mark each set for identification to ensure later re-assembly on the correct shaft.
10. Remove rotor case (9) and the oil seal plate as described in sections 4.3 and 4.7.
11. Remove shafts (38, 39) from the chassis (13) by applying force to the rear of the shafts. During this process, the bearings should be pushed free. Remove the shaft and bearings.
12. Remove outer bearing races (45b,48b) from the chassis and inner bearing races (45a,48a) from the shafts (38,39). If the shafts are damaged they should be replaced.
13. Clean the bearing seats of the chassis (13) and the shafts (38,39).
14. Fit new outer bearing races (45b,48b) and spacing washer (47) in the chassis(13).
15. Fit the front inner bearing race (45a) on the shafts (38,39) by heating the bearings.
16. Place both shafts (38,39) in the bore hole of the chassis.
17. Fit rear inner bearing race (48a), washer (49) and bearing lock nut (50) on to the shafts (38,39).
18. Position the shims (44) and fit the oil seal plate (10), but without lipseals (42).
19. Fit the rotor case (9) as described in section 4.3.1.
20. Fit the rotors (35) onto the shafts (38,39) (without- the shaft seal) as described in section 4.2.1.

## 5. Maintenance

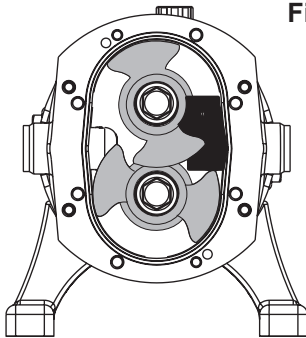


Fig. 3

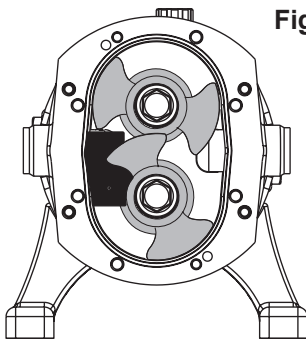


Fig. 11

21. Position the rotor locking piece in fig. 3 and 11, respectively, and tighten the bearing lock nuts (50) until no backlash can be felt in the bearing assembly.
22. Remove the rotors (35) from the shafts as described in section 4.2.
23. Check that the shafts (38,39) turn freely.
24. Check that the running torque of both drive shaft (38) and auxiliary shaft (39) is as specified in the table in section 6.1. Measure the relevant torque without lipseals. During the measuring the bearings must be lubricated with WD40. Check that the shafts can run freely.
25. If the torque is not within the specification given in section 6.1 then adjust the nuts (50) and repeat the procedure until the correct torque is obtained.
26. Bend the locking tab on the washer (49).
27. Refit circlip (51), spacing ring (52) and gear key (40) on the shafts (38,39).
28. Refit the gears (54) as described in section 4.6.1.
29. Fit the oil seal plate (10) with lipseals (42) as described in section 4.7.1 and the rotor case (9) as described in section 4.3.1.
30. Fit rotors (35) as described in section 4.2.1. Check that the stationary seal faces (D), and O-rings (C) are in place in the rotor case (9). Check seals (B,D) for debris and scratches.
31. Re-fit the can (26) as described in section 4.4.1.
32. Re-fit the front cover (1) as described in section 4.1.1.
33. Ensure that the rotors turn freely.

### 5.5 Recommended holding of spare parts

We recommend that both seal kits and service kits are held in stock.

#### Seal Kit

The seal kit consists of the wearing parts of the seal.

#### Service Kit

The service kit is made up of a number of the main components of the pump. These components are not wearing parts, but replacement may be necessary. These components are rotors (35), front cover (1), rotor case (9), rotor screws (32), spacing washers (37), shafts (38,39), bearings (45,48), gears (54), and gear shims (53).

The table below shows the recommended stock of spare parts for normal operation, and for applications where there are special requirements - for example 24 hour operation, operation with abrasive me-dia, or processes which are sensitive to even a short production stop.

	WEARING PARTS (Seal face kit, Elastomer kit)			SERVICE PARTS		
	Number of pumps in operation			Number of pumps in operation		
	0-5	5-20	>20	0-5	5-20	>20
	Kits	Kits	Kits/10 pumps in oper.	Kits	Kits	Kits/10 pumps in oper.
Normal operation	1	2	1	0	1	1
Special requirements	2	3	2	1	2	1

## 6. Technical data

### 6.1 Tightening Torque Settings

Tightening torque required for bolts, nuts, and screws in the DW pumps:

Metric tool must be used - size shown in [mm]

	Front cover bolts/nuts. Large	Front cover bolts. Small	Rotor bolts	Rotor case/chassis. Bolts	Seal housing. Screws	Oilseal plate. Nut	Chassis/foot. Screws	Running torque, bearings, approx. 100 rpm. Shaft	Clamp ring. Screw	Gear nut	Lipseal holder. Screws
Pos no.	(2)	(3)	(32)	(6)	(1)	(28)	(31)		(19)	(56)	(24)
Pump	Nm	Nm	Nm	Nm	Nm	Nm	Nm	Nm	Nm	Nm	Nm
DW1	10 [13]	10 [13]	10 [13]	10 [10]	10 [10]	10 [10]	30 [6 UMB]	0.8-1.0 [SKF-HN05]	10 [ UMB]	25 [SKF-HN04]	10 [10]
DW2	10 [13]	10 [13]	40 [19]	10 [10]	10 [10]	20 [13]	30 [6 UMB]	1.5-1.75 [SKF-HN06]	10 [5 UMB]	50 [SKF-HN05]	10 [10]
DW3	20 [17]	20 [17]	70 [22]	20 [13]	10 [10]	20 [13]	30 [6 UMB]	2.0-2.5 [SKF-HN07]	10 [5 UMB]	75 [SKF-HN06]	10 [10]
DW4	20 [17]	20 [17]	220 [30]	40 [17]	20 [13]	40 [17]	55 [8 UMB]	4.1-5.0 [SKF-HN09]	10 [5 UMB]	100 [SKF-HN08]	20 [13]
DW5	30 [19]	30 [19]	570 [36]	60 [19]	20 [13]	40 [19]	95 [10 UMB]	4.2-5.0 [SKF-HN10]	10 [5 UMB]	125 [SKF-HN09]	20 [13]
DW6(piston)	190 [24]	190 [24]	400 [46]	400 [30]	20 [6 UMB]	60 [19]	190 [24]	14.0-16.0 [SKF-HN13]	10 [5 UMB]	150 [SKF-HN12]	20 [13]
DW6(lobe)	190 [24]	190 [24]	1000 [46]	400 [30]	20 [6 UMB]	60 [19]	190 [ 24]	14.0-16.0 [SKF-HN13]	10 [5 UMB]	150 [SKF-HN12]	20 [13]
DW7(piston)	400 [30]	400 [30]	600 [55]	400 [30]	40 [8 UMB]	60 [19]	380 [30]	15.0-17.0 [SKF-HN17]	10 [5 UMB]	300 [SKF-HN15]	40 [17]
DW7(lobe)	400 [30]	400 [30]	1900 [55]	400 [30]	40 [8 UMB]	60 [19]	380 [30]	15.0-17.0 [SKF-HN17]	10 [5 UMB]	400 [SKF-HN15]	40 [17]

## 6. Technical data

### 6.2 Maximum differential and discharge pressures

The maximum differential pressures and discharge pressure specified below must not be exceeded.

	Differential pressure
Max. 30 bar:	DW6/198/30; DW7/420/30
Max. 25 bar:	DW5/093/25
Max. 20 bar:	DW2/007/20; DW3/017/20; DW4/039/20
Max. 15 bar:	DW1/004/15; DW1/007/15_600; DW2/013/15_600; DW3/030/15_600; DW4/073/15_600; DW5/142/15; DW6/308/15; DW7/725/15
Max. 12.5 bar:	DW5/080/12.5; DW6/172/12.5
Max. 10 bar:	DW2/006/10; DW2/013/10; DW3/014/10; DW3/030/10; DW4/033/10; DW4/073/10; DW7/370/10
Max. 7.5 bar:	DW1/003/7.5
Max. 7 bar:	DW1/007/7; DW4/125/7_600; DW5/256/7; DW6/519/7; DW7/1016/7
Max. 5 bar:	DW3/050/5; DW4/125/5

	Discharge pressure
Max. 33 bar	DW6; DW7
Max. 28 bar	DW5
Max. 23 bar	DW2; DW3; DW4
Max. 18 bar	DW1

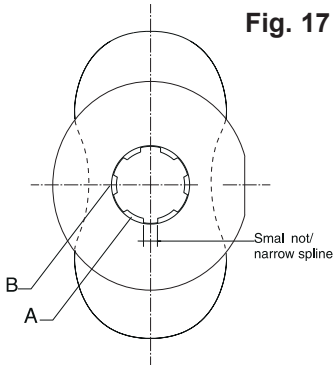


Fig. 17

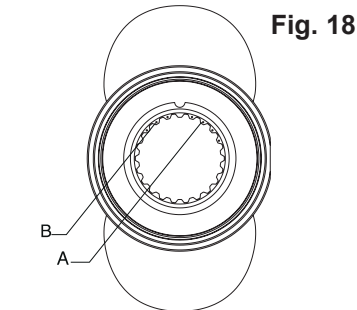


Fig. 18

- A** = Rotor type  
 · = High efficiency (110°C); NGA High Efficiency  
 .. = High temperature\* (180°C); NGA High temperature  
 ... = Multi-Duty (110°C)  
 .... = Super tight\* (110°C)
- B** = Material  
 · = Stainless steel  
 .. = Non Galling Material (NGA)  
 ... = Special Material

### 6.3 Maximum permissible moment

For motors of 45kW capacity onward it is recommended, due to the inertia of the motor, to equip the coupling between the pump and gearmotor with a safety device ensuring that the maximum transferred moment does not exceed the pump's maximum allowable moment given in the table below.

	DW1	DW2	DW3	DW4	DW5	DW6	DW7
Max. moment	35Nm	60Nm	140Nm	250Nm	700Nm	1400Nm	2800Nm

The coupling supplier's demands for lining up must be kept.

### 6.4 Maximum permissible temperature

Check the nameplate of the pump to see the maximum permissible temperature limit for the pump. This temperature must not be exceeded.

Furthermore, the maximum rotor temperature should be checked. Rotors with maximum temperature of 110°C are marked with · or ... or .... on the spline. Rotors with maximum temperature of 180°C are marked with .. on the spline. See fig. 17 for DW1-5 and fig. 18 for DW6&7 and the description under the illustrations on the left.

### 6.5 Sound Pressure and Sound Power Level

Measurements have been carried out in accordance with:  
 DS/ISO 3744 grade 2, class 2 for DW1  
 DS/ISO 9614-2 for DW2-7

Tolerance ±3dB.

\* Contact the factory for clearances not specified in section 6.8.



## 6. Technical data

LpA in dB refers to the sound pressure level at a distance of 1 metre from the surface of the pump at a height of 1.6 m above floor level, as required by EC Directive (98/37/EEC).

Lwa states the sound power level.

The sound power levels have been stated for the following operating conditions:

- A:** Maximum differential pressure and maximum rotational speed
- B:** Maximum differential pressure and 50% of maximum rotational speed
- C:** Maximum differential pressure and 25% of maximum rotational speed
- D:** 50% of maximum differential pressure and maximum rotational speed
- E:** 50% of maximum differential pressure and 50% of maximum rotational speed
- F:** 50% of maximum differential pressure and 25% of maximum rotational speed

The values shown in the table apply to water at 20°C.

The noise level may increase considerably, if reducers (reduction/expanding fittings) are mounted on the inlet/outlet.

Pump	LpA in dB						LwA in dB					
	A	B	C	D	E	F	A	B	C	D	E	F
DW1/003/7.5	62	56	46	60	53	46	75	69	61	72	65	60
DW1/004/15	63	57	47	59	52	45	75	69	61	72	65	60
DW1/007/7	64	58	48	62	55	48	76	70	62	74	67	61
DW1/007/15_600	59	53	43	57	50	43	69	63	54	67	60	54
DW2/006/10	64	58	48	62	55	48	76	70	62	74	67	61
DW2/007/20	65	59	49	65	58	51	76	70	62	76	69	63
DW2/013/10	67	61	51	67	60	53	78	72	64	78	71	65
DW2/013/15_600	62	56	46	60	53	46	70	64	55	69	62	56
DW3/014/10	72	66	56	70	63	56	83	77	68	81	73	67
DW3/017/20	74	68	58	70	62	55	85	79	70	81	73	67
DW3/030/10	74	68	58	72	65	58	85	79	70	83	76	70
DW3/030/15_600	70	58	52	66	58	52	82	70	64	78	70	64
DW3/050/5	75	69	59	73	66	59	86	80	71	84	77	71
DW4/033/10	75	65	62	67	62	59	86	76	73	78	73	70
DW4/039/20	77	67	63	69	64	61	88	78	74	80	75	72
DW4/073/10	78	68	64	70	65	62	89	79	75	81	76	73
DW4/073/15_600	71	65	62	67	63	61	83	77	74	79	75	73
DW4/125/5	79	69	65	71	66	63	90	80	76	82	77	74
DW4/125/7_600	77	67	63	69	64	61	88	78	74	80	75	72
DW5/080/12.5	80	72	68	78	71	67	91	83	79	89	82	78
DW5/093/25	82	74	70	80	73	69	93	85	81	91	84	80
DW5/142/15	81	73	69	79	72	68	92	84	80	90	83	78
DW5/256/7	83	75	71	81	74	70	94	86	82	92	85	81
DW6/175/12.5	76	72	70	73	71	70	88	84	82	85	83	82
DW6/198/30	86	77	73	78	73	71	98	89	85	90	85	83
DW6/308/15	84	77	71	78	70	70	96	89	83	90	82	82
DW6/519/7	80	73	71	80	70	70	92	85	83	92	82	82
DW7/370/10	84	76	72	76	72	70	96	88	84	88	84	82
DW7/420/30	93	81	75	82	75	72	105	93	87	94	87	84
DW7/725/15	92	80	74	81	75	72	104	92	86	93	87	84
DW7/1016/7	88	76	74	85	71	72	100	88	86	97	83	84

## 6. Technical data

### 6.6 Temperature changes and max. temperature:

The following precautions should be observed regarding product temperature changes in the pump.

#### High efficiency and Super tight (NGA) rotors:

Pumps fitted with high efficiency or Super tight rotors should be treated with caution when the product temperature changes.

#### Multi-duty rotors:

Pumps fitted with multi-duty rotors are designed to withstand an immediate product temperature change corresponding to a CIP cleaning regime.

#### High temperature rotors:

Pumps fitted with High temperature rotors are designed to withstand an immediate product temperature change corresponding to a SIP procedure.

#### SIP:

The pumps with High efficiency, Super tight or Multi-Duty rotors are stationary (not running) prior to SIP.

The permissible product temperatures and their permissible changes can be found in the table below:

Rotor type	Material	Max product temperature	Max ΔT
Super tight	NGA	180°C	80°C
High efficiency	NGA	180°C	80°C
High efficiency	316L	110°C	50°C
Multi-Duty	316L	130°C	110°C
High temperature	NGA	210°C	180°C
High temperature	316L	180°C	120°C

At temperature changes above max ΔT the product temperature should be increased gradually, according to the formula below:

$$\frac{\text{Required } \Delta T - \text{Max } \Delta T}{2.1^{\circ}\text{C}} \times 5 \text{ sec.} = \text{TIME in sec.}$$

In case of increased temperature changes we recommend using electronic control.

### 6.7 Maximum permissible rotational speed

The maximum rotational speed specified below must not be exceeded.

DW1: max. 1400 rpm  
 DW2: max. 1400 rpm  
 DW3: max. 1400 rpm  
 DW4: max. 1200 rpm  
 DW5: max. 1000 rpm  
 DW6: max. 800 rpm  
 DW7: max. 600 rpm  
 DW1 - 4/xxx\_600: max. 600 rpm

## 6. Technical data

DW1

### 6.8 Clearance for adjustment of pumps

#### DW1/003/7.5 - Piston

High efficiency 110°C			
	Front	Bag/Rear	Tip
Min.	0.15	0.05	0.07
Max	0.21	0.11	0.15

Multi-Duty 110°C			
	Front	Bag/Rear	Tip
Min.	0.20	0.09	0.07
Max	0.26	0.15	0.15

Supertight			
	Front	Bag/Rear	Tip
Min.	0.07	0.04	0.05
Max	0.13	0.10	0.11

#### DW1/004/15 - Lobe

#### DW1/007/7 - Lobe

#### DW1/007/15\_600 - Lobe

High efficiency 110°C				
	Front	Bag/Rear	Tip	Interlobe
Min.	0.10	0.05	0.08	0.12
Max	0.16	0.11	0.16	0.24

Multi-Duty 110°C				
	Front	Bag/Rear	Tip	Interlobe
Min.	0.14	0.09	0.08	0.12
Max	0.20	0.15	0.16	0.24

High temperature 180°C				
	Front	Bag/Rear	Tip	Interlobe
Min.	0.16	0.10	0.11	0.18
Max	0.22	0.16	0.19	0.30

Supertight				
	Front	Bag/Rear	Tip	Interlobe
Min.	0.07	0.05	0.06	0.06
Max	0.13	0.11	0.12	0.18

## 6. Technical data

## DW2

### DW2/006/10 - Piston

High efficiency 110°C		
Front	Bag/Rear	Tip
0.16	0.05	0.07
0.22	0.11	0.15

	Multi-Duty 110°C		
	Front	Bag/Rear	Tip
Min.	0.23	0.08	0.07
Max	0.29	0.14	0.15

	Supertight		
	Front	Bag/Rear	Tip
Min.	0.12	0.04	0.05
Max	0.18	0.10	0.11

### DW2/007/20 - Lobe

	High efficiency 110°C			
	Front	Bag/Rear	Tip	Interlobe
Min.	0.12	0.05	0.10	0.14
Max	0.18	0.11	0.18	0.28

	Multi-Duty 110°C			
	Front	Bag/Rear	Tip	Interlobe
Min.	0.16	0.08	0.10	0.14
Max	0.22	0.14	0.18	0.28

	High temperature 180°C			
	Front	Bag/Rear	Tip	Interlobe
Min.	0.17	0.10	0.14	0.22
Max	0.23	0.16	0.22	0.36

	Supertight			
	Front	Bag/Rear	Tip	Interlobe
Min.	0.12	0.06	0.08	0.03
Max	0.18	0.12	0.14	0.17

### DW2/013/10 - Lobe

### DW2/013/15\_600 - Lobe

	High efficiency 110°C			
	Front	Bag/Rear	Tip	Interlobe
Min.	0.12	0.05	0.10	0.14
Max	0.18	0.11	0.18	0.28

	Multi-Duty 110°C			
	Front	Bag/Rear	Tip	Interlobe
Min.	0.17	0.08	0.10	0.14
Max	0.23	0.14	0.18	0.28

	High temperature 180°C			
	Front	Bag/Rear	Tip	Interlobe
Min.	0.18	0.10	0.14	0.22
Max	0.24	0.16	0.22	0.36

	Supertight			
	Front	Bag/Rear	Tip	Interlobe
Min.	0.12	0.06	0.08	0.08
Max	0.18	0.12	0.14	0.22

## 6. Technical data

DW3

### DW3/014/10 - Piston

High efficiency 110°C			
	Front	Bag/Rear	Tip
Min.	0.17	0.06	0.09
Max	0.23	0.12	0.17

Multi-Duty 110°C			
	Front	Bag/Rear	Tip
Min.	0.23	0.11	0.09
Max	0.29	0.17	0.17

High temperature 180°C			
	Front	Bag/Rear	Tip
Min.	0.26	0.14	0.14
Max	0.32	0.20	0.22

Supertight			
	Front	Bag/Rear	Tip
Min.	0.07	0.06	0.06
Max	0.13	0.12	0.12

### DW3/017/20 - Lobe

High efficiency 110°C				
	Front	Bag/Rear	Tip	Interlobe
Min.	0.15	0.08	0.09	0.16
Max	0.21	0.14	0.17	0.30

Multi-Duty 110°C				
	Front	Bag/Rear	Tip	Interlobe
Min.	0.18	0.11	0.09	0.16
Max	0.24	0.17	0.17	0.30

High temperature 180°C				
	Front	Bag/Rear	Tip	Interlobe
Min.	0.20	0.14	0.14	0.25
Max	0.26	0.20	0.22	0.39

Supertight				
	Front	Bag/Rear	Tip	Interlobe
Min.	0.09	0.07	0.08	0.05
Max	0.15	0.13	0.16	0.19

### DW3/030/10 - Lobe

High efficiency 110°C				
	Front	Bag/Rear	Tip	Interlobe
Min.	0.15	0.09	0.11	0.16
Max	0.21	0.15	0.19	0.30

Multi-Duty 110°C				
	Front	Bag/Rear	Tip	Interlobe
Min.	0.19	0.11	0.11	0.16
Max	0.25	0.17	0.19	0.30

High temperature 180°C				
	Front	Bag/Rear	Tip	Interlobe
Min.	0.20	0.14	0.16	0.25
Max	0.26	0.20	0.24	0.39

Supertight				
	Front	Bag/Rear	Tip	Interlobe
Min.	0.09	0.07	0.08	0.05
Max	0.15	0.13	0.16	0.19

### DW3/030/15\_600 - Lobe

High efficiency 110°C				
	Front	Bag/Rear	Tip	Interlobe
Min.	0.15	0.09	0.11	0.16
Max	0.21	0.15	0.19	0.30

Multi-Duty 110°C				
	Front	Bag/Rear	Tip	Interlobe
Min.	0.19	0.11	0.16	0.16
Max	0.25	0.17	0.24	0.30

High temperature 180°C				
	Front	Bag/Rear	Tip	Interlobe
Min.	0.20	0.14	0.16	0.25
Max	0.26	0.20	0.24	0.39

Supertight				
	Front	Bag/Rear	Tip	Interlobe
Min.	0.09	0.07	0.08	0.05
Max	0.15	0.13	0.16	0.19

### DW3/050/5 - Lobe

High efficiency 110°C				
	Front	Bag/Rear	Tip	Interlobe
Min.	0.09	0.11	0.11	0.16
Max	0.15	0.17	0.19	0.30

Multi-Duty 110°C				
	Front	Bag/Rear	Tip	Interlobe
Min.	0.19	0.11	0.11	0.16
Max	0.25	0.17	0.19	0.30

Supertight				
	Front	Bag/Rear	Tip	Interlobe
Min.	0.09	0.07	0.08	0.05
Max	0.15	0.13	0.16	0.19

## 6. Technical data

## DW4

### DW4/033/10 - Piston

High efficiency 110°C			
	Front	Bag/Rear	Tip
Min.	0.20	0.07	0.09
Max	0.26	0.15	0.25

Multi-Duty 110°C			
	Front	Bag/Rear	Tip
Min.	0.25	0.10	0.09
Max	0.31	0.18	0.25

High temperature 180°C			
	Front	Bag/Rear	Tip
Min.	0.29	0.14	0.17
Max	0.35	0.22	0.33

Supertight			
	Front	Bag/Rear	Tip
Min.	0.10	0.06	0.07
Max	0.16	0.12	0.15

### DW4/039/20 - Lobe

High efficiency 110°C				
	Front	Bag/Rear	Tip	Interlobe
Min.	0.15	0.07	0.11	0.19
Max	0.21	0.15	0.27	0.39

Multi-Duty 110°C				
	Front	Bag/Rear	Tip	Interlobe
Min.	0.20	0.10	0.11	0.19
Max	0.26	0.18	0.27	0.39

High temperature 180°C				
	Front	Bag/Rear	Tip	Interlobe
Min.	0.22	0.14	0.17	0.30
Max	0.28	0.22	0.33	0.50

Supertight				
	Front	Bag/Rear	Tip	Interlobe
Min.	0.12	0.08	0.08	0.10
Max	0.18	0.14	0.16	0.20

### DW4/073/10 - Lobe

### DW4/073/15\_600 - Lobe

High efficiency 110°C				
	Front	Bag/Rear	Tip	Interlobe
Min.	0.15	0.07	0.12	0.19
Max	0.21	0.15	0.28	0.39

Multi-Duty 110°C				
	Front	Bag/Rear	Tip	Interlobe
Min.	0.19	0.11	0.12	0.19
Max	0.25	0.19	0.28	0.39

High temperature 180°C				
	Front	Bag/Rear	Tip	Interlobe
Min.	0.22	0.14	0.17	0.30
Max	0.28	0.22	0.33	0.50

Supertight				
	Front	Bag/Rear	Tip	Interlobe
Min.	0.12	0.08	0.08	0.10
Max	0.18	0.14	0.16	0.20

### DW4/125/5 - Lobe

Multi-Duty 110°C				
	Front	Bag/Rear	Tip	Interlobe
Min.	0.19	0.11	0.20	0.19
Max	0.25	0.19	0.36	0.39

Supertight				
	Front	Bag/Rear	Tip	Interlobe
Min.	0.14	0.08	0.08	0.10
Max	0.20	0.14	0.16	0.20

### DW4/125/7\_600 - Lobe

Multi-Duty 110°C				
	Front	Bag/Rear	Tip	Interlobe
Min.	0.19	0.11	0.22	0.19
Max	0.25	0.19	0.38	0.49

## 6. Technical data

DW5

### DW5/080/12.5 - Piston

High efficiency 110°C		
Front	Bag/Rear	Tip
0.31	0.12	0.14
0.37	0.20	0.30

	Multi-Duty 110°C		
	Front	Bag/Rear	Tip
Min.	0.36	0.14	0.14
Max	0.42	0.22	0.30

	Supertight		
	Front	Bag/Rear	Tip
Min.	0.23	0.07	0.10
Max	0.29	0.13	0.16

### DW5/093/25 - Lobe

	High efficiency 110°C			
	Front	Bag/Rear	Tip	Interlobe
Min.	0.23	0.12	0.23	0.30
Max	0.29	0.20	0.39	0.50

	High temperature 180°C			
	Front	Bag/Rear	Tip	Interlobe
Min.	0.32	0.23	0.30	0.45
Max	0.38	0.31	0.46	0.65

	Multi-Duty 110°C			
	Front	Bag/Rear	Tip	Interlobe
Min.	0.27	0.16	0.23	0.30
Max	0.33	0.24	0.39	0.50

	Supertight			
	Front	Bag/Rear	Tip	Interlobe
Min.	0.15	0.10	0.12	0.15
Max	0.21	0.16	0.18	0.29

### DW5/142/15 - Lobe

	High efficiency 110°C			
	Front	Bag/Rear	Tip	Interlobe
Min.	0.26	0.12	0.25	0.30
Max	0.32	0.20	0.41	0.50

	High temperature 180°C			
	Front	Bag/Rear	Tip	Interlobe
Min.	0.35	0.23	0.32	0.45
Max	0.41	0.31	0.48	0.65

	Multi-Duty 110°C			
	Front	Bag/Rear	Tip	Interlobe
Min.	0.31	0.16	0.25	0.30
Max	0.37	0.24	0.41	0.50

	Supertight			
	Front	Bag/Rear	Tip	Interlobe
Min.	0.15	0.10	0.12	0.15
Max	0.21	0.16	0.18	0.29

### DW5/256/7 - Lobe

	High efficiency 110°C			
	Front	Bag/Rear	Tip	Interlobe
Min.	0.29	0.12	0.32	0.30
Max	0.35	0.20	0.48	0.50

	High temperature 180°C			
	Front	Bag/Rear	Tip	Interlobe
Min.	0.38	0.22	0.39	0.45
Max	0.44	0.30	0.55	0.65

	Multi-Duty 110°C			
	Front	Bag/Rear	Tip	Interlobe
Min.	0.34	0.18	0.32	0.30
Max	0.40	0.26	0.48	0.50

	Supertight			
	Front	Bag/Rear	Tip	Interlobe
Min.	0.20	0.10	0.14	0.15
Max	0.26	0.16	0.20	0.29

## 6. Technical data

## DW6

### DW6/172/12.5 - Piston

High temperature 180°C*			
	Front	Bag/Rear	Tip
Min.			
Max			
Multi-Duty 110°C			
	Front	Bag/Rear	Tip
Min.	0.38	0.23	0.25
Max	0.44	0.29	0.41
Supertight*			
	Front	Bag/Rear	Tip
Min.			
Max			

### DW6/198/30 - Lobe

High temperature 180°C*				
	Front	Bag/Rear	Tip	Interlobe
Min.				
Max				
Multi-Duty 110°C				
	Front	Bag/Rear	Tip	Interlobe
Min.	0.28	0.23	0.30	0.41
Max	0.34	0.29	0.46	0.61

Supertight*			
Front	Bag/Rear	Tip	Interlobe

### DW6/308/15 - Lobe

High temperature 180°C*				
	Front	Bag/Rear	Tip	Interlobe
Min.				
Max				
Multi-Duty 110°C				
	Front	Bag/Rear	Tip	Interlobe
Min.	0.32	0.23	0.30	0.41
Max	0.38	0.29	0.46	0.61

Supertight			
Front	Bag/Rear	Tip	Interlobe
0.22	0.15	0.30	0.41
0.28	0.21	0.46	0.61

### DW6/519/7 - Lobe

High temperature 180°C*				
	Front	Bag/Rear	Tip	Interlobe
Min.				
Max				
Multi-Duty 110°C				
	Front	Bag/Rear	Tip	Interlobe
Min.	0.40	0.23	0.30	0.41
Max	0.46	0.29	0.46	0.61

Supertight*			
Front	Bag/Rear	Tip	Interlobe

\* Contact APV for clearances not specified



## 6. Technical data

DW7

### DW7/370/10 - Piston

High temperature 180°C*			
	Front	Bag/Rear	Tip
Min.			
Max			
Multi-Duty 110°C			
	Front	Bag/Rear	Tip
Min.	0.38	0.23	0.25
Max	0.44	0.29	0.41
Supertight*			
	Front	Bag/Rear	Tip
Min.			
Max			

### DW7/420/30 - Lobe

High temperature 180°C*				
	Front	Bag/Rear	Tip	Interlobe
Min.				
Max				
Multi-Duty 110°C				
	Front	Bag/Rear	Tip	Interlobe
Min.	0.33	0.23	0.30	0.46
Max	0.39	0.29	0.46	0.66
Supertight*				
	Front	Bag/Rear	Tip	Interlobe
Min.				
Max				

### DW7/725/15 - Lobe

High temperature 180°C*				
	Front	Bag/Rear	Tip	Interlobe
Min.				
Max				
Multi-Duty 110°C				
	Front	Bag/Rear	Tip	Interlobe
Min.	0.41	0.23	0.30	0.46
Max	0.47	0.29	0.46	0.66
Supertight*				
	Front	Bag/Rear	Tip	Interlobe
Min.				
Max				

### DW7/1016/7 - Lobe

High temperature 180°C*				
	Front	Bag/Rear	Tip	Interlobe
Min.				
Max				
Multi-Duty 110°C				
	Front	Bag/Rear	Tip	Interlobe
Min.	0.48	0.23	0.30	0.46
Max	0.54	0.29	0.46	0.66
Supertight*				
	Front	Bag/Rear	Tip	Interlobe
Min.				
Max				

\* Contact APV for clearances not specified

# DW Pump

ROTARY LOBE PUMPS



## **SPX FLOW TECHNOLOGY POLAND sp. z o.o.**

Hermana Frankego 9  
85-862 Bydgoszcz, Poland  
Phone: +48 52 525 9900  
Fax: +48 52 525 9909

SPX reserves the right to incorporate our latest design and material changes without notice or obligation.

Design features, materials of construction and dimensional data, as described in this bulletin, are provided for your information only and should not be relied upon unless confirmed in writing. Please contact your local sales representative for product availability in your region. For more information visit [www.spx.com](http://www.spx.com)

ISSUED 12/2012 - Original Manual  
Copyright © 2012 SPX Corporation