

Flowline products and services



Worldwide distribution

TechnipFMC is the world's leading supplier of flowline products and services to the oilfield industry and is the standard against which all others are measured. From the original Chiksan® and Weco® products to the revolutionary equipment designs and integrated services of today, TechnipFMC's flowline family of products and services enables customers to achieve maximum life and value from their flowline systems through a range of applications.



The success of TechnipFMC's flowline technology stems from a strong tradition of anticipating and responding to customer needs in every way possible.

By focusing on the delivery of top products and services, TechnipFMC is helping its customers face tomorrow's technical and economic challenges today.

Chiksan and Weco products are distributed from more than 60 locations worldwide. Our facilities stock flowline products in the specific sizes, pressures, and materials common to each region. From a replacement seal for a Chiksan swivel joint to a platform full of well servicing equipment, TechnipFMC delivers.

Experienced, knowledgeable, productive people

TechnipFMC's global flowline team is structured around top flowline professionals who understand your business and are dedicated to meeting your needs. The management, engineering, and sales support staff are among the most experienced in the oil and gas industry. Their knowledge and industry expertise show up in the quality of products and services delivered to you.

Health, safety and environment

As a leading oilfield equipment and services provider, TechnipFMC stresses overall health, safety, and environment (HSE) in all of its operations and processes. With a proven record of outstanding HSE performance, TechnipFMC is a strong advocate of HSE training that goes beyond the basic legal requirements. The goal is to ensure that all field and office personnel are competent to carry out HSE critical duties, having received the appropriate training required by law, company policy, and clients. HSE policy covers all key elements of the business, including company safety policy statements, product safety, risk assessment, monitoring, auditing, and review.

Research and development

To meet the evolving needs of its customers, TechnipFMC continually invests in flowline research and development. This industry-leading effort has resulted in a host of new products and refinements to existing products. All new products are subjected to exhaustive laboratory and field tests to ensure their reliability and integrity before they are released to the market-place. Research and development capabilities include exhaustive laboratory and field testing, destructive and nondestructive testing, three-dimensional finite element analysis, computational fluid dynamics, and the flowline industry's only high-velocity flow loop.

Manufacturing leader

TechnipFMC's flowline manufacturing facility is located in Stephenville, Texas. The plant was constructed in 1980 and expanded in 1984, 1987, 1996 and 2012. The facility occupies a 39-acre site and comprises 350,000 square feet of manufacturing and office space for customer service, production support, and engineering offices. It utilizes the latest in computer numerical controlled (CNC) machining centers, production planning systems, computer aided design/computer aided manufacturing (CAD/CAM) systems, and the latest technology in order and distribution operating systems. The Stephenville facility produces a wide range of surface equipment for distribution worldwide.



Flowline manufacturing facility, Stephenville, Texas

Unsurpassed quality

TechnipFMC's flowline quality system has been surveyed and approved by the American Petroleum Institute (API) for Q1 and ISE 9001:2015. The facility has also been surveyed and approved by DNVGL to meet Annex III Module H of Directive 2014/68/EU on all pressure equipment. Most products are supplied with the CE marking. Chiksan and Weco products also can be supplied with both type and case approval from DNVG, Lloyds, ABS, GGTN, and others. Products for sour gas service meet NACE MR-01-75 and API RP-14-E. Material certification and traceability are also available.



World class manufacturing and quality.

Integrated services

To satisfy the total requirements of its clients, TechnipFMC has consolidated its industry-leading after-sales capabilities into a comprehensive services program. Our commitment is helping clients worldwide realize the maximum value from their pressure pumping assets to guarantee that the right products are shipped to the job site in top working condition. This total solutions approach includes the InteServ tracking and management system, mobile inspection and repair, strategically located service centers, and genuine Chiksan and Weco spare parts.

Contents

Flowline products

Plug valves	4
Check valves	10
Pressure relief valves	13
Butterfly valves	14
Swivel joints	30
Sour gas swivel joints	34
Cementing and circulating hoses	36
Wing unions	46
Fittings and pup joints	58
Temporary Pipe Restraint (TPR)	70
Flexible pipe	82
Manifold trailers and skids	84

Inspection services and InteServ	86
----------------------------------	----

Warnings and cautions	88
-----------------------	----

Contact Us	89
------------	----



Weco® plug valves

Weco® ULT and DR plug valves are premium, quarter-turn valves designed for a wide range of standard and sour gas drilling, production, and well-servicing applications. These rugged valves are offered in single and dual-body designs in pressures up to 20,000 psi. They range in size from 1 to 4-inches and come with threaded, Weco® wing union, flanged, and clamp hub ends. Consult factory for configurations. Like all pressure containing products, Weco® plug valves require special handling. **(See warnings and cautions, pg. 88).**

Benefits

The benefits of TechnipFMC's ULT plug valves are a direct result of its unique design features. Combined, these features have redefined the standards for plug valve operating principles and performance.

- 1. Choice of operators, actuators**
Gear operators, pneumatic actuators and hydraulic actuators are available.
- 2. Ultimate sealability, no adjustments required**
Floating plug improves sealability and reduces plug wear.
- 3. Low torque operation at all pressures**
Cylindrical plug fits between seal and side segments, reducing plug drag on the valve body.
- 4. Body erosion virtually eliminated**
Fluid is forced between the plug/seal interface, limiting wear to replaceable parts.



Ultimate sealability

The key to the ULT plug valve's unprecedented seal integrity is its proprietary floating plug and dual-seal design. When the valve is closed, the dual segment seal provides a redundant seal on the downstream side of the valve. In 3-inch and larger sizes, the ULT plug valve also employs a two-piece plug and stem design. When these valves are closed, line fluid pressure in the body is equalized around the plug resulting in ultimate sealing and low operating torque.

Ultimate valve body life

In addition to improved bidirectional seal performance, the ULT plug valve dramatically extends service life. When a traditional plug valve is closed, high-pressure fluids are forced between the upstream body and seal segment interface. This flow path can erode the valve body, potentially ruining the valve. When a ULT plug valve is closed, the only available flow path is between the seal segment and plug interface. This flow path eliminates body erosion and limits any potential wear to replaceable components.

Ultimate seal life

In addition to improved valve body life, two other frequent operating problems associated with high-pressure plug valves – both of which cause premature damage to seals and increased valve operating torque – are solved by the ULT plug valve. Traditional plug valve designs can sometimes seal on the upstream side of the valve, resulting in extrusion damage to the upstream segment seal. Traditional plug valves can also trap body pressure after line pressure is removed from the valve, resulting in extrusion damage to both upstream and downstream segment seals. The dual-seal design of the ULT plug valve, by forcing flow between the plug and segment interface, eliminates both of these problems.

Ultimate life cycle cost savings

Superior sealability, increased life of valve body and elimination of premature seal damage result in significant savings in life cycle costs of the ULT plug valve over traditional plug valves. Qualification tests have proven that the ULT plug valve extends service life 3 to 5 times over other plug valves while reducing maintenance costs. On 1 inch size, ULT parts kits may be used in existing DR plug valve bodies to extend the life of these valves.

➤ See specifications tables (pgs. 10-11) for sizes, dimensions, weights, materials, and part numbers.

Operating principal:

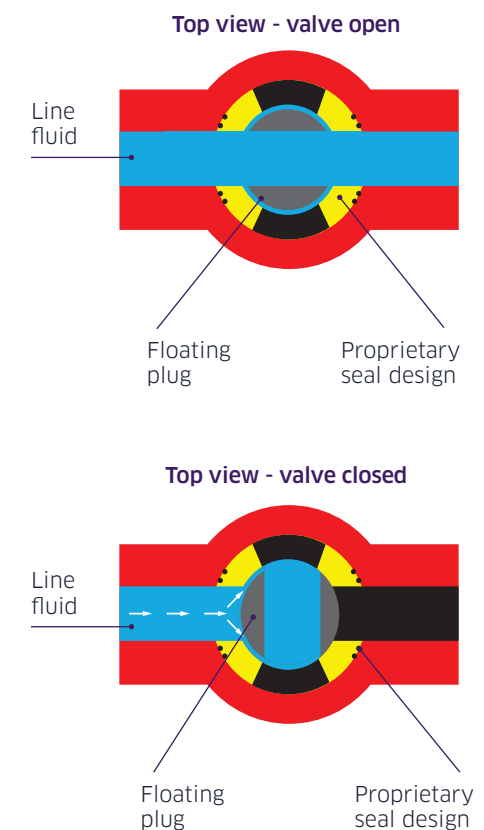

Weco® plug valves

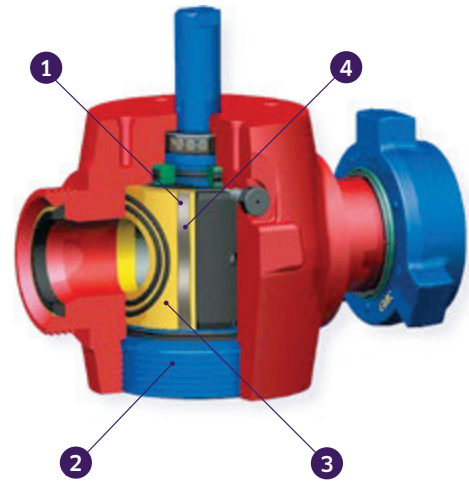

ULT plug valves (3-inch and larger)

Up to 20,000 psi cold working pressure

Recommended service

Slick water, sand, proppant/gel, energized fluids, inhibited acids and cement

- 1. Two-piece floating plug/stem**
Proprietary floating plug and stem uniformly distribute load against the downstream seat to improve sealability and reduce plug wear..
- 2. Fast, simple field repair**
Bottom entry design provides access to all valve internals without having to remove the operator or actuator.
- 3. Eliminates body washout, extends body life**
Dual seals direct flow between the seal segment and plug to provide long, trouble-free service life.
- 4. Handles sand, proppant, and cement**
Linear wave springs prevent small particles from entering metal-to-metal seal area, enabling use in a broad range of applications.

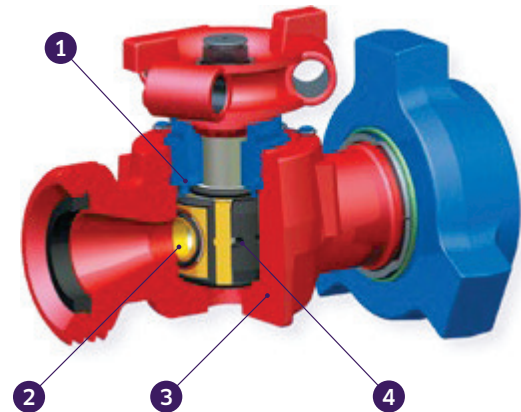

ULT plug valves (below 3-inch)

Up to 20,000 psi cold working pressure

Recommended service

Slick water, sand, proppant/gel, energized fluids, inhibited acids and cement

- 1. Eliminates body washout, extends body life**
Dual seals direct flow between the seal segment and plug to provide long, trouble-free service life.
- 2. Fast assembly**
Integral stem and plug provide fast, sure assembly without adjustments.
- 3. Interchangeable design**
Internal components of 1" size interchange with Weco® DR valve components, potentially extending the life of those valve bodies.
- 4. Eliminates corrosion in segment sealing area**
Dual segment seals greatly reduce erosive fluid flow between the seal segments and the plug valve body to improve sealing capabilities and extend service life.

Specialty ULT Plug Valves

The ULT plug valve's proven, proprietary design technology enables customers to take advantage of a wide range of configurations for a host of specialty applications. Options include single and dual body designs; drill pipe, Weco® union, or flanged end connections; and side outlets. **(Consult factory for specific applications).**

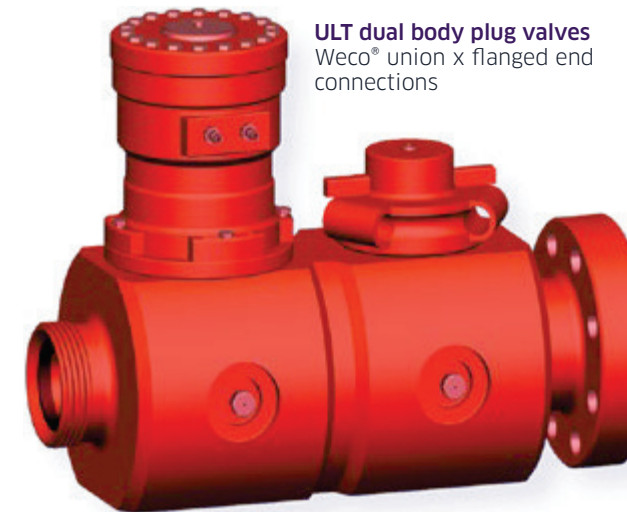

ULT dual body plug valves
Weco® union x flanged end connections

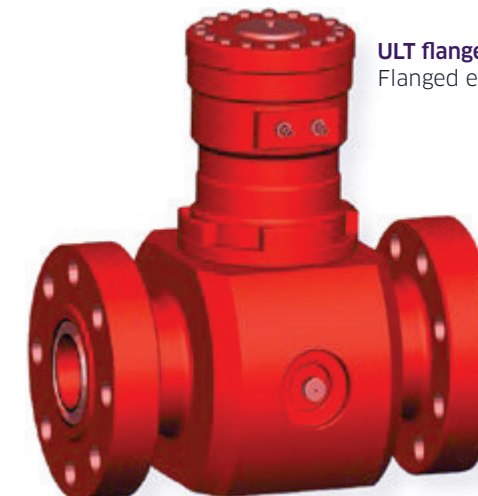

ULT flanged plug valves
Flanged end connections

See specifications tables (pgs. 8-9) for sizes, dimensions, weights, materials, and part numbers.

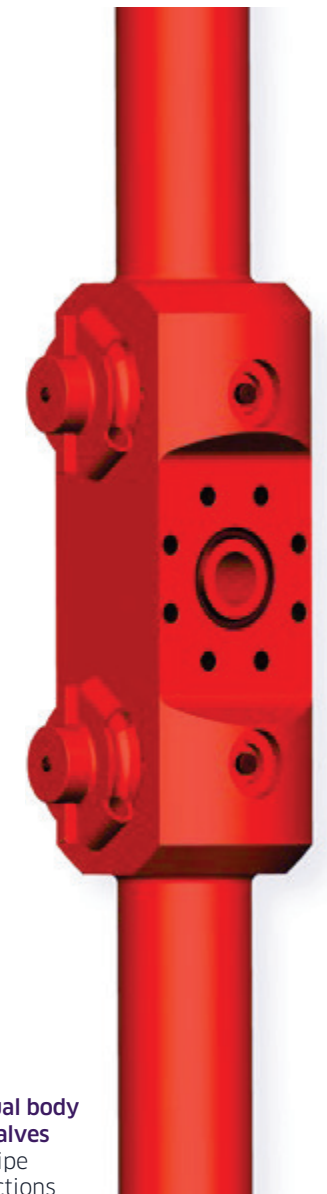

ULT dual body plug valves
Drill pipe connections

Weco® plug valve specifications

Weco® and Chiksan® low temperature ranges (LT)

TechnipFMC leads the way with our new line of low temperature (-40°C) equipment. Please consult a TechnipFMC representative for more information on our standard service flowline low temperature products.

Plug valve model	Nominal size, in.	P/N	P/N-LT	Weco end connection *	Service	CWP psi bar	lb kg
ULT 150	1	P516114	-	1502	Standard	15,000 1034	33 15
ULT 100	1	P524578	-	1502	Sour	10,000 690	33 15
ULT 150	1x2	P516108	P516108-LT	1502	Standard	15,000 1034	43 (19.5)
	1x2 (.38 bore)	P516146	-	1502	Standard	15,000 1034	58 (26.3)
ULT 100	1x2	P516208	-	1502	Sour	10,000 690	43 (20)
ULT 150	2	P537789	-	1502	Standard	15,000 1034	84 (38)
DR 200	2	3234183	-	2202	Sour	15,000 1034	98 (45)
ULT 150 (Manual)	3	3265904	-	1502	Standard	15,000 1034	238 (108)
ULT 100 (Manual)	3	P501010	-	1502	Sour	10,000 690	231 (105)
ULT 150 (Manual)	3	P555686	-	1505	Standard	15,000 1034	247 (112)
ULT 100 (Handwheel)	3	P556455	-	1505	Standard	15,000 1034	314 (143)
ULT 150 (Hydraulic)	3	3265123	-	1502	Standard	15,000 1034	412 (187)
ULT 100 (Hydraulic)	3	3267427	-	1502	Sour	10,000 690	405 (184)
ULT 150 (Handwheel)	3	3265122	-	1502	Standard	15,000 1034	305 (139)
ULT 100 (Handwheel)	3	3265257	-	1502	Sour	10,000 690	315 (143)
ULT 200 (Hydraulic)	3	P519087	P519087-LT	2002	Standard	20,000 (1380)	845 (384)
ULT 150 (Handwheel)	3	P522233	-	2202	Sour	15,000 1034	689 (313)
ULT 100 (Hydraulic)	4	P518352	P518352-LT	1002	Standard	10,000 690	830 (377)
ULT 100 (Handwheel)	4	P518356	P518356-LT	1002	Standard	10,000 690	633 (287)
ULT 150 (Hydraulic)	4	P516015	P516015-LT	1502	Standard	15,000 1034	871 (395)
ULT 150 (Handwheel)	4	P518749	P518749-LT	1502	Standard	15,000 1034	716 (325)

Plug valve model	Nominal size, in.	A in. (mm)	B in. (mm)	C in. (mm)	D in. (mm)	E in. (mm)	F in. (mm)	G in. (mm)
ULT 150	1	4.69 (119)	5.88 (149)	6.59 (167)	1.75 (45)	2.88 (73)	-	-
ULT 100	1	4.69 (119)	5.88 (149)	6.59 (167)	1.75 (45)	2.88 (73)	-	-
ULT 150	1x2	4.69 (119)	5.88 (149)	6.59 (167)	1.75 (45)	3.93 (100)	-	-
	1x2 (.38 bore)	4.69 (119)	5.88 (149)	6.59 (167)	1.75 (45)	3.93 (100)	-	-
ULT 100	1x2	4.69 (119)	5.88 (149)	6.59 (167)	1.75 (45)	3.93 (100)	-	-
DR 150	2	6 (152)	7.88 (200)	8.05 (205)	2.62 (67)	3.93 (100)	-	-
	2	6 (152)	7.88 (200)	8.05 (205)	2.62 (67)	3.93 (100)	-	-
DR 200	2	6.06 (154)	9.19 (233)	8.05 (205)	2.62 (67)	3.76 (96)	-	-
	2	6.06 (154)	9.19 (233)	8.05 (205)	2.62 (67)	3.76 (96)	-	-
ULT 150 (Manual)	3	-	-	14.27 (363)	5 (127)	4.55 (116)	-	15.69 (399)
ULT 100 (Manual)	3	-	-	14.27 (363)	5 (127)	5.25 (133)	-	15.69 (399)
ULT 150 (Manual)	3	-	-	14.49 (368)	5 (127)	5.25 (133)	-	15.69 (399)
ULT 100 (Handwheel)	3	-	-	14.49 (368)	5 (127)	5.25 (133)	-	15.69 (399)
ULT 150 (Hydraulic)	3	-	-	21.81 (554)	5 (127)	4.55 (116)	-	15.69 (399)
ULT 100 (Hydraulic)	3	-	-	21.81 (554)	5 (127)	4.55 (116)	-	15.69 (399)
ULT 150 (Handwheel)	3	-	-	14.47 (368)	5 (127)	4.55 (116)	22.12 (562)	15.69 (399)
ULT 100 (Handwheel)	3	-	-	14.47 (368)	5 (127)	4.55 (116)	22.12 (562)	15.69 (399)
ULT 200 (Hydraulic)	3	-	-	29.63 (753)	6.26 (159)	6 (152)	-	22.08 (561)
ULT 200 (Handwheel)	3	-	-	17.62 (448)	6.26 (159)	6 (152)	36.88 (937)	22.08 (561)
ULT 150 (Handwheel)	3	-	-	17.62 (448)	6.26 (159)	6 (152)	36.88 (937)	22.08 (561)
ULT 100 (Hydraulic)	4	-	-	28.49 (724)	7.00 (118)	4.94 (126)	-	22.85 (580)
ULT 100 (Handwheel)	4	-	-	19.1 (485)	7.00 (118)	4.94 (126)	38.36 (974)	22.85 (580)
ULT 150 (Hydraulic)	4	-	-	28.49 (724)	7.00 (118)	4.94 (126)	-	22.85 (580)
ULT 150 (Handwheel)	4	-	-	19.1 (485)	7.00 (118)	4.94 (126)	38.29 (973)	22.85 (580)

Note: * Other end connections are available. Consult factory.

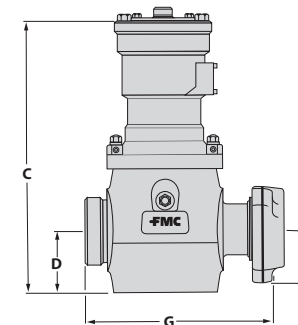
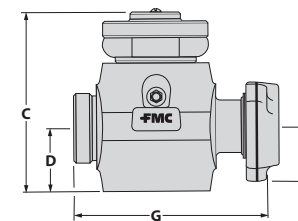
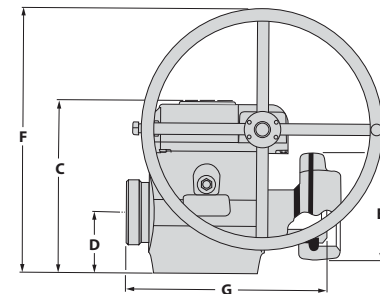
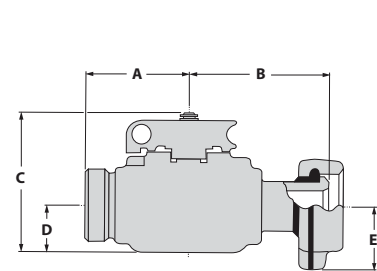

- 1", 1x2" ULT 150, DR150 and DR200 plug valves can be furnished with hydraulic actuators.

Weco® check valves

TechnipFMC has redesigned the top entry check valve and added new, proprietary materials. These changes provide improved structural support and erosion tolerance, including added resistance to corrosive chemicals. The result is extended valve life – 2-3X life in acid service or 4-5X life in standard service.

Extended life 3” 15k top entry check valve

The WECO® Extended life 3”15k top entry check Valve eliminates the need for special tools and reduces non-productive time which saves you time and money. The hammer union style body cap is easily detached, allowing access to hand removable internals for field servicing.

Like all pressure containing products, Weco check valves require special handling. (See See warnings and cautions, pg. 88)

Recommended service:

high-pressure well-servicing lines, fracturing lines, testing lines, cementing and circulating lines, and other well service and stimulation applications.

Top entry check valve parts

Part No. P558733

Standard Flow Check Valve Assembly

Part No. P561165

Reverse Flow Check Valve Assembly

Replacement kits

Kit 1 – Part No. P561370

(Flapper and pin)

Kit 2 – Part No. P561369

(Flapper, pin, o-rings and body plug)

Kit 3 – Part No. P561861

(Cartridge insert, pin, body plug, o-rings)

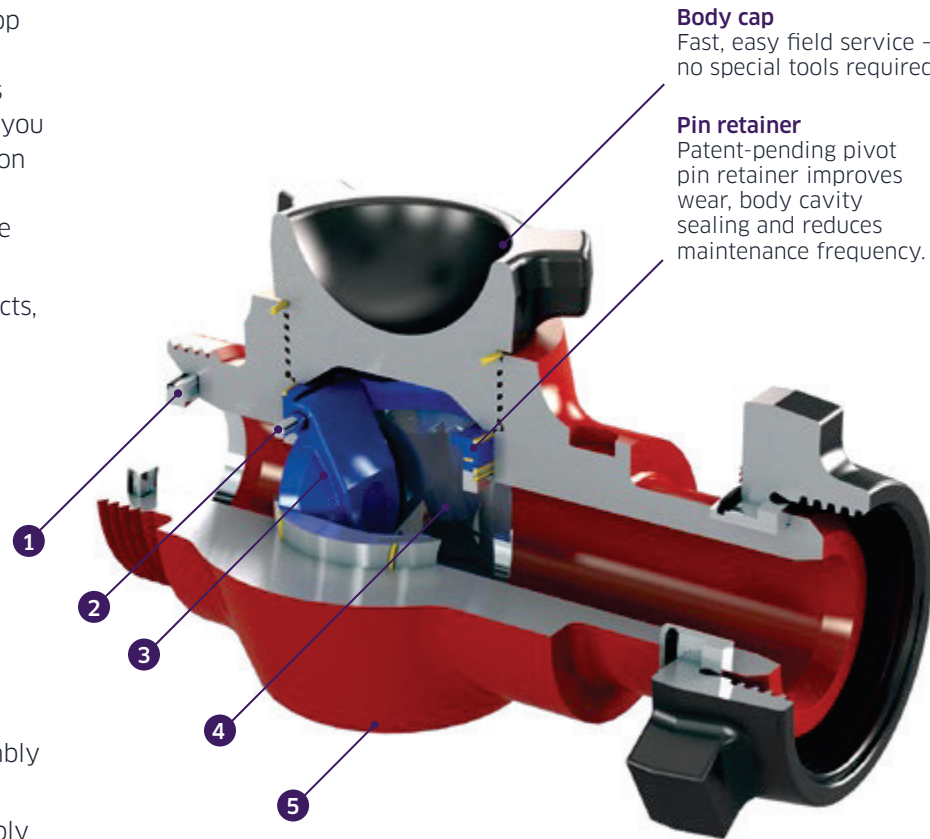

Body cap
Fast, easy field service – no special tools required.

Pin retainer
Patent-pending pivot pin retainer improves wear, body cavity sealing and reduces maintenance frequency.

1. Seal ring
2. Pivot pin
3. Flapper
4. Seat cartridges
5. Body plug

Dart check valves

Recommended service

Extreme nitrogen and carbon dioxide services; wet or dry non-erosive flow.

1. **Minimizes explosive decompression**
Explosive decompression resistant materials and design for long service life.
2. **N2 and CO2 capability**
Stainless steel internal components and special elastomer seal handle gas velocities in excess of 250 feet/second.
3. **Low-inertia dart design**
Hollow dart and fixed stem minimize pressure required to start flow. Non-metallic bushing reduces friction, increasing dart and stem life.
4. **Easy, low-cost service**
Main seal is located on seat, reducing exposure to flow. Enables seal to be replaced without replacing seat or dart.

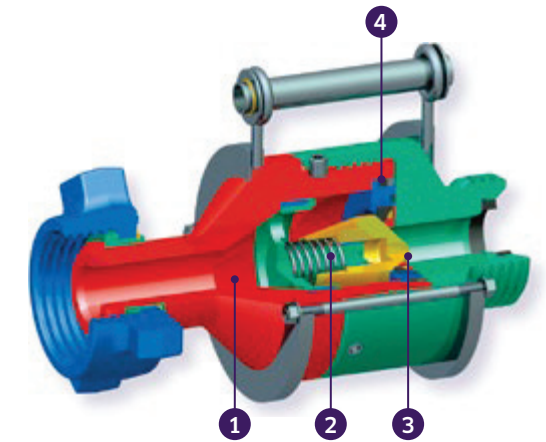

➤ See specifications tables (pg. 12) for sizes, dimensions, weights, materials, and part numbers.

Inline flapper check valves

Recommended service

Slick water, sand, proppant/gel, and cement services

1. **Open flow path**
Flapper dynamics provide optimum flow through the valve and low flow differential.
2. **Abrasion resistant flapper**
Carboxylated nitrile flapper face is abrasion resistant against a complete range of well fluids.
3. **Replaceable seat**
Separate seat/body design ensures the seat can be replaced as needed.

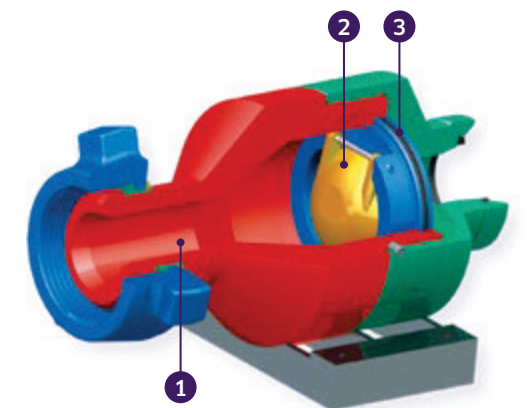

Weco® check valves

Top entry check valves

Nominal size	CWP	Service	End connections	Flow	Part number	P/N - LT	in. (mm)	in. (mm)	lb kg	Repair kit	Elastomer set
2"	15,000	Standard	1502 MxF	Standard	P530589	P530589-LT	13.12 333	8.27 211	70 31.75	P528681	P528686
	15,000	Standard	1502 FxM	Reverse		P537198-LT	13.12 333	8.27 211	70 31.75	P528681	P528686
	15,000	Standard	1502 MxF	Standard		P537131-LT*	13.12 333	8.27 211	69 31.3	P528681	P528686
	10,000	Sour Gas	1502 FxM	Standard		P537196-LT	13.12 333	8.27 211	70 31.75	P537904	P537905
3"	15,000	Standard	1502 MxF	Standard	P558733	-	15.67 398	9.52 242	130 59	P561370 P561369 P561861	-
	15,000	Standard	1505 MxF	Standard	P562345	-	15.67 398	9.52 242	141 64	P561370 P561369 P561861	-
	15,000	Standard	1502 MxF	Reverse	P561165	-	15.67 398	9.52 242	130 59	P561370 P561369 P561861	-
	10,000	Sour Gas	1502 FxM	Standard	P537225	-	15.67 398	9.54 242	127 58	P508059	P508060
	6,000	Standard	602 MxF	Standard	P537202	-	15.67 398	9.54 242	124 57	P522215	P523359
	6,000	Standard	602 FxM	Reverse	P527120	-	15.67 398	9.54 242	124 57	P522215	P523359
4"	15,000	Standard	1502 MxF	Standard	P524760	-	19.75 502	11.88 302	276 126	P525441	P525505
	15,000	Standard	1502 MxF	Reverse	P527699	-	19.75 502	11.88 302	276 126	P525441	P525505
	10,000	Standard	1002 MxF	Standard	P525809	-	19.75 502	11.88 302	240 109	P525441	P525505
	10,000	Standard	1002 MxF	Reverse	P527018	-	19.75 502	11.88 302	240 109	P525441	P525505
	6,000	Standard	602 MxF	Standard	P527592	-	19.75 502	11.88 302	239 109	P525441	P525505

Note: * Vent cap

In-Line flapper check valves

Nominal size	CWP	Service	End connections	Flow	Part number	P/N - LT	in. mm	in. mm	lb kg	Repair kit	Elastomer set
2"	20,000	Standard	2002 MxF	Standard	P3269158	-	16.91	8.00	123 56	P519720	P535387
	20,000	Standard	2002 MxF	Reverse	P558714	-	16.91	8.00	123 56	P519720	P535387
1"	20,000	Standard	2002 MxF	Standard	P524738	-	16.91	8.00	123 56	P519720	P535387
1½"	20,000	Standard	2002 MxF	Standard	P543340	-	16.91	8.00	123 56	P519720	P535387
	20,000	Standard	2002 MxF	Reverse	P519734	-	16.91	8.00	123 56	P519720	P519720
3"	20,000	Standard	2002 MxF	Standard	P520099	-	16.91	8.00	123 56	P519720	P535387

Dart check valves

Nominal size	CWP	Service	End connections	Flow	Part number	P/N - LT	in. mm	in. mm	lb kg	Repair kit	Elastomer set
1"	15,000	Standard	1502 MxF	Standard	P536118	-	14.04	10.31	76 35	P518835	P518834
1½"	15,000	Standard	1502 MxF	Reverse	P523811	-	14.04	10.31	86 39	P518835	P518834
	15,000	Standard	1502 MxF	Standard	P525269	-	14.04	10.31	84 39	P518835	P518834
2"	15,000	Standard	1502 MxF	Standard	P510771	-	14.04	10.31	87 40	P518835	P518834
3"	15,000	Standard	1502 MxF	Standard	P510773	-	15.67	11.43	130 59	P519874	P519873

Pressure relief valves

The TechnipFMC electronically controlled pressure relief valve (ePRV) automatically reseats after an over pressure event and improves reliability and accuracy while reducing personnel exposure at the wellsite. Unlike other full opening pressure relief valves, the ePRV is electrically powered and requires no gas bottles or hoses, reducing the exposure of your people and protecting your equipment.

Solution engineered

Currently the markets' primary option for a full-opening pressure relief valve is complex, requiring nitrogen storage cylinders, control panels and additional plumbing. Their ability to maintain accurate set points is compromised by changes in ambient conditions. The TechnipFMC Electronically Controlled Pressure Relief Valve (ePRV) is solution engineered with simplicity, reduced exposure and reliability in mind.

With the ability to re-seat itself without manual intervention, your employees stay out of the red zone, resulting in less personnel exposure, less downtime and improved production. Unlike other full-opening pressure relief valves, the ePRV is electrically powered and requires no gas bottles or hoses, improving the protection of your people and equipment. The ePRV provides means for a more accurate trip pressure due to fact that is controlled by customer pressure transducers.

The cost of an over-pressure event is difficult to quantify. These costs could include scrapped equipment, downtime, equipment recertification, and pollution or litigation liability, which can all potentially have long standing negative effects on the success of your company. The ePRV will accurately and rapidly relieve the full line pressure allowing you to trouble shoot the root cause of the incident. It also comes standard with Weco® end connections, which are known for their proven reliability.

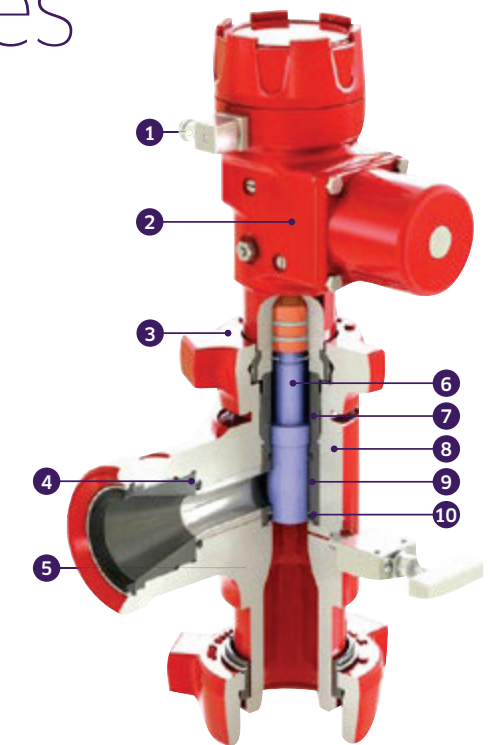

ePRV

1. Electrical inlet
2. Pilot valve body
3. Pilot valve mounting nut
4. ePRV exit bore insert
5. ePRV main valve body
6. ePRV poppet
7. ePRV cage
8. Cage to main valve body seal
9. Cage to poppet seal
10. ePRV port seal ePRV cage face seal

Nominal size	CWP	Service	End connections	Product	Part number	in. mm	in. mm	lb kg	Repair kit
2"	1000	Standard	1502 MxF	Spring Stack	P526296	7.50 191	7.50 191	62 29	P540417
2"	15,000	Standard	1502 MxF	-	3266005	7.50 191	7.50 191	62 29	3267382
2"	20,000	Standard	2002 MxF	-	P556564	6.06 154	6.87 175	64 29	P504268
3"	15,000	Standard	1502 MxF	-	3267874	8.00 203	8.00 203	182 83	P507520
2"	10,000	Sour	1502 MxF	Sour Gas	P500374	7.50 191	7.50 191	62 29	P504649
3"	15,000	Standard	1502 MxF	Electronic	P557316	8.38 213	8.38 213	159 73	P557277

Weco® butterfly valves

Weco® butterfly valves offers dependable, economical flow control. These field-proven valves are available from stock in 2 through 24-inch sizes and can handle working pressures up to 175 psi. For pressure ratings from 176 psi up to 285 psi, consult factory. Wafer, notched, and lug-type body styles meet requirements for new or existing flowline systems. Using a variety of materials, valve bodies, discs, stems, and seats can be individually matched to specific operating conditions, including temperature range, type and concentration of fluid, and various flow conditions

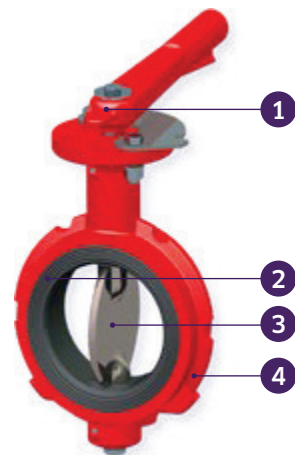

1. Choice of operators, actuators

All Weco® butterfly valve models can be equipped with a wide range of operators and actuators.

2. Leak-proof installation

Ribbed seat face eliminates the need for flange gaskets and ensures leak-proof installation.

3. Outstanding flow efficiency

Streamlined disc design minimizes turbulence and pressure drop for greater flow efficiency.

4. Fast, simple field repair

If a valve should need repair, it can be completely reconditioned in the field using interchangeable stock parts.

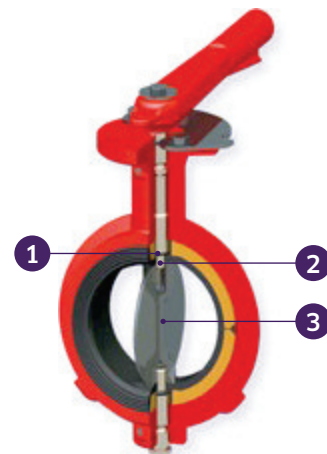

1. Triple seal design

An O-ring, undersized stem holes in the seat, and corresponding flats on seat and disc hubs provide three completely independent seals. This unique feature isolates both the upper and lower stems from line fluid, allowing use of standard stem material..

2. No in-line pins, screws or bolts

Hex drive provides positive disc movement without in-line pins, screws, or bolts.

3. Self-centering disc

Dual stem with upper and lower tangential pins allows a self-centering disc. This design provides equal sealing pressure 360° around the disc, ensuring positive shut off and extending service life.

Body styles

Model 12

Short neck, wafer body; 175 psi cold working pressure, 2 to 12-inch sizes; 150 psi cold working pressure, 14 and 16-inch sizes



Recommended service

General on/off and throttling services from 1mm Hg absolute vacuum to full working pressure

- ▶ Valves are self-centering and mount between 125 or 150 lb ANSI flanges

Model 12N

Short neck, notched body; 175 psi cold working pressure, 2 to 6-inch sizes



Recommended service

General on/off and throttling services from 1mm Hg absolute vacuum to full working pressure

- ▶ Valves are notched to fit between lightweight flanges

Model 22

Long neck, wafer body; 175 psi cold working pressure, 2 to 12-inch sizes



Recommended service

General on/off and throttling services from 1mm Hg absolute vacuum to full working pressure

- ▶ Valves are self-centering and mount between 125 or 150 lb ANSI flanges
- ▶ Long neck allows for pipe insulation

Model 22L

Long neck, lug body, 175 psi cold working pressure, 2 to 24-inch sizes



Recommended service

General on/off and throttling services from 1mm Hg absolute vacuum to full working pressure

- ▶ Tapped lugs allow independent upstream or downstream bolting to 125 or 150 lb ANSI flanges
- ▶ Long neck allows for pipe insulation

➤ See specifications tables (pgs. 17-31) for sizes, dimensions, weights, materials, and part numbers.

Weco® butterfly valve operators and actuators

All models and sizes of Weco® butterfly valves can be equipped with Weco® operators or actuators as well as other brands of actuators. Typical options include standard and throttling handles, gear operators, chain-wheel operators, vane actuators, pneumatic actuators, special controllers, and positioners.

Standard handle

2 through 12-inch valve sizes



Recommended service

Manual on/off service

- ▶ Positive-stop gripper with integral locking lug ensures full open/full closed operation
- ▶ Model 12 and 12N valves have a detent plate which bolts on the valve body in each of four quadrants
- ▶ Model 22 and 22L valve have a pre-notched top flange with on/off detent positions

Throttling handle

2 through 12-inch valve sizes



Recommended service

Manual throttling service

- ▶ Notched detent plate and positive-stop gripper with integral locking lug ensures positive locking in any of 10 positions from full open or full closed operation
- ▶ Detent plate bolts on the valve body in each of the four quadrants

Pneumatic actuators

Quarter-turn, double acting actuator; 2 through 6-inch valve sizes



Recommended service

Compact, pneumatic actuator for on/off valve operation

- ▶ The only moving part, the vane, is cast integral to the shaft for sturdiness; does not require field lubrication
- ▶ Fully repairable in-line
- ▶ Mounts directly to valve in any quadrant

Gear operators

Weatherproof, worm gear operator; 2 through 24-inch valve sizes



Recommended service

Manual on/off or throttling services

- ▶ Operator has 90° travel arc with internal travel stop screws for a plus or minus 20° adjustment at either end of the travel
- ▶ Mounts on the valve in any quadrant
- ▶ Chain wheel attachment available
- ▶ Hand-wheel shaft extensions available

Stem extension



Weco® butterfly valve specifications

Model 12

Sizes	2"	2½"	3"	4"	6"	8"	10"	12"	14"	16"	
P/N	3227485	3227486	3227487	3245819	3227493	3232417	3227495	3227496	3255865	3255869	
P/N - LT											
Dimensions, in., mm	A	4¾ 126	5.91 150	5¾ 150	7¾ 185	7¾ 198	9¾ 239	10¾ 271	12¾ 309	14¾ 380	17⅞ 443
	B	3 76.2	3½ 84.9	3¾ 92.1	4¼ 108	5⅞ 135	7 178	8¼ 210	9¼ 248	10⅞ 264	11⅞ 303
	C	4⅞ 105	4⅞ 124	5 137	6⅞ 175	8¼ 222	11 279	13⅞ 340	16⅞ 410	17⅞ 449	20⅞ 511
	D	2⅞ 52.4	2½ 63.5	3⅞ 77.8	4⅞ 103	6⅞ 154	8⅞ 205	10 254	12 305	13¼ 337	15¼ 387
	E	¾ Sq. 15.9	¾ Sq. 15.9	¾ Sq. 15.9	¾ Sq. 15.9	¾ Sq. 15.9	¾ Sq. 22.2	¾ Sq. 22.2	1¼ Sq. 28.6	1¼ Sq. 28.6	2* 50.8
	F	4 102	4 102	4 102	4 102	4 102	6 152	6 152	6 152	6 152	8 203
	G	1½ 26.2	1½ 26.2	1½ 26.2	1½ 32.5	1½ 32.5	1½ 32.5	1½ 32.5	1½ 32.5	1½ 32.5	3⅞ 81
	H	1⅞ 41	1¼ 45	1¼ 45	2 51	2⅞ 54	2⅞ 64	2⅞ 64	3 76	3 76	4 102
	I	⅞ 11.1	⅞ 11.1	⅞ 11.1	⅞ 11.1	⅞ 11.1	⅞ 14.3	⅞ 14.3	⅞ 14.3	⅞ 14.3	⅞ 13.5
	J	3¼ 82.6	3¼ 82.6	3¼ 82.6	3¼ 82.6	3¼ 82.6	5 127	5 127	5 127	5 127	6½ 165

Note: - **Body:** Ductile iron **Disc:** Ductile iron **Stems:** Stainless steel **Seat:** Nitrile
* 2 inch diameter with ½ inch keyway

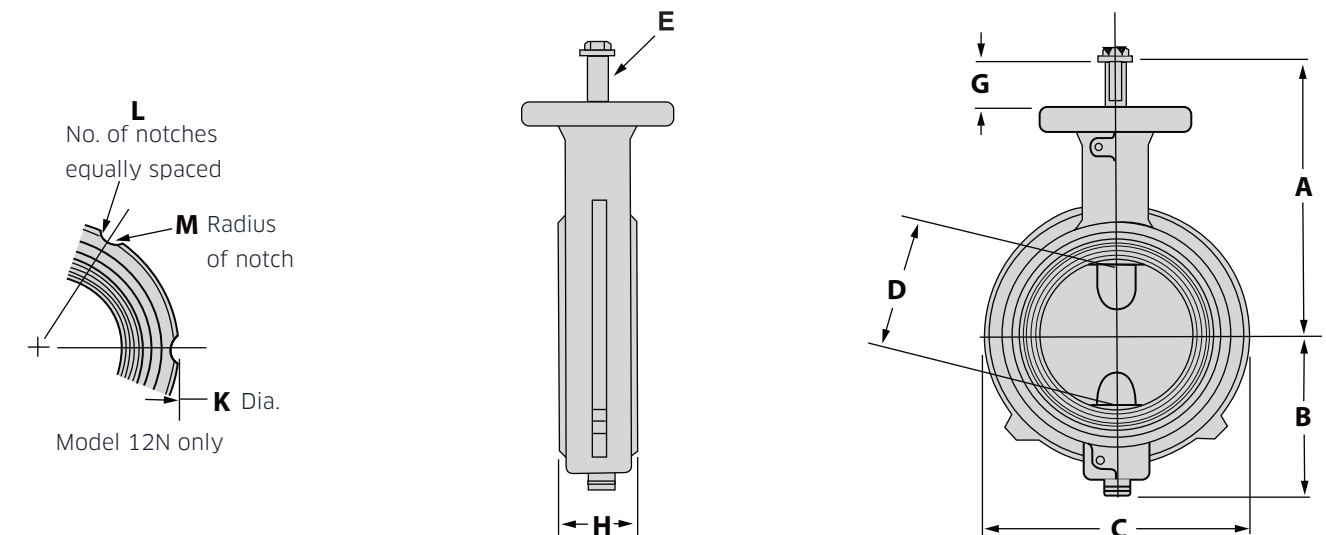

Weco® butterfly valve specifications

Model 12N (For use with lightweight industrial flanges.)

Sizes	2"	3"	4"	5"	6"	
P/N	3229885	3230052	3229886	3229887	3229888	
P/N - LT						
Dimensions, in., mm	A	4 ³ / ₂ 126	5 ² / ₂ 150	7 ¹ / ₂ 185	7 ¹ / ₂ 185	7 ² / ₂ 198
	B	3 76.2	3 ⁵ / ₁₆ 92.1	4 ¹ / ₄ 108	4 ¹ / ₁₆ 122	5 ¹ / ₁₆ 135
	C	4 ¹ / ₁₆ 105	5 ¹ / ₁₆ 137	6 ¹ / ₁₆ 175	7 ¹ / ₁₆ 197	8 ¹ / ₁₆ 222
	D	2 ¹ / ₁₆ 52.4	3 ¹ / ₁₆ 77.8	4 ¹ / ₁₆ 103	5 ¹ / ₁₆ 129	6 ¹ / ₁₆ 154
	E	³ / ₁₆ Sq. 15.9	³ / ₁₆ Sq. 15.9	³ / ₁₆ Sq. 15.9	³ / ₁₆ Sq. 15.9	³ / ₁₆ Sq. 15.9
	F	4 101.6	4 101.6	4 101.6	4 101.6	4 101.6
	G	1 ¹ / ₂ 26.2	1 ¹ / ₂ 26.2	1 ¹ / ₂ 32.5	1 ¹ / ₂ 32.5	1 ¹ / ₂ 32.5
	H	1 ¹ / ₂ 41.3	1 ³ / ₄ 44.5	2 50.8	2 ¹ / ₁₆ 54	2 ¹ / ₁₆ 54
	I	⁷ / ₁₆ 11.1	⁷ / ₁₆ 11.1	⁷ / ₁₆ 11.1	⁷ / ₁₆ 11.1	⁷ / ₁₆ 11.1
	J	3 ³ / ₄ 82.6	3 ³ / ₄ 82.6	3 ³ / ₄ 82.6	3 ³ / ₄ 82.6	3 ³ / ₄ 82.6
	K	3 ³ / ₄ 82.6	4 ³ / ₈ 111	6 ³ / ₈ 162	6 ² / ₂ 175	8 ¹ / ₂ 216
	L	4 102	6 152	6 152	6 152	8 203
	M	³ / ₁₆ 7.9	³ / ₁₆ 7.9	³ / ₁₆ 9.5	³ / ₁₆ 9.5	³ / ₁₆ 9.5

Note: - **Body:** Ductile iron **Disc:** Ductile iron **Stems:** 416 Stainless steel **Seat:** Nitrile

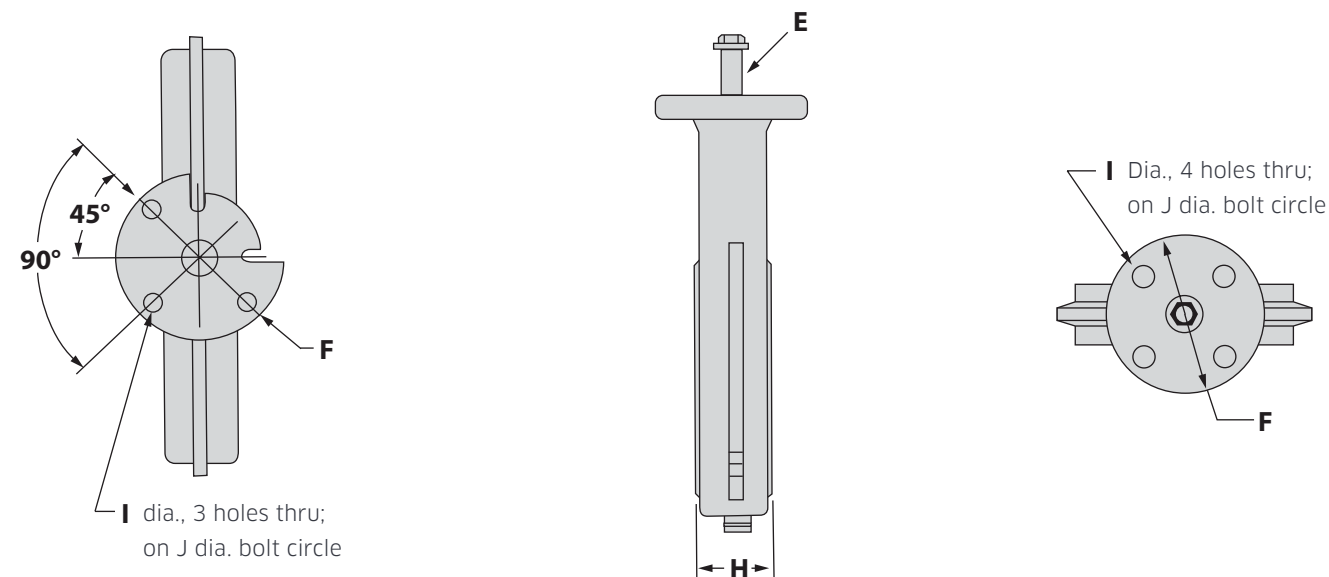

Weco® butterfly valve specifications

Model 22

Sizes	2"	2 1/2"	3"	4"	
P/N	3225730	3225731	3225732	3225733	
P/N - LT					
Dimensions, in., mm	A	7 ¹ / ₂ 185	7 ² / ₂ 198	8 ¹ / ₁₆ 205	9 ¹ / ₂ 233
	B	3 76.2	3 ¹ / ₂ 84.9	3 ³ / ₁₆ 92.1	4 ¹ / ₄ 108
	C	4 ¹ / ₁₆ 105	4 ¹ / ₁₆ 124	5 ¹ / ₁₆ 131	6 ¹ / ₁₆ 175
	D	2 ¹ / ₁₆ 52.4	2 ¹ / ₁₆ 63.5	3 ¹ / ₁₆ 77.8	4 ¹ / ₁₆ 103
	E	⁵ / ₁₆ Sq. 15.9	⁵ / ₁₆ Sq. 15.9	⁵ / ₁₆ Sq. 15.9	⁵ / ₁₆ Sq. 15.9
	F	4 101.6	4 101.6	4 101.6	4 101.6
	G	1 ¹ / ₂ 26.2	1 ¹ / ₂ 26.2	1 ¹ / ₂ 26.2	1 ¹ / ₂ 23.5
	H	1 ¹ / ₂ 41.3	1 ³ / ₄ 44.5	1 ³ / ₄ 44.5	2 50.8
	I	⁷ / ₁₆ 11.1	⁷ / ₁₆ 11.1	⁷ / ₁₆ 11.1	⁷ / ₁₆ 11.1
	J	3 ³ / ₄ 82.6	3 ³ / ₄ 82.6	3 ³ / ₄ 82.6	3 ³ / ₄ 82.6

Note: - **Body:** Ductile iron **Disc:** Ductile iron **Stems:** 416 stainless steel **Seat:** Nitrile

Model 22

5"	6"	8"	10"	12"
3225734	3225735	3225736	3225737	3225738
9 ² / ₂ 245	10 ¹ / ₂ 258	11 ¹ / ₂ 294.5	12 ² / ₂ 326	14 ¹ / ₂ 364
4 ¹ / ₁₆ 122	5 ¹ / ₁₆ 135	7 178	8 ¹ / ₁₆ 210	9 ¹ / ₁₆ 248
7 ¹ / ₁₆ 197	8 ¹ / ₁₆ 222	11 279	13 ³ / ₁₆ 340	16 ¹ / ₁₆ 408
5 ¹ / ₁₆ 129	6 ¹ / ₁₆ 154	8 ¹ / ₁₆ 205	10 254	12 305
⁵ / ₁₆ Sq. 15.9	⁵ / ₁₆ Sq. 15.9	⁵ / ₁₆ Sq. 22.2	⁵ / ₁₆ Sq. 22.2	1 ¹ / ₂ Sq. 28.6
4 101.6	4 101.6	6 152.4	6 152.4	6 152.4
1 ¹ / ₂ 32.5	1 ¹ / ₂ 32.5	1 ¹ / ₂ 32.5	1 ¹ / ₂ 32.5	1 ¹ / ₂ 32.5
2 ¹ / ₁₆ 54	2 ¹ / ₁₆ 54	2 ¹ / ₁₆ 63.5	2 ¹ / ₁₆ 63.5	3 76.2
⁷ / ₁₆ 11.1	⁷ / ₁₆ 11.1	⁷ / ₁₆ 14.3	⁷ / ₁₆ 14.3	⁷ / ₁₆ 14.3
3 ³ / ₄ 82.6	3 ³ / ₄ 82.6	5 127	5 127	5 127

Weco® butterfly valve specifications

Model 22L

Sizes	2	2½	3	4	5	6	8	
P/N	3225748	3225749	3225750	3222751	3225752	3225753	3225754	
P/N - LT								
Dimensions, in., mm	A	7½ 185	7½ 198	8⅞ 205	9½ 233	9½ 245	10½ 258	11½ 295
	B	3 76.2	3½ 84.9	3⅞ 92.1	4¼ 108	4⅞ 122	5⅞ 135	7 178
	C	6 152	7 178	7⅞ 191	9 229	10 254	11 279	13½ 343
	D	2⅞ 52.4	2½ 63.5	3⅞ 77.8	4⅞ 103	5⅞ 129	6⅞ 154	8⅞ 205
	E	¾ Sq. 15.9	¾ Sq. 15.9	¾ Sq. 15.9	¾ Sq. 15.9	¾ Sq. 15.9	¾ Sq. 15.9	¾ Sq. 22.2
	F	4 101.6	4 101.6	4 101.6	4 101.6	4 101.6	4 101.6	6 152.4
	G	1½ 26.2	1½ 26.2	1½ 26.2	1½ 32.5	1½ 32.5	1½ 32.5	1½ 32.5
	H	1⅞ 41.3	1⅞ 44.5	1⅞ 44.5	2 50.8	2⅞ 54	2⅞ 54	2⅞ 63.5
	I	⅞ 11.1	⅞ 11.1	⅞ 11.1	⅞ 11.1	⅞ 11.1	⅞ 11.1	⅞ 14.3
	J	3¼ 82.6	3¼ 82.6	3¼ 82.6	3¼ 82.6	3¼ 82.6	3¼ 82.6	5 127
	K	¾ 11	¾ 11	¾ 11	¾ 11	¾ 10	¾ 10	¾ 10
	L	4 102	4 102	4 102	8 204	8 204	8 204	8 204
	M	4¼ 121	5½ 140	6 152	7½ 191	8½ 216	9½ 241	11¼ 299

10	12	14	16	18	20	24
3225755	3225756	3255867	3255870	3255871	3255872	3255873
12⅞ 326	14½ 364	14⅞ 380	17⅞ 443	18⅞ 468	19⅞ 494	23¼ 603
8¼ 210	9¼ 248	10⅞ 264	11⅞ 303	12⅞ 329	13⅞ 354	17⅞ 435
16 406	19 483	20¼ 527	23¼ 591	25 635	27¼ 692	32 813
10 254	12 305	13¼ 337	15⅞ 388	17⅞ 439	19¼ 489	23 584
¾ Sq. 22.2	1¼ Sq. 28.6	1¼ Sq. 28.6	2* 50.8	2* 50.8	2* 50.8	2.5** 63.5
6 152.4	6 152.4	6 152.4	8 203.2	8 203.2	8 203.2	8 203.2
1½ 32.5	1½ 32.5	1½ 32.5	3⅞ 81	3⅞ 81	3⅞ 81	4⅞ 111
2½ 63.5	3 76.2	3 76.2	4 101.6	4½ 114.3	5 127	6⅞ 154
⅞ 14.3	⅞ 14.3	⅞ 14.3	⅞ 13.5	⅞ 13.5	⅞ 13.5	⅞ 16.7
5 127	5 127	5 127	6½ 165.1	6½ 165.1	6½ 165.1	6½ 165.1
⅞ 9	⅞ 9	1 8	1 8	1½ 7	1½ 7	1½ 7
12 305	12 305	12 305	16 406	16 406	20 508	20 508
14¼ 362	17 432	18¼ 476	21¼ 540	22¼ 578	25 635	29½ 750

Weco® butterfly valve specifications

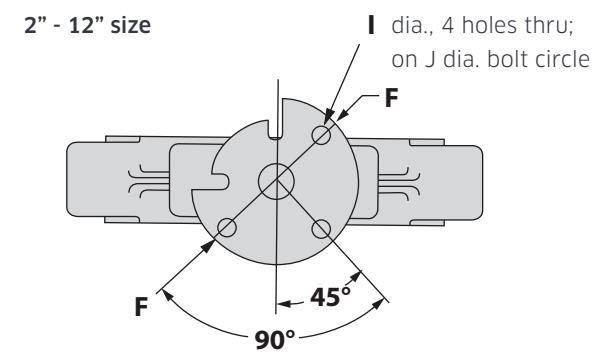
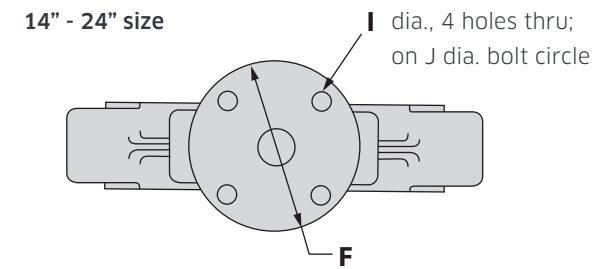
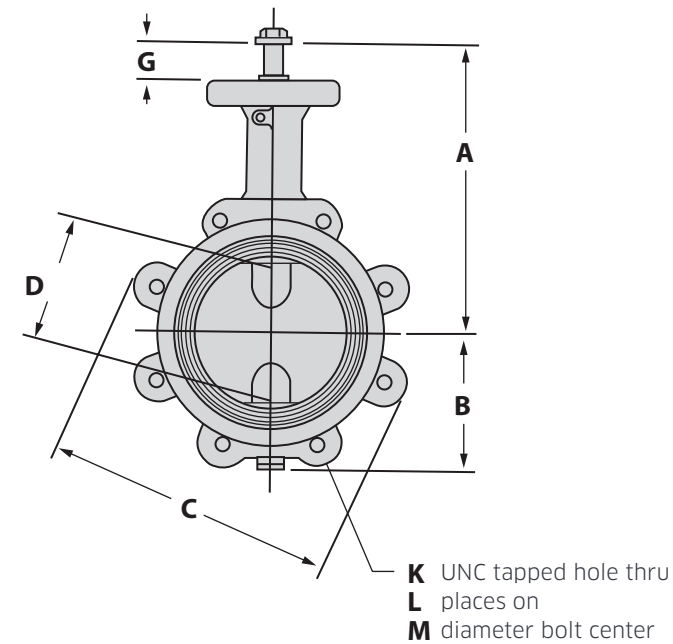

- Note:**
- **Body:** Ductile iron
 - **Disc:** Ductile iron
 - **Stems:** 416 stainless steel
 - **Seat:** Nitrile
 - * 2 inch diameter with ½ inch keyway
 - ** 2.5 inch diameter with ⅝ inch keyway

Weco® butterfly valve specifications

Standard and throttle handles

		Valve size, in.			
		2 - 3	4 and 6	8 and 10	12
Standard for models 12, 12N		3234078	3231336	3227946	3227947
Standard for models 22, 22L		3234092	3231337	3216208	3216224
Throttling for all models		3235577	3235578	3228018	3228019
Dimensions, in., mm	A	2½ 60.3	2½ 63.5	3 76.2	2½ 69.9
	B	9½ 241	10½ 276	15 381	19 483
	C	2½ 69.9	2½ 69.9	4 102	4 102
	D	1⅞ 36.5	1⅞ 42.9	1⅞ 42.9	1⅞ 42.9
	E	4 102	4 102	6 152	6 152

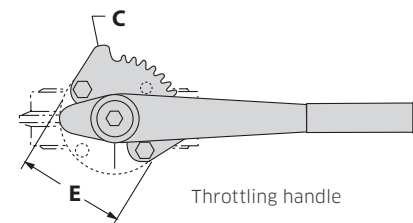
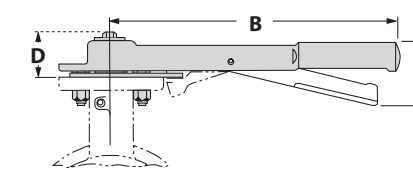
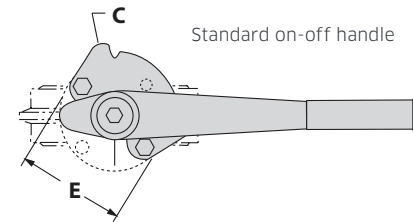

Note: - Butterfly valve assemblies include a standard detent plate for on-off operations. Handle assemblies for throttling service include a throttling detent plate to replace the standard detent plate on the valve.

Gear operators

		Valve size, in.		
		2 - 6	8 and 10	12
Standard handwheel		P561734	P561735	P561736
Dimensions, in., mm	A	2.13 54	4.07 104	4.07 104
	B	1.13 28.6	1.59 40.5	1.59 40.5
	C	6.00 152.4	9.84 249.9	9.84 249.9
	D	9.25	8.5	8.5
	E	5.53 141	7.91 201	7.91 201
	F	2.05 52	2.8 71	2.8 71
	G	8.54 216.9	10.04 255	10.91 277
	H	4.02 102	5.12 130	5.12 130
	I	-	-	-
	J	4.02 102	5.43 138	5.43 138

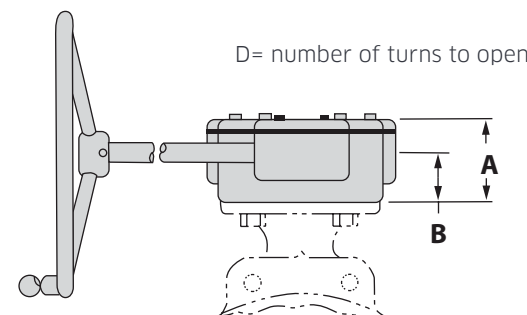
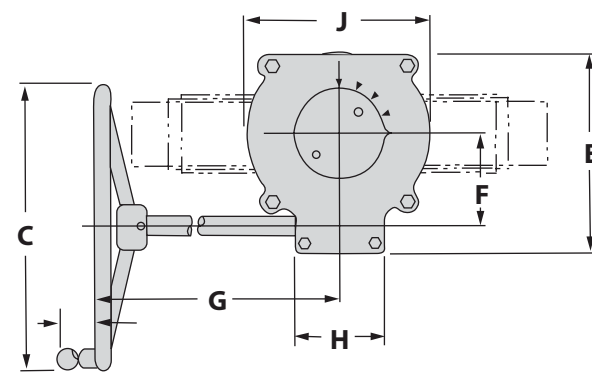

Weco® butterfly valve specifications

Sizing information

Non-compressible fluid

Use the following equations for sizing valves handling liquids

$$(A) \quad C_v = Q \sqrt{\frac{G}{\Delta P}} \quad (B) \quad Q = C_v \sqrt{\frac{\Delta P}{G}} \quad (C) \quad \Delta P = \left[\frac{Q}{C_v} \right]^2 G$$

Where: Q = Flow in gallons per minute (gpm)
 ΔP = (P₁ - P₂) Pressure Drop (psi)
 P₁ = Inlet Pressure (psia)
 P₂ = Outlet Pressure (psia)
 G = Specific Gravity of Liquid (Water = 1.0)
 C_v = Valve Coefficient (Refer To Appropriate Table)

The equations listed above are the basis for the Weco sizing nomogram. The nomogram is a method of solving the equations above quickly and simply when the service fluid is water.

C_v Values

Resilient seated BFV'S - all models

Valve size, In.	GPM @ PSI @ various disc angles								
	10°	20°	30°	40°	50°	60°	70°	80°	90°
2	1.59	6.17	14.2	26.3	44.5	70.6	105	135	159
2½	2.33	9.06	20.9	38.6	65.3	104	156	215	266
3	3.50	13.6	31.4	57.9	98.0	156	240	342	457
4	6.16	23.9	55.1	102	173	274	423	625	860
5	9.56	37.2	85.6	158	268	426	656	970	1,320
6	13.7	53.3	123	227	384	610	941	1,420	2,020
8	24.2	94.3	217	401	679	1,080	1,660	2,500	3,540
10	37.3	145	334	617	1,040	1,660	2,560	3,830	5,580
12	53.7	209	481	888	1,500	2,390	3,690	5,620	8,080
14	61	166	650	1,300	2,100	3,500	5,220	8,000	13,000
16	81	477	960	1,700	2,900	4,920	7,000	11,000	17,000
18	125	535	1,120	1,960	3,500	5,800	8,000	15,000	19,000
20	161	723	1,500	2,700	4,800	7,900	12,500	18,500	27,000
24	305	921	2,000	3,640	6,175	10,350	17,500	24,000	35,000

Example:

Given: A 6" Weco Butterfly Valve is to be installed in a line handling 500 gpm of water.

Find: Maximum pressure drop across the valve when in the full open and 60° open positions.

Solution: This problem may be solved using the nomogram or equation (C).

First using the nomogram: Enter nomogram on right side for a flow rate of 500 gpm. Draw horizontal line until it intersects the 6" valve line. From this point draw a vertical line until it intersects the 90° open line. Project line horizontally to the left and read ΔP of .061 psi. Now, using same procedure as above, extend vertical line to 60° open line and project horizontally to the left to read ΔP of .67 psi for 60° open.

Using equation (C): Pressure Drop = $\Delta P = \left[\frac{Q}{C_v} \right]^2 G$

Where: C_v = 2020 @ 90° open (from tables)
 G = 1.0 (Water)
 Q = 500 gpm

$$\Delta P = 1.0 \left[\frac{500}{2020} \right]^2 = .0613$$

Now: C_v = 610 gpm @ 60° open, and

$$\Delta P = 1.0 \left[\frac{500}{610} \right]^2 = .672$$

Weco® butterfly valve specifications

Nomogram for sizing Weco butterfly valves

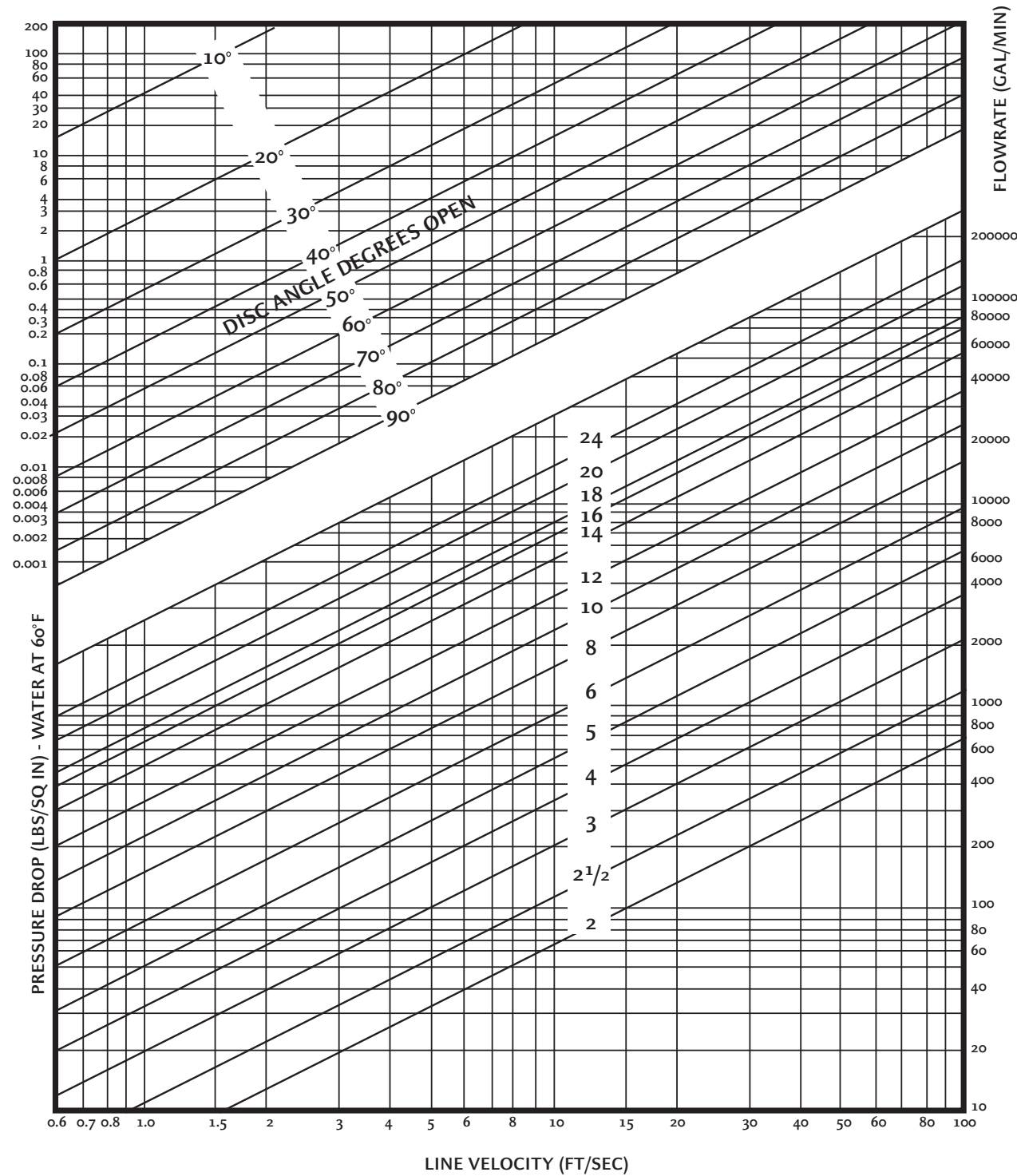

Weco® butterfly valve specifications

Pneumatic actuators - double acting

Model	330	350	550	550A	590	590A	
Sizes, in.	2 - 6	5 - 6	8 - 10	12	10	12	
Part #	3235438	3237369	3236771	3237183	3237886	3237887	
Weight	lb	12	20	38	38	67	67
	kg	5.1	9	18	18	31	31
A	in.	12 ¹ / ₁₆	16 ¹ / ₁₆	19 ¹ / ₁₆	19 ¹ / ₁₆	22	22
	mm	319	511	492	492	559	559
B	in.	8 ³ / ₄	12 ³ / ₁₆	13 ¹ / ₁₆	13 ¹ / ₁₆	15 ¹ / ₁₆	15 ¹ / ₁₆
	mm	222	313	348	348	403	403
C	in.	3 ³ / ₁₆	3 ³ / ₁₆	5 ³ / ₁₆	5 ³ / ₁₆	5 ³ / ₁₆	5 ³ / ₁₆
	mm	84.1	84.1	133	132	132	139
D	in.	7 ¹ / ₁₆	7 ¹ / ₁₆	12 ¹ / ₁₆	12 ¹ / ₁₆	12 ¹ / ₁₆	12 ¹ / ₁₆
	mm	198	198	308	308	308	308
E	in.	1 ¹ / ₁₆	1 ¹ / ₁₆	3 ³ / ₁₆	3 ³ / ₁₆	3 ³ / ₁₆	3 ³ / ₁₆
	mm	49.2	49.2	90.5	90.5	81	81
F	in.	2 ¹ / ₁₆	2 ¹ / ₁₆	3 ¹ / ₁₆	3 ¹ / ₁₆	3 ¹ / ₁₆	3 ¹ / ₁₆
	mm	52.4	52.4	77.8	77.8	77.8	77.8
G	in.	2	3 ³ / ₁₆	3 ³ / ₁₆	3 ³ / ₁₆	5 ¹ / ₁₆	5 ¹ / ₁₆
	mm	50.8	84.1	84.1	84.1	135	135
H	in.	3 ³ / ₈	6 ¹ / ₂	6 ¹ / ₂	6 ¹ / ₂	10 ³ / ₁₆	10 ³ / ₁₆
	mm	98.4	165.1	165	165	268	268
J	in.	4 ³ / ₁₆	4 ³ / ₁₆	5 ³ / ₁₆	5 ³ / ₁₆	5 ³ / ₁₆	5 ³ / ₁₆
	mm	110	110	135	135	135	135
K	in.	1 ¹ / ₁₆	1 ¹ / ₁₆	1 ¹ / ₈	1 ¹ / ₈	1 ¹ / ₈	1 ¹ / ₈
	mm	36.5	36.5	47.6	47.6	47.6	47.6
L	in.	16 UNC	16 UNC	13 UNC	13 UNC	13 UNC	13 UNC
	mm	3 ³ / ₄	3 ³ / ₄	5	5	5	5
M	in.	82.6	82.6	127	127	127	127
	mm	15.9	15.9	22.2	28.6	22.2	28.6

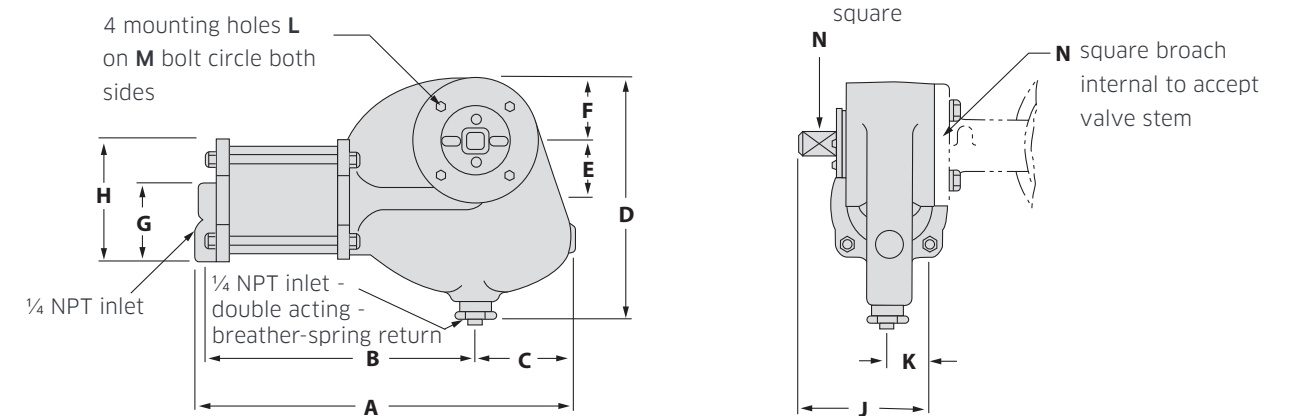

Weco® butterfly valve specifications

Pneumatic actuators - spring acting

Model	332	333	354	355	596	597A	
Sizes, in.	2 - 3	3 - 4	4	5 - 6	8 - 10	12	
Part #	3237525	3237368	3237373	3237515	3237865	3237866	
Weight	lb	17	19	29	35	112	125
	kg	7.5	8.5	13	16	51	57
A	in.	19 ¹⁶ / ₁₆	19 ¹⁶ / ₁₆	20 ⁴ / ₁₆	20 ⁴ / ₁₆	30 ⁰ / ₁₆	30 ⁰ / ₁₆
	mm	497	497	514	514	765	765.2
B	in.	15 ³ / ₁₆	15 ³ / ₁₆	16 ⁷ / ₁₆	16 ⁷ / ₁₆	24	24
	mm	400	400	418	418	610	610
C	in.	3 ³ / ₁₆	3 ³ / ₁₆	3 ³ / ₁₆	3 ³ / ₁₆	5 ¹ / ₁₆	5 ¹ / ₁₆
	mm	84.1	84.1	84.1	84.1	129	132
D	in.	8 ⁸ / ₁₆	8 ⁸ / ₁₆	8 ⁸ / ₁₆	8 ⁸ / ₁₆	13 ³ / ₁₆	13 ³ / ₁₆
	mm	219	219	219	219	333	333
E	in.	1 ¹ / ₁₆	1 ¹ / ₁₆	1 ¹ / ₁₆	1 ¹ / ₁₆	3 ³ / ₁₆	3 ³ / ₁₆
	mm	49.2	49.2	49.2	49.2	81	81
F	in.	2 ² / ₁₆	2 ² / ₁₆	2 ² / ₁₆	2 ² / ₁₆	3 ³ / ₁₆	3 ³ / ₁₆
	mm	52.4	52.4	52.4	52.4	77.8	77.8
G	in.	2	2	3 ³ / ₁₆	3 ³ / ₁₆	5 ¹ / ₁₆	5 ¹ / ₁₆
	mm	50.8	50.8	84.1	84.1	135	135
H	in.	3 ³ / ₁₆	3 ³ / ₁₆	6 ¹ / ₁₆	6 ¹ / ₁₆	10 ⁰ / ₁₆	10 ⁰ / ₁₆
	mm	98.4	98.4	165	165	268	268
J	in.	4 ⁴ / ₁₆	4 ⁴ / ₁₆	4 ⁴ / ₁₆	4 ⁴ / ₁₆	5 ¹ / ₁₆	5 ¹ / ₁₆
	mm	110	110	110	110	135	135
K	in.	1 ¹ / ₁₆	1 ¹ / ₁₆	1 ¹ / ₁₆	1 ¹ / ₁₆	1 ¹ / ₁₆	1 ¹ / ₁₆
	mm	36.5	36.5	36.5	36.5	47.6	47.6
L	in.	¾	¾	¾	¾	½	½
	mm	16 UNC	16 UNC	16 UNC	16 UNC	13 UNC	13 UNC
M	in.	3 ³ / ₄	3 ³ / ₄	3 ³ / ₄	3 ³ / ₄	5	5
	mm	82.6	82.6	82.6	82.6	127	127
N	in.	¾	¾	¾	¾	¾	1 ¹ / ₁₆
	mm	15.9	15.9	15.9	15.9	22.2	28.6

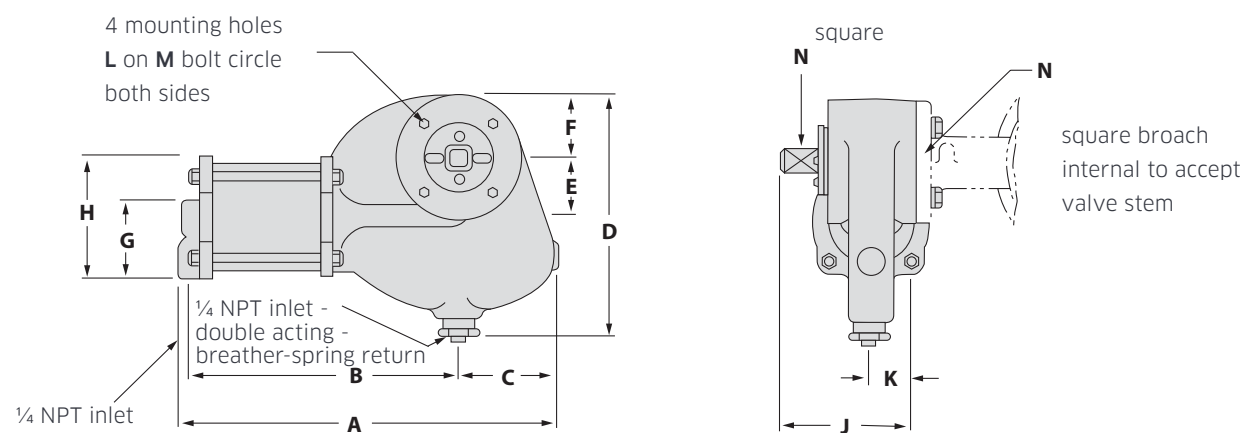

Weco® butterfly valve specifications

Weco® actuator sizing specifications

Required operating torques:

There are three torques to be considered when selecting the proper actuator for a butterfly valve:

- ▶ **Seating torque** - The torque required to displace a resilient seat and effect shutoff
- ▶ **Bearing torque** - The torque required to overcome friction forces on the valve shaft bearing surfaces
- ▶ **Dynamic torque** - Torque due to fluid forces which tend to close the valve

in most general butterfly valve applications. Where unusual service conditions exist (such as likelihood of seat swelling, or low and high temperature seat hardening), an additional safety factor may be applicable.

Dynamic torque

Dynamic torque is torque on the valve shaft due to the fluid forces on the valve disc. This torque is a function of valve diameter, pressure drop, and a torque coefficient (**C_t**) which varies with angle opening. Torque is calculated by the equation:

The torques for resilient seated valves tabulated in this section are the sum of **(1)** and **(2)** above for various shutoff pressures. These tabulated values include a safety factor large enough to insure proper valve operation

$T = C_t D^3 \Delta P$

Where: T = Dynamic torque (in-lb)
D = Valve Dia (in.)
C_t = Dynamic torque coefficient (see table below)

C _t vs. Angle open										
Angle open	0	10	20	30	40	50	60	70	80	90
C _t	0	.007	.014	.022	.033	.050	.087	.143	.215	0

Valve Part	Standard Material	Optional Materials
Seat & O-ring	Nitrile (Buna N) (-20°F to 200°F)	Hypalon®, Polytetrafluoroethylene (PTFE), Viton®, EPDM, Red Natural Rubber
Body	Ductile Iron	Aluminum, Steel, Stainless Steel
Stem (upper & lower)	410 Stainless Steel	316 Stainless Steel
Disc	Ductile Iron	Aluminum, Bronze, 316 Stainless Steel, Ryton®, Kynar®, Halar, Polytetrafluoroethylene (PTFE) Coated, Nickle Plated, Hastelloy®
Spirol/Retainer Pins	302 Stainless Steel	

Weco® butterfly valve specifications

Weco® actuator sizing information

Dynamic torque is not usually of major concern in resilient seated butterfly valves unless the line velocity exceeds 20 fps. If line velocity exceeds this, a check should be made to insure that actuator output exceeds the calculated dynamic torque. Dynamic torque should be checked at 80° open for on-off applications.

Dynamic torque is of prime consideration in situations where line velocity is not recovered downstream of the valve. This situation exists on installations where there is an unlimited source and less than 6 diameters of pipe downstream of the valve. If a valve discharges to the atmosphere, the pressure drop across the valve will be equal to the height of water above the valve for all angles of valve opening. This pressure drop must not exceed the pressure drop tabulated in Maximum ΔP vs. Angle Opening Tables for any angle. If it does, provisions must be made for velocity recovery by adding downstream piping.

Actuator sizing for tee linkages:

For standard tee linkage applications where one actuator operates two butterfly valves of the same size with one valve opening as the other valve closes, the actuator sizing will be the same as for a single butterfly valve application. For the actuator sizing for other tandem linkage applications, consult the factory.

Low-torque valves:

Undercut discs are available for butterfly valve applications that require lower seating torques. For complete information, consult factory.

Actuators sizing torque for Weco® butterfly valves

Valve size, in.	Seating torque in Inch-lb (N*m), @ various line pressures						
	0 psi	50 psi	75 psi	100 psi	125 psi	150 psi	175 psi
	0 kPa	345 kPa	517 kPa	690 kPa	862 kPa	1034 kPa	1207 kPa
2	90	90	92	94	96	98	100
	10	10	10	11	11	11	11
2½	130	130	134	138	142	146	150
	15	15	15	15	16	17	17
3	200	200	206	212	218	224	230
	23	23	23	24	25	25	26
4	350	350	366	382	398	414	430
	23	40	41	43	45	47	49
5	535	535	566	597	628	659	690
	60	60	64	67	71	74	78
6	770	770	823	876	929	982	1,035
	87	87	93	99	105	111	117
8	1,350	1,350	1,475	1,600	1,725	1,850	1,975
	153	153	167	181	195	209	223
10	2,100	2,100	2,340	2,580	2,820	3,060	3,300
	237	237	264	292	319	346	373
12	3,000	3,000	3,400	3,800	4,200	4,600	5,000
	339	339	384	429	475	520	565
14	3,680	4,240	4,790	5,350	5,900	6,480	–
	416	479	541	605	667	732	–
16	4,880	5,730	6,580	7,430	8,280	9,140	–
	551	647	744	840	936	1030	–
18	6,230	7,460	8,690	9,920	11,150	12,390	–
	704	843	982	1121	1260	1400	–
20	7,770	9,380	11,000	12,610	14,230	15,840	–
	878	1060	1243	1425	1610	1790	–
24	11,100	14,010	16,920	19,830	22,740	25,650	–
	1250	1580	1910	2240	2570	2900	–

Note:

- For valves using Polytetrafluoroethylene (PTFE) seats, use torque value at highest standard value rating even for lower pressure applications.
- Above figures are for valves used in wet service, for dry service valves contact factory.

Weco® butterfly valve specifications

Weco® actuator sizing specifications

Minimum air pressure for Weco® pneumatic actuators operating Weco® valves at 175 psi rated pressure

Double acting models	Actuator air pressure: psi (kPa)		
	30	50	75
	207	345	517
Valve sizes			
330	2" - 4"	2" - 5"	2" - 6"
350	2" - 6"	2" - 6"	2" - 6"
550	8"	8" - 10"	8" - 10"
550A	–	–	12"
590	8" - 10"	8" - 10"	8" - 10"
590A	12"	12"	12"

Spring return models	Actuator air pressure: psi (kPa) *Note			
	30 (207)	40 (276)	60 (414)	70 (483)
	40 (276)	50 (345)	70 (483)	80 (552)
Valve sizes				
332	2" - 2½"	2 - 2½"	2 - 2½"	2 - 2½"
333	–	–	–	2" - 4"
354	2" - 4"	2" - 4"	2" - 4"	2" - 4"
355	–	–	2" - 6"	2" - 6"
596	–	8" - 10"	8" - 10"	8" - 10"
597A	–	–	12"	12"

Note:

- Pressure above line for air to open, spring to close. Below line for air to close, spring to open.
- All of the above ratings are conservative for normal installations. Abnormally high torque conditions may necessitate increased actuator capability.
- Maximum actuator air pressure 120 psi, except 80 psi maximum pressure on Models 350, 590 and 590A.

Weco® pneumatic actuator torque ratings (note the air pressure)

Double acting models	Displacement cu. in. cu. cm	Rated torque in. lb N*m	Pressure to achieve rated torque psi kPa
330	25	1,150	80
	410	130	552
350	72	1,150	30
	1180	130	207
550	120	5,500	80
	1970	622	552
550A	120	5,500	80
	1970	622	552
590	355	5,500	30
	5820	622	207
590A	355	5,500	30
	5820	622	207

Note:

- All of the above ratings are for normal installations.
- Abnormally high torque conditions may necessitate increased actuator air pressure.

Torque data

Pressure	psi	40	60	80	100	120
	kPa	276	414	552	690	827
Torque output	in. lb	800	1,200	1,600	2,000	2,400
	mm kg	90	136	181	226	271

Spring return models	Displacement cu. in. cu. cm	Spring closing torque in. lb N*m	Spring opening torque in. lb N*m	Air opening torque @ 80 psi in. lb N*m	Air closing torque @ 80 psi in. lb N*m
332	25	150	300	1,000	850
	410	17	34	113	96
354	25	425	850	725	300
	40	48	96	82	34
596	72	425	850	2,641	2,216
	1180	48	96	298	250
550A	72	1,050	2,100	2,016	966
	1180	119	237	228	109
590	355	3,300	6,600	11,366	8,066
	5820	373	746	1280	911
590A	355	5,000	10,000	9,666	4,666
	5820	565	1130	1100	527

Minimum actuator pressure for Weco valves at 175 psi line pressure

Valve size	2" - 4"	5"	6"	
Pressure	psi	30	45	60
	kPa	207	310	414

Original Chiksan® swivel joints

Chiksan swivel joints deliver significantly longer life, superior performance, and reduced maintenance. Designed for standard and sour gas services, these world proven fittings come in 3/8 to 12-inch sizes and can handle pressures from vacuum to 20,000 psi. Many different Chiksan assembly configurations are available. These styles can be combined in an unlimited variety of ways to suit practically any installation. Available end connections are threaded, integral Weco® wing union, beveled for welding, or flanged. Like all pressure containing products, Chiksan swivels require special handling. **(See warnings and cautions, pg. 88).**

1. Steamlined bore minimizes flow restrictions

Smooth, round bore design minimizes turbulence and pressure drop, Longsweep and TripleStep swivel joints have extra-long radius elbows that optimize flow characteristics and extend life in the ball race areas when handling abrasives at extremely high pressures.

2. Proven packing design

Industry leading packing design integrates an anti-extrusion ring that serves as a retainer and bearing to reduce friction between the resilient packing material and the packing chamber as the joint is rotated.

3. Bearings key to rotation, strength

To assure long, dependable service, Chiksan dual and tri-race ball bearing swivels are designed to meet or exceed load capacities and service conditions. All ball races are either flame hardened, carburized and hardened, or have “snap-in” stainless steel ball races.

4. Field repairable

If packing, bearings, or ball plugs should need replacing, easy-to-use field repair kits are available.

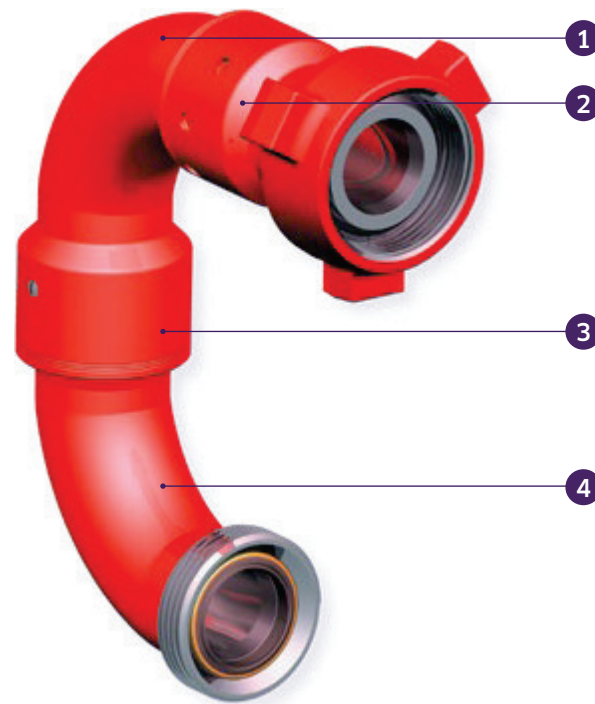

Swivel Family	Color coding	Cold working pressure psi (bar)	Material	End connections	Nominal sizes, In.								Notes	
					3/8	1/2	1	1 1/4	1 1/2	2	3	4		
High-pressure swivel joints	Silver	6,000 (414)	Carbon steel	Female line pipe threads	▶	▶	▶	▶	▶	▶	▶	▶	▶	1,3,5
Low-pressure swivel joints	No color coding	600 (41)	Ductile Iron	Threaded		▶	▶	▶	▶	▶	▶	▶	▶	6
		175 (12)	Ductile Iron	Flanged							▶	▶	6	
		1,000 (69)	Carbon Steel	Threaded or beveled							▶	▶	▶	6
		275 (19)	Carbon Steel	Flanged							▶	▶	▶	6
Longsweep® swivel joints	Olive green (sour gas)	7,500 (517)	Alloy steel	Weco figure 1002 union								▶		2
	Olive green (sour gas)	10,000 (690)	Alloy steel	Weco figure 1502 union			▶				▶	▶		2
	Black	10,000 (690)	Alloy steel	Female line pipe threads			▶				▶			1,3,4
	Olive green (sour gas)	15,000 (1034)	Alloy steel	Weco figure 2202 union							▶	▶		2
	Red	15,000 (1034)	Alloy steel	Weco figure 1502 union			▶				▶			1
	Light blue	20,000 (1034)	Alloy steel	Weco figure 2002 union							▶			1
TripleStep swivel joints	Silver	6,000 (414)	Alloy steel	Weco figure 602 union								▶		1
	Black	10,000 (690)	Alloy steel	Weco figure 1002 union								▶	▶	1
	Red	15,000 (1034)	Alloy steel	Weco figure 1502 union								▶	▶	1
	Light blue	20,000 (1034)	Alloy steel	Weco figure 2002 union								▶		1
TripleStep Plus swivel joints	Red	15,000 (1034)	Alloy steel	Weco figure 1505 union								▶		1

- 3/8 - to 4-inch sizes furnished with nitrile packing and brass or stainless steel anti-extrusion ring.
- Furnished with Fluoroelastomer or HNBR packing and stainless steel anti-extrusion ring. TechnipFMC does not warrant the performance of any elastomer seal for sour gas service.
- Power make-up must be used for line pipe threaded connections to achieve rated cold working pressure.
- 3-inch size rated at 10,000 psi cold working pressure with integral Weco® 1002 union ends only.
- 5-inch size available with threaded or bevelled ends; limited to 3,000 psi cold working pressure.
- 3/4, 2 1/2, 6 and 8-inch sizes also available.

Sour gas service:

TechnipFMC manufactures Chiksan sour gas swivel joints in accordance with the National Association of Corrosion Engineers (NACE) Standard MR-01-75 and the American Petroleum Institute's (API) Standard RP-14-E. These swivel joints are specially heat-treated and inspected for controlled hardness. Because the specially heat treated steel required for sour gas service does not provide a strong enough bearing surface, Chiksan sour gas swivel joints use patented snap-in ball races to assure extra strength and high load-bearing capacity. Fluoroelastomer or HNBR packing is used to isolate the races from the line fluid.

- All body materials meet ASTM or AISI standards.
- Consult factory for special sizes, styles, end connections, or packing units.

TripleStep swivel joints

Designed especially for abrasive, high pressure well servicing applications, TripleStep swivel joints have been proven against competitive swivels in customer-witnessed flow loop tests and field applications. The patented three step ball race design provides significantly greater erosion allowance without increasing swivel joint size or weight. The result: TripleStep swivel joints deliver increased life, superior performance, and reduced maintenance...lasting 1.7 to 5 times longer than competitive swivels.

1. Exclusive design delivers longer life, lower cost

TripleStep swivel joints deliver the highest bending and axial load capacities in the industry. They also eliminate rejections from excessive wear in the ball race areas as well as swivel seizures due to corrosion and brinnelling of the ball races.

2. Advanced material selection

The TripleStep swivel joint is manufactured from forged alloy steel with a closely controlled, proprietary chemical composition and heat treatment to ensure superior toughness, ductility, case depth, case hardness, and core strength.

3. Instream packing for long seal life

World proven instream packing technology provides unsurpassed sealability and reliability in the harshest oilfield conditions. An integral anti-extrusion ring serves as a retainer and bearing to reduce friction between the resilient packing material and the packing chamber as the joint is rotated.

4. Unmatched erosion allowance

Patented three step design coupled and bearing race geometry adds significant wall thickness under the male races and bearing load capacity without increasing swivel joint size or weight.

5. Eliminates routine maintenance

An improved environmental seal reduces the potential for corrosion in the ball race area. The integrity of the seal and the use of a high-performance grease during initial assembly virtually eliminates the need for periodic greasing.

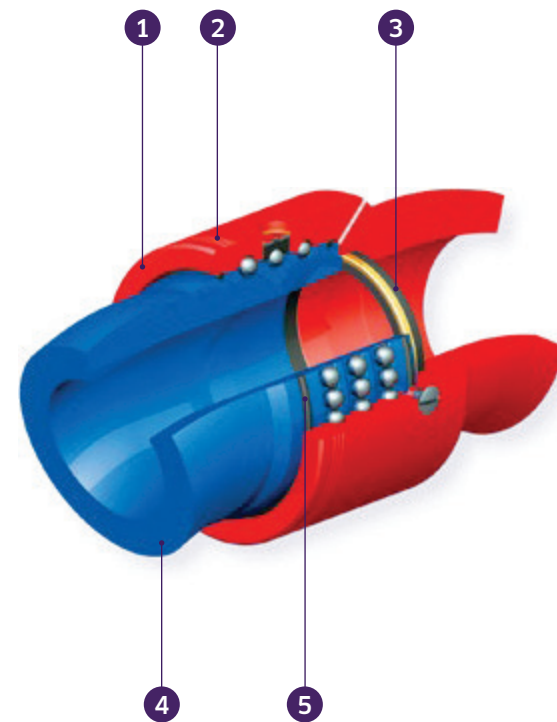

TSi+(TripleStep) swivel joints

The TSi+ adds a second seal which significantly extends the swivel life, customers have seen over one year of intensive use without disassembly, by stopping aggressive flow and internal erosion due to failure of the primary seal.

- ▶ 6,000 psi cold working pressure; 3 inch.
- ▶ 10,000 psi cold working pressure; 3 inch.
- ▶ 15,000 psi cold working pressure; 3 inch.

Recommended service

For the most extreme, abrasive, high-pressure points in fracturing, choke-and-kill, cementing or acidizing applications.

TSi (TripleStep) swivel joints

Recommended service

Long-radius elbows designed especially for high-pressure abrasive applications such as fracturing, choke-and-kill lines, cementing and circulating hoses, acidizing, and test lines.

- ▶ 6,000 psi cold working pressure; 3 inch size.
- ▶ 10,000 psi cold working pressure; 3 and 4-inch sizes.
- ▶ 15,000 psi cold working pressure; 3 and 4 inch.
- ▶ 20,000 psi cold working pressure; 3 inch size.

Thicker where it counts

Competitive swivels wear out first in the ball races, meaning they must be disassembled for inspection. TripleStep swivels wear in the elbows, meaning they can be inspected and returned to service without disassembly. The TripleStep design places more material under the male ball race - a location that computational fluid dynamic analysis and field testing shows to be a high erosion area.

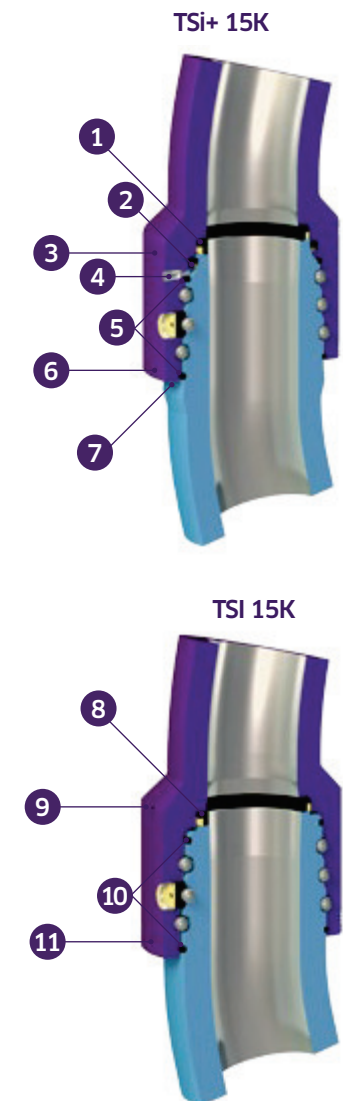

TSi+

1. Primary packing
2. Second primary S-seal packing
3. 2 marks on bell front = 2 seals
4. Weep hole
5. O-ring
6. 3 marks on bell end = triple step
7. 2 marks on male = 2 seals

TSi

8. Primary packing
9. Weep hole
10. O-ring
11. 3 marks on bell end = triple step

TSi and TSi+ will not be cross assembled

Accelerated wear test
(40ft/sec. with 6 ppa 20/40 northern sand)

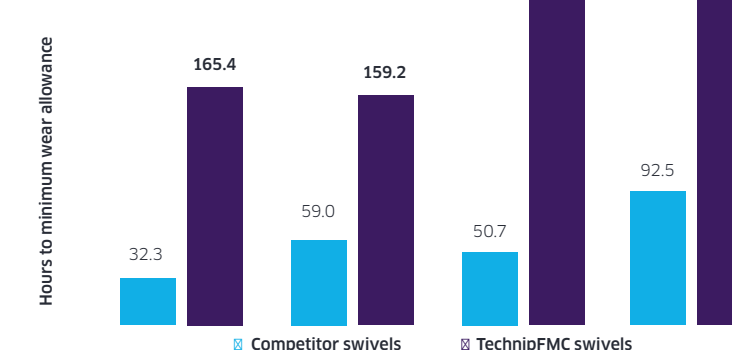

Chiksan sour gas swivel joint

TechnipFMC manufactures Chiksan sour gas swivel joints in accordance with the National Association of Corrosion Engineers (NACE) Standard MR-01-75 and the American Petroleum Institute's (API) Standard RP-14-E.

These swivel joints are specially heat-treated and inspected for controlled hardness. Because the specially heat-treated steel required for sour gas does not provide a hard enough bearing surface, Chiksan sour gas swivel joints use snap-in ball races for extra strength and high load-bearing capacity. Sour gas swivel joints come standard with integral Weco® wing union end connections.

They also have a leak-detection port between the packing and the O-ring seal. If leakage past the packing should occur, it is forced through the port, signaling the need for packing replacement. For positive identification, all Chiksan sour gas swivel joints are stamped "Sour Gas" or "NACE MR-01-75" using low-stress dot stamping and painted with an olive green, zinc-chromate primer that is unique to sour gas equipment.

1. Controlled hardness

Swivel components are specially heat-treated and 100% tested for controlled hardness.

2. Positive identification

Chiksan swivels for sour gas service are stamped "Sour Gas" and painted with an olive green, zinc-chromate primer to ensure quick, positive identification.

3. Leak detection

A leak detection port between the packing and O-ring seal signals the need for packing replacement.

4. Snap-in ball races

Snap-in ball races provide hard bearing surface to deliver extra strength and high load-bearing capacity when handling sour gas.

5. Proven packing design

Elastomeric packing with stainless steel anti-extrusion ring and secondary O-ring seal are used to isolate the races and bearings from line fluid.

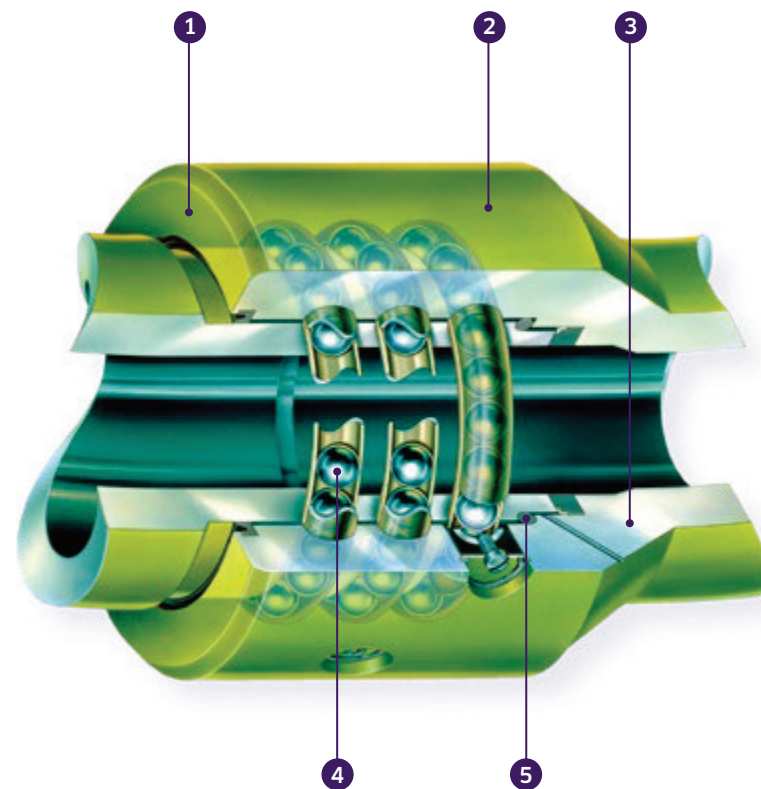

Chiksan Swivel Joint Styles

Chiksan swivel joints are available from stock in nine basic styles or configurations. These styles permit 360-degree rotation and movement in one, two, or three planes. They can be combined in an unlimited variety of ways to suit practically any installation. All Chiksan swivel joints are assembled using two or more standard pieces.

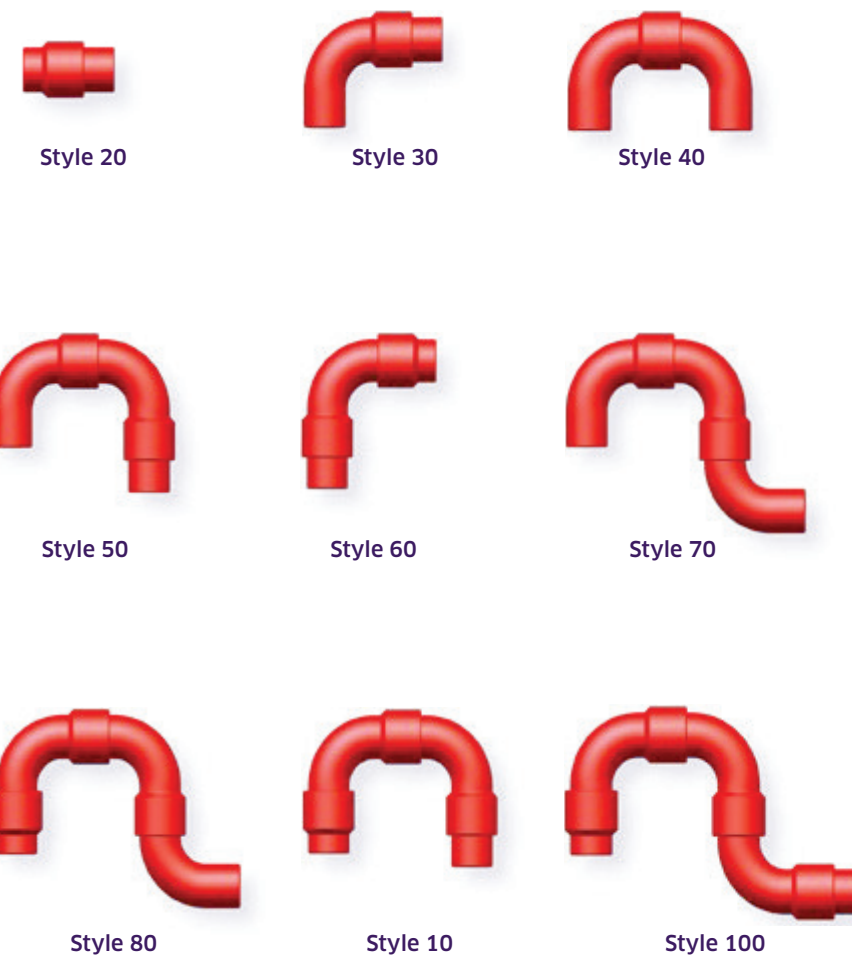

Chiksan swivel joints for sour gas service

6,000 psi cold working pressure; 3/8 to 4-inch sizes

Longsweep swivel joints

- ▶ 7,500 psi cold working pressure, 3-inch size; Weco Figure 1002 wing union end connections
- ▶ 10,000 psi cold working pressure, 1,2,3 and 4-inch sizes; Weco Figure 1502 wing union end connections
- ▶ 15,000 psi cold working pressure, 2 and 3-inch sizes; Weco Figure 2202 wing union end connections
- ▶ 20,000 psi cold working pressure, 2-inch size; Weco Figure 2002 wing union end connections

Warning: Although Chiksan swivel joints can be rotated while under fluid pressure, they are not recommended for service requiring continuous rotary motion. **See warnings and cautions, pg 88.**

See specifications tables (pgs. 39-45 for sizes, dimensions, weights, materials, and part numbers.

Chiksan cementing and circulating hoses

Chiksan cementing and circulating hoses can handle a complete range of standard and sour gas fluids at cold working pressures up to 15,000 psi. These rugged, all-steel hoses are available in 1 to 3-inch sizes and configurations to meet virtually any need. All materials meet ASTM or AISI standards.

Recommended service

High-pressure discharge lines, water lines, temporary flow lines, well testing lines, cementing and circulating lines, and other high-pressure applications.



Features

- ▶ All designs feature Chiksan swivel joints which provide flexibility, absorb shock and vibration, and maximize flow characteristics
- ▶ Weco wing union connections ensure fast, pressure-tight make-up and break-out without threading, welding, or special connections
- ▶ Chiksan hoses fold up easily and quickly for transportation and storage
- ▶ Designs are available for sour gas services at cold working pressures up to 15,000 psi

Chiksan coiled tubing reel swivel

15,000 psi cold working pressure; 2 and 3-inch sizes

Recommended service

High-pressure coiled tubing applications

1. Reliable UV packing

With zero failures in thousands of high-pressure gate valve stem seal applications worldwide, proprietary UV packing provides greater sealability with lower torque than comparable seals.

2. Converts for sour gas service

By changing out the Weco® wing union subs, the assembly is converted to a sour gas swivel. This exclusive feature reduces inventory and lowers costs.

3. Fast, easy field maintenance

The swivel internal components can be serviced from the front without removing the housing from the coiled tubing unit.

4. Stepped bearing races

Exclusive stepped bearing race geometry enables easy centering of the mandrel relative to the packing. Stepped design also provides low bearing stresses and torque for longer bearing life.



Consult factory for special coiled tubing applications.

See specifications tables (pgs. 39-45) for sizes, dimensions, weights, and materials.

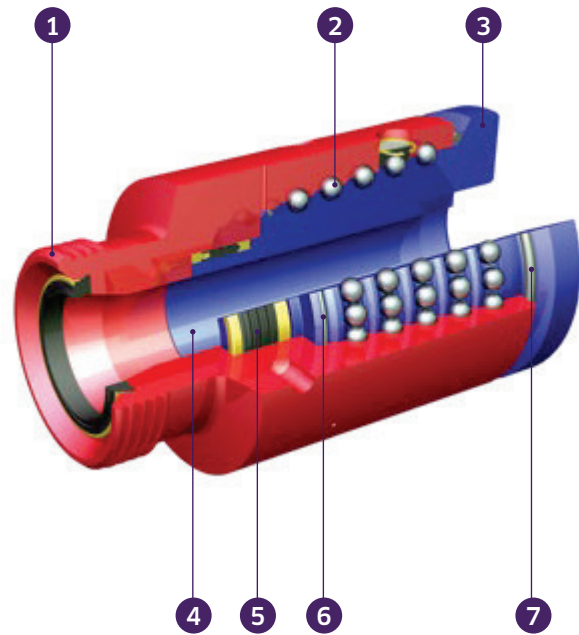

Chiksan coiled tubing frac swivel

10,000 psi cold working pressure; 2 5/16 inch bore

Recommended service

High pressure coiled tubing well fracturing application.

Features

- ▶ 10,000 psi cold working pressure
- ▶ Temperature ratings from -20°F to 225°F
- ▶ Maximum rotational speed of 10 rpm

1. 3 inch 15K Wing union connection
2. Patented stepped ball bearing race handles load at full working pressure under rotation
3. Flanged end connection with optional Grayloc™ clamp
4. Smooth straight through-bore greatly reduced erosion in well fracturing applications
5. Patented and field proven UV-packing seal all non-elastomeric stack or hybrid packing stack used optional low cost all elastomeric packing available
6. Leak detection seal
7. Environment seal

Chiksan® swivel joint specifications

TripleStep and Longsweep® swivel joints

Size/model bore in. (mm)	CWP psi bar	End connections	Style 20			Style 30			
			Part No.	A in. mm	lb kg	Part No.	A in. mm	B in. mm	lb kg
1" LS10 .88 (22)	10,000 690	Threaded	CF*	-	-	6101537	4.38 111	7.14 181	8 3.6
		1502 (MxF)	CF*	-	-	3259291	4.06 103	8.4 213	14 6.3
1.5" LS15 1.3 (33)	15,000 1034	1502 (MxM)	CF*	-	-	N/A	-	-	-
		Threaded	CF*	-	-	CF*	-	-	-
1.5" LS10 1.3 (33)	10,000 690	1502 (MxF)	CF*	-	-	CF*	-	-	-
		1502 (MxM)	CF*	-	-	N/A	-	-	-
2" LS10 1.88 (48)	10,000 690	Threaded	CF*	-	-	3139889	6.38 162	9.01 228.854	21 9.5
		1502 (MxF)	3144126	11.15 283	31 14	3144125	5.5 139.7	10.91 277.12	36 17
		1502 (MxM)	CF*	-	-	N/A	-	-	-
2" LS15 1.88 (48)	15,000 1034	1502 (FxM)	CF*	-	-	-	-	-	-
		1502 (MxM)	CF*	-	-	-	-	-	-
2" LS20 1.88 (48)	20,000 1379	2002 (MxF)	CF*	-	-	CF*	-	-	-
		2002 (MxM)	P524579	14.12 359	45.72 20.7	CF*	-	-	-
3" TSi15 2.75 (70)	7,500 517	Threaded	CF*	-	-	N/A	-	-	-
3" TSi17 2.75 (70)	15,000 1034	1502 (FxM)	P505417	12.6 320	52 23.8	P505416	7.9 201	14.4 366	68 31
		1502 (MxM)	CF*	-	-	N/A	-	-	-
3" TSi15 Plus 2.75 (70)	15,000 1034	1505 (MxF)	CF*	-	-	N/A	-	-	-
3" TSi20 3 (76)	20,000 1379	2002 (MxF)	CF*	-	-	CF*	-	-	-
4" TSi10 3.88 (98)	10,000 690	1002 (MxF)	P516092	14.15 359	74 33.6	P517487	8.3 211	16.2 411	99 45
		1002 (MxM)	CF*	-	-	N/A	-	-	-
4" TSi15 3.5 (89)	15,000 690	1502 (MxF)	CF*	-	-	CF*	-	-	-

*Consult factory

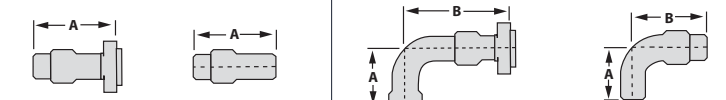

See specifications tables (pgs. 39-45) for sizes, dimensions, weights, and materials..

Chiksan® swivel joint specifications TripleStep and Longsweep® swivel joints

Style 40				Style 50					Style 60			
Part No.	A in. mm	B in. mm	lb kg	P/N P/N-LT	A in. mm	B in. mm	C in. mm	lb kg	Part No.	A in. mm	B in. mm	lb kg
N/A	-	-	-	3139546	4.38 111	7.28 185	7.02 178	16 7.2	CF*	-	-	-
N/A	-	-	-	3139547	4.06 103	7.35 187	8.4 213	22 10.2	CF*	-	-	-
N/A	-	-	-	N/A	-	-	-	-	-	-	-	-
N/A	-	-	-	3139777	5.62 143	9.37 238	7.96 203	21 9.2	CF*	-	-	-
N/A	-	-	-	3139778	5 127	9.4 239	10.1 257	36 17	CF*	-	-	-
N/A	-	-	-	N/A	-	-	-	-	CF*	-	-	-
3139890	6.36 162	10.73 273	29.8 13.5	3139904	6.4 163	10.74 273	9 229	37 16.8	CF*	-	-	-
N/A	-	-	-	3139475 3139475-LT	5.5 140	10.74 273	10.92 277	52 24	3144630	11 279	11 279	48 22
N/A	-	-	-	3267203	7.28 185	10.74 273	10.92 277	63 29	6101559	11 279	11 279	56 26
N/A	-	-	-	P509888	5.5 140	10.74 273	8.79 223	40 19	P504952	8.79 223	10.97	37 16.9
N/A	-	-	-	3144569	5.12 130	10.9 277	12.51 318	62 28.3	CF*	-	-	-
N/A	-	-	-	N/A	-	-	-	-	CF*	-	-	-
N/A	-	-	-	N/A	-	-	-	-	CF*	-	-	-
N/A	-	-	-	P505327	7.9 201	16.4 417	14.4 366	107 48.4	P505420	14.5 368	14.5 368	91 41.3
N/A	-	-	-	N/A	-	-	-	-	CF*	-	-	-
N/A	-	-	-	P563781	7.9 201	16.4 417	14.4 366	114 52	CF*	-	-	-
N/A	-	-	-	P527340	9.69 246	21.2 538	20.4 518	288 131	CF*	-	-	-
N/A	-	-	-	P516091	8.3 211	18.1 460	16.2 411	161 73.3	CF*	-	-	-
N/A	-	-	-	N/A	-	-	-	-	CF*	-	-	-
N/A	-	-	-	P527331 P527331-LT	9.69 246	21.2 538	20.4 518	255 116	CF*	-	-	-

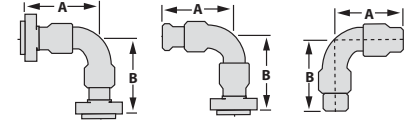
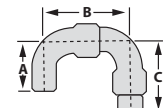
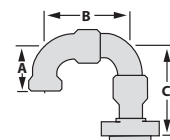
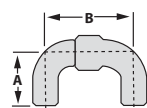

*Consult factory

Chiksan® swivel joint specifications TripleStep and Longsweep® swivel joints

Size/model bore in. (mm)	CWP psi bar	End connections	Style 70					
			Part No.	A in. mm	B in. mm	C in. mm	D in. mm	lb kg
1" LS10 .88 (22)	10,000 690	Threaded	N/A	-	-	-	-	-
1" LS15 .88 (22)	15,000 1034	1502 (MxF)	N/A	-	-	-	-	-
		1502 (MxM)	N/A	-	-	-	-	-
1.5" LS10 1.3 (33)	10,000 690	Threaded	N/A	-	-	-	-	-
1.5" LS15 1.3 (33)	15,000 1034	1502 (MxF)	N/A	-	-	-	-	-
		1502 (MxM)	N/A	-	-	-	-	-
2" LS10 1.88 (48)	10,000 690	Threaded	3139891	6.38 162	10.73 273	10.73 273	6.38 162	47 21.2
2" LS15 1.88 (48)	15,000 1034	1502 (MxF)	P505482	5.5 140	10.73 273	10.73 273	5.5 140	58 27
		1502 (MxM)	N/A	-	-	-	-	-
		1502 (FxF)	N/A	-	-	-	-	-
2" LS20 1.88 (48)	20,000 1379	2002 (MxF)	N/A	-	-	-	-	-
		2002 (MxM)	N/A	-	-	-	-	-
3" TSi15 2.75 (70)	7,500 517	Threaded	N/A	-	-	-	-	-
3" TSi15 2.75 (70)	15,000 1034	1502 (MxF)	N/A	-	-	-	-	-
		1502 (MxM)	N/A	-	-	-	-	-
3" TSi15 Plus 2.75 (70)	15,000 1034	1505 (MxM)	N/A	-	-	-	-	-
3" TSi20 3 (76)	20,000 1379	2002 (MxF)	N/A	-	-	-	-	-
4" TSi10 3.88 (98)	10,000 690	1002 (MxF)	N/A	-	-	-	-	-
		1002 (MxM)	N/A	-	-	-	-	-
4" XHTL 3.5 (89)	10,000 690	1502 (MxF)	N/A	-	-	-	-	-

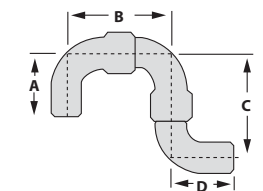

Chiksan® swivel joint specifications

TripleStep and Longsweep® swivel joints

Style 80						Style 10					Style 100					
Part No.	A in. mm	B in. mm	C in. mm	D in. mm	lb kg	Part No.	A in. mm	B in. mm	C in. mm	lb kg	Part No.	A in. mm	B in. mm	C in. mm	D in. mm	lb kg
CF*	-	-	-	-	-	3141454	7.14 181	7.46 189	7.14 181	24 10.9	N/A	-	-	-	-	-
P516135	8.4 181	7.47 190	7.47 190	4.06 103	28 12.9	3139550	8.4 213	7.4 188	8.4 213	22 10	CF*	-	-	-	-	-
N/A	-	-	-	-	-	3145886	8.4 213	7.4 188	8.4 213	27 12.1	CF*	-	-	-	-	-
CF*	-	-	-	-	-	P501542	7.96 202	9.37 238	7.96 202	26 11.8	N/A	-	-	-	-	-
P502504	10.12 257	9.37 238	9.37 238	5 127	45 21	3139781	10.12 257	9.37 238	10.12 257	42 20	CF*	-	-	-	-	-
N/A	-	-	-	-	-	3139780	10.12 257	9.37 238	10.12 257	52 23.5	CF*	-	-	-	-	-
3139892	8.91 226	10.73 273	10.73 273	6.38 162	56 25.6	3139476	9 229	10.7 272	9 229	45 20.5	N/A	-	-	-	-	-
3139901	10.9 277	10.73 256	10.73 256	5.5 140	68 31	3139905	10.9 277	10.7 272	10.9 277	63 29	3144094	10.97 279	10.73 273	10.73 273	10.91 277	79 36
P527697	10.9 277	10.7 272	10.7 272	7.3 186	79 36	3139477	10.9 277	10.7 272	10.9 277	72 33	3139903	10.97 279	10.73 273	10.73 273	10.91 277	88 40
N/A	-	-	-	-	-	P518960	8.8 224	10.7 272	10.9 277	52 24	CF*	-	-	-	-	-
CF*	-	-	-	-	-	3144570	10.85 275.59	10.85 275.59	12.51 318	78 35.2	CF*	-	-	-	-	-
N/A	-	-	-	-	-	3144571	12.46 316.48	10.85 275.59	12.52 318	87 39.5	3144572	12.5 318	10.9 277	10.9 277	12.5 318	108 49.1
N/A	-	-	-	-	-	P524218	12.88 327	16.42 417	12.88 327	102 46.4	CF*	-	-	-	-	-
P505409	14.4 366	16.4 417	16.4 417	7.9 201	145 65.9	P505325	14.5 368	16.4 417	14.4 366	129 58.7	P505410	14.4 366	16.4 417	16.4 417	14.6 371	168 76.1
N/A	-	-	-	-	-	P505326	14.4 366	16.4 417	14.4 366	143 64.8	P505411	14.4 366	16.4 417	16.4 417	14.6 371	181 82.2
N/A	-	-	-	-	-	-	-	-	-	-	P562241	14.4 366	16.4 417	16.4 417	14.6 371	198 90
CF*	-	-	-	-	-	P516094	16.1 409	18.1 460	16.2 411	198 89.8	CF*	-	-	-	-	-
N/A	-	-	-	-	-	P516093	15.9 404	18.1 460	16.2 411	209 95	CF*	-	-	-	-	-
CF*	-	-	-	-	-	3130501	20.4 518	21.2 538	20.4 518	338 154	CF*	-	-	-	-	-

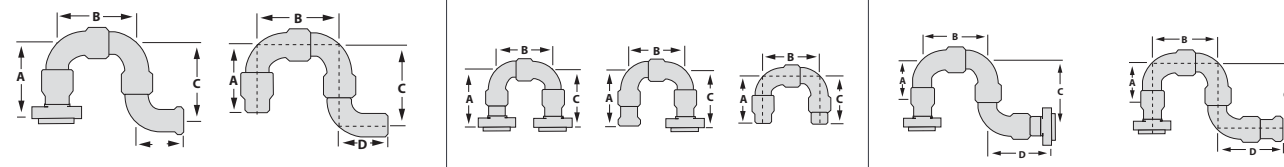

*Consult factory

Chiksan® swivel joint specifications

High-pressure swivel joints

Nom. sizes in.	CWP psi bar	Ends	Style 20			Style 30			Style 40			Style 50						
			Part No.	A in. mm	lb kg	Part No.	A in. mm	B in. mm	lb kg	Part No.	A in. mm	B in. mm	lb kg	Part No.	A in. mm	B in. mm	C in. mm	lb kg
.38	6,000	Threaded	3111290	3.31	1.5	3111291	1.94	2.81	1.8	3111292	2.0	1.94	2	3111293	1.94	2.88	2.81	3.3
	414			84	0.7		49	71	0.8		49	54	49		73	71	1.5	
.5	6,000	Threaded	3111314	3.31	1.5	3111315	1.94	2.81	1.8	3111316	2.0	1.94	2	3111317	1.94	2.88	2.81	3.3
	414			84	0.7		49	71	0.8		49	54	49		73	71	1.5	
.75	6,000	Threaded	3220946	5.19	3.6	3220947	2.72	4.62	4.39	3220948	2.72	2.72	4.5	3220883	2.72	4.22	4.62	7.2
	414			131	1.63		69	117	1.99		69	2	69		107	117	3.24	
1	6,000	Threaded	3207727	5.19	3.16	3207728	2.72	4.62	3.6	3207729	2.72	2.72	4.5	3205399	2.72	4.22	4.62	6.8
	414			131	1.43		69	117	1.6		69	2	69		107	117	3.1	
1.25	6,000	Threaded	3207734	5.47	4	3207735	3.19	4.72	6.8	3207736	3.19	4.28	6.3	3207737	3.19	4.28	4.72	8
	414			139	1.8		81	120	3.10		81	109	2.8		81	109	120	3.6
1.5	6,000	Threaded	3207741	5.47	10	3207743	3.19	4.72	6.2	3207744	3.19	4.28	7.9	3205400	3.19	4.28	4.72	10
	414			139	4.5		81	120	2.80		81	109	3.58		81	109	120	4.5
2	6,000	Threaded	3207749	6.66	13	3207750	4.03	5.84	16	3207751	4.03	5.88	19.5	3205637	5.84	5.88	4.03	27
	414			169	5.5		102	148	6.8		102	149	8.9		148	149	102	12.3
2.5	6,000	Threaded	CF*	8.25	18	-	-	-	-	3221068	4.88	7.68	29	3219959	7.12	7.68	4.88	37
	414			210	8.2		124	195	13.2		181	195	124		16.8			
3	6,000	Threaded	3207756	9.12	30	3207757	4.62	9.44	37	3207758	4.62	8.75	43	3207759	4.62	7.94	8.62	53
	414			232	14		117	240	16.8		117	222	20		117	202	219	24.1
4	6,000	Threaded	3207764	9.59	42	3207765	5.56	10.81	57	3207766	5.56	10.56	64	3207767	5.56	9.83	9.88	90
	414			244	19		141	275	26		141	268	29.1		141	250	251	41

*Consult factory

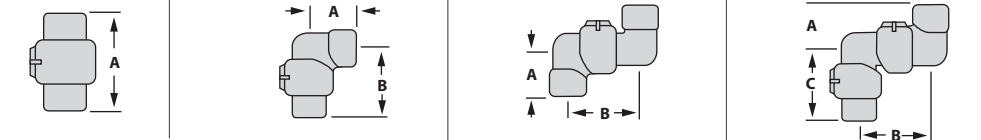

Chiksan® swivel joint specifications

High-pressure swivel joints

Nom. sizes in.	CWP psi bar	Ends	Style 60			Style 70			Style 80				Style 10							
			Part No.	A in. mm	lb kg	Part No.	A in. mm	B in. mm	lb kg	Part No.	A in. mm	B in. mm	C in. mm	lb kg	Part No.	A in. mm	B in. mm	C in. mm	lb kg	
.38	6,000 414	Threaded	3111294	2.81 71	2.8 1.3	CF*	-	-	-	N/A	-	-	-	-	N/A	-	-	-	-	
.5	6,000 414	Threaded	3111318	2.81 71	2.8 1.3	CF*	-	-	-	3111320	1.94 49	2.88 73	2.81 71	4.8 2.2	3111313	3.12 79	2.88 73	3.12 79	4 1.8	
.75	6,000 414	Threaded	3220949	4.62 117	5.8 2.6	CF*	-	-	-	3220952	2.72 69	4.22 107	4.62 117	10 4.5	3220951	4.62 117	4.22 107	4.62 117	9 4.1	
1	6,000 414	Threaded	3207730	4.62 117	8.8 4		3207731	2.72 69	4.22 107	8 3.6	3207732	2.72 69	4.22 107	4.62 117	10 4.5	3207726	4.62 117	4.22 107	4.62 117	9 4.1
1.25	6,000 414	Threaded	3207738	4.72 120	8.9 4.03		3207739	3.19 81	4.28 109	9.4 4.3	3207740	3.19 81	4.28 109	4.72 120	12 5.2	3207733	4.72 120	4.28 109	4.72 120	14 5.9
1.5	6,000 414	Threaded	3207745	4.72 120	8.2 3.72		3207746	3.19 81	4.28 109	9.4 4.3	3207747	3.19 81	4.28 109	4.72 120	14 6.4	3207741	4.72 120	4.28 109	4.72 120	10 4.5
2	6,000 414	Threaded	3207752	5.84 148	22 9.7		3207753	4.03 102	5.88 149	29 13	3207754	4.03 102	5.88 149	5.84 148	38 17.3	3207748	5.84 148	5.88 149	5.84 148	33 15
2.5	6,000 414	Threaded	N/A	-	-		N/A	-	-	-	N/A	-	-	-		N/A	-	-	-	-
3	6,000 414	Threaded	3207760	8.62 219	48 21.8		3207761	4.62 117	7.94 202	57 25.9	3207762	4.62 117	7.94 202	9.44 240	77 35	3207762	8.62 219	7.94 202	9.44 240	77 34.9
4	6,000 414	Threaded	3207768	9.88 251	73 33.2		3207769	5.56 141	9.62 244	98 45	3207763	5.56 141	9.62 244	10.81 275	111 50.3	3207763	9.88 251	10.31 262	10.81 275	111 50.2

*Consult factory

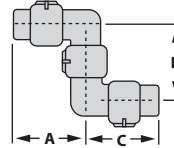
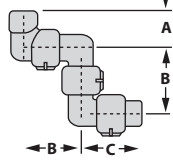
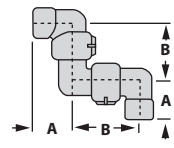
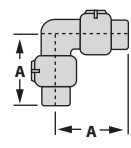

Chiksan® cementing and circulating hoses

TripleStep and Longsweep® swivel joints

Nominal Size/model	Color code	Cold working pressure psi bar	Weco fig. No.	Swivel joint styles #1 / #2	Method of construction					
					Length in extended condition, weight					
					Threaded 10 ft		Threaded 12 ft		Integral 9.5 ft*	
Part No.	lb kg	Part No.	lb kg	Part No.	lb kg					
1" HP	Silver	6,000 414	602	50 / 50	3211995	37 17	3207644	41 19	N/A	-
1 - 1/2" HP	Silver	6,000 414	602	50 / 50	3206211	86 39	3205870	76 34.5	N/A	-
1 - 1/2" LS	Black	10,000 690	1502	50 / 50	3264538 3264538-LT	62.9 28.5	3254780 3254780-LT	114 52	N/A	-
	Red	15,000 1034	1502	50 / 50	N/A	-	N/A	-	3267266	134 61
2" HP	Silver	6,000 414	602	50 / 50	3206495	122 56	3205876	134 61	N/A	-
2" LS	Black	10,000 690	1502	50 / 50	3144394 3144394-LT	142 65	3144001 3144001-LT	156 71	N/A	-
	Red	15,000 1034	1502	50 / 10	N/A	-	N/A	-	6102805 6102805-LT	152 68.9
2" LSG	Olive green (sour gas)	10,000 690	1502	50 / 10	N/A	-	N/A	-	6102809	155 70
3" HP	Silver	6,000 414	602	50 / 50	3247975	253 115	3231262	234 106	N/A	-

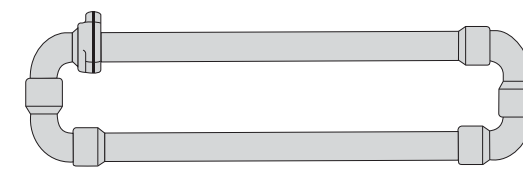

Typical integral construction

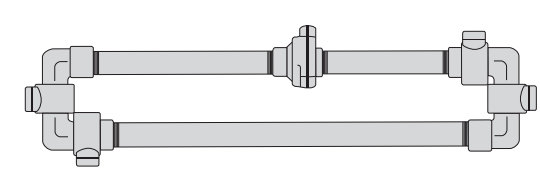

Typical threaded construction

Original Weco® wing unions

Weco® wing unions are the most complete line of standard and sour gas service pipe connectors in the world.

Available in 1 to 12-inch nominal pipe sizes with cold working pressures up to 20,000 psi, Weco® wing unions are manufactured using the finest raw materials, tooling procedures, and heat-treating techniques available. Materials meet ASME and AISI standards. Each union is carefully inspected to ensure long, dependable service in the most extreme conditions. Like all pressure containing products, Weco® wing unions require special handling. (See Warnings, page 66).

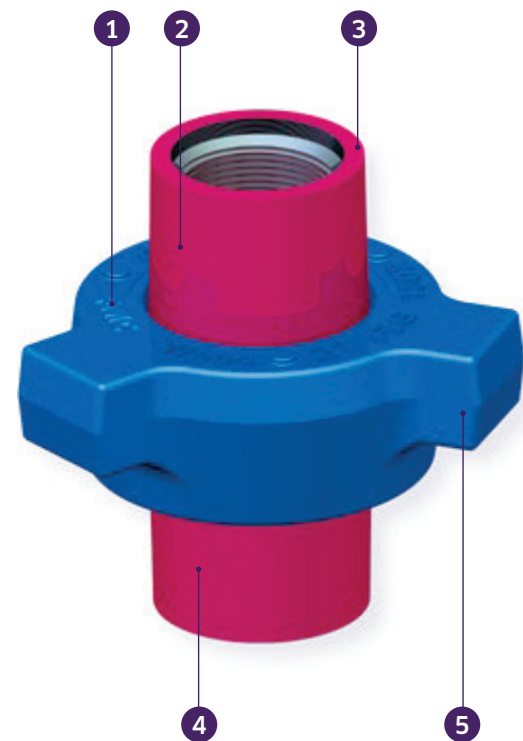

- 1. Positive identification**
For positive identification in the field, all Weco® wing union nuts and subs include the Weco® name union figure number, size, and pressure rating. Additionally, for sour gas service are stamped "Sour Gas."
- 2. Simple identification**
New, factory-shipped Weco® wing unions are color coded for quick identification.
- 3. Choice of end connections**
Weco® wing unions are available with line pipe or tubing threads, butt-weld, or non-pressure seal end connections.
- 4. Interchangeable parts**
All Weco® wing union parts of the same figure number, size, and pressure rating are interchangeable. This feature makes it easy to mate male and female subs that are frequently made-up and broken-out.
- 5. Fast make-up, break-out**
Three lug nuts and self-locking ACME threads provide fast make-up and break-out regardless of position or space restrictions.

Proven seal designs

Pressure rating shown for integral and non-threaded end configuration. May be derated for threaded end configuration.

Low-pressure services (1,000 to 2,000 psi)

Weco® wing unions for low-pressure services feature a primary metal-to-metal seal. The spherical surface of the male sub and conical surface of the female sub provide a large, ball-and-cone sealing surface. This metal-to-metal seal remains leak-proof even when one surface is slightly pitted or misaligned.

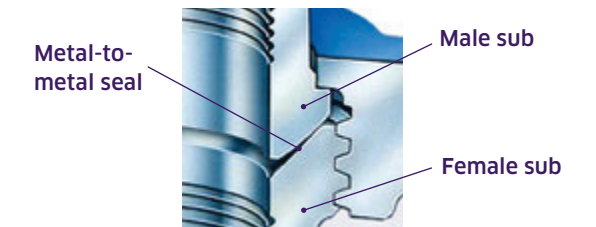

Medium-pressure services (2,000 to 4,000 psi)

Many Weco® wing union designs supplement the metal-to-metal seal with a resilient O-ring in the male sub. The replaceable O-ring extends union life and protects the metal-to-metal seal against corrosion.

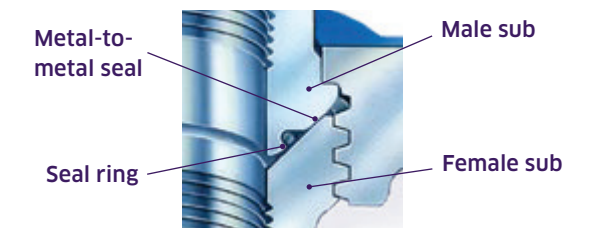

High-pressure services (6,000 to 20,000 psi)

Weco® wing unions for high-pressure services feature a replaceable, lip-type seal ring in the female sub. This primary seal protects the secondary metal-to-metal seal from abrasion and corrosion while minimizing flow turbulence.

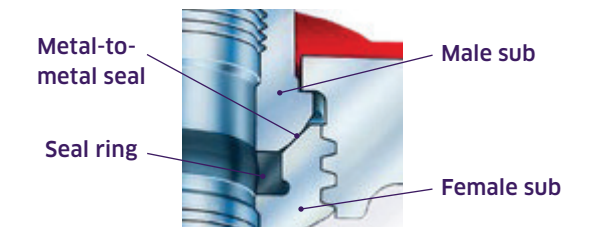

NPS (non-pressure seal) (Option Figures 602, 1002, and 1502)

The Weco® non-pressure seal option is especially designed for abrasive, high-pressure wing union services where welded connections are undesirable. This design provides strong, permanent end connections without butt-welding. The union ends are shop assembled to pipe or tubing. An epoxy thread compound is used to secure the connection.

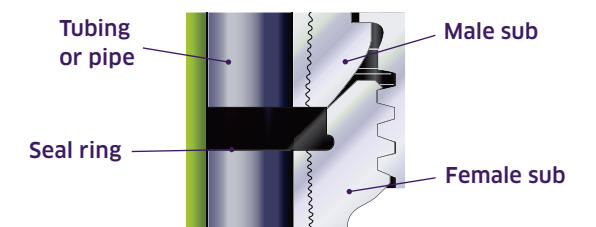









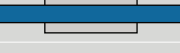
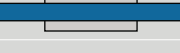
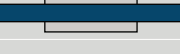

Warning

Interchangeable parts

Weco® wing union parts of the same figure number, size and pressure rating are interchangeable, making it easy to match male and female subs that are frequently made-up and broken-out. For positive identification in the field, all Weco® wing union nuts and subs include the Weco® name, figure number, size, and pressure rating. It is vital that the user positively identify union connections and components to avoid mismatch conditions and potential union failure.

Wing Unions

Figure No.	Assembly color key standard service	Pressure rating, psi, bar				Nominal pipe sizes, inches			Notes
		Standard		Sour gas (see note 8)		1 25	1¼ 32	1½ 40	
		Cold working	Test	Cold working	Test				
100		1,000 69	1,500 103	N/A	N/A				
200		2,000 138	3,000 207	N/A	N/A	▶	▶	▶	1
206		2,000 238	3,000 207	N/A	N/A	▶	▶	▶	1
207		2,000 138	3,000 207	N/A	N/A				1
400		2,500 172	3,750 259	2,500 172	3,750 259				
400		4,000 276	6,000 414	4,000 276	6,000 414				1,4
602		6,000 414	9,000 621	6,000 414	9,000 621	▶	▶	▶	1,2
1002		10,000 690	15,000 1034	7,500 517	11,250 776	▶	▶	▶	1,2,3,9
1003		10,000 690	15,000 1034	7,500 517	11,250 776				1,3,10
1502		15,000 1034	22,500 1551	10,000 690	15,000 1034	▶		▶	1,2,3
1505		15,000 1034	22,500 1551	10,000 690	15,000 1034				11
2002		20,000 1379	30,000 2068	N/A	N/A				7
2202		N/A	N/A	15,000 1034	22,500 1551				7

* N/A - Not Available

* All end connections with line pipe threads unless otherwise noted.

1. Butt-weld available. Consult factory for wall thickness.
2. Non-pressure seal configurations available.
3. Power make-up must be used for line pipe threaded connections to achieve rated cold working pressure.
4. Line pipe threads are not offered for sour gas service in this figure number.
5. Line pipe threads are not recommended for sour gas service above 4-inch nominal pipe size.
6. Figure 400 available in 5 1/2 - and 7-inch OD with casing threads.
7. Available in butt-weld ends only.
8. All unions for sour gas service are painted olive green, stamped "SOUR GAS" or "NACE MR-01-75" and have specially modified material properties.
9. 5 and 6-inch sizes rated at 7,500 psi CWP and 11,250 test; 5 and 6-inch unions for sour gas service rated at 5,000 psi CWP and 7,500 psi test.
10. 4 and 5-inch sizes rated at 7,500 psi CWP and 11,250 test; 4 and 5-inch unions for sour gas service rated at 5,000 psi CWP and 7,500 psi test.
11. Available as integral end connection only.

Nominal pipe sizes, inches									Notes
2 50	2½ 65	3 80	4 100	5 125	6 150	8 200	10 250	12 300	
▶	▶	▶	▶		▶	▶			
▶	▶	▶	▶						1
▶	▶	▶	▶		▶	▶	▶		1
		▶	▶		▶	▶	▶		1
				▶	▶	▶		▶	1,5,6
▶	▶	▶	▶						1,4
▶	▶	▶	▶						1,2
▶	▶	▶	▶	▶	▶				1,2,3,9
▶		▶	▶	▶					1,3,10
▶	▶	▶	▶						1,2,3
		▶							11
▶		▶							7
▶		▶							7

Sour Gas TechnipFMC manufactures Weco® sour gas unions in accordance with the National Association of Corrosion Engineers (NACE) Standard MR-01-75 and American Petroleum Institute's (API) Standard RP-14-E.

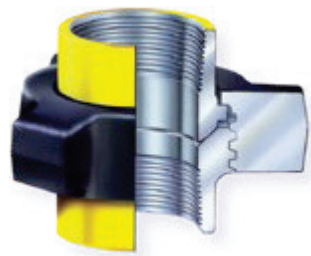

Figure 100

1,000 psi cold working pressure

Recommended service

Manifold and line connections

Features

- ▶ Pressure-tight make-up with hammer
- ▶ Economical low-pressure union

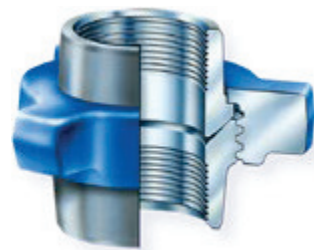

Figure 200

2,000 psi cold working pressure

Recommended service

General service manifolds and lines

Features

- ▶ Pressure-tight make-up with hammer
- ▶ Economical low-pressure union

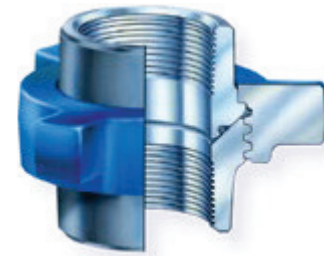

Figure 206

2,000 psi cold working pressure

Recommended service

Manifold line connections, suction service, and corrosion service

Features

- ▶ O-ring in male sub improves sealing and protects metal-to-metal seal against corrosion
- ▶ Replaceable O-ring extends union service life
- ▶ 1 to 10-inch sizes

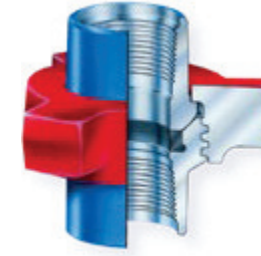

Figure 1002

10,000 psi cold working pressure through 4-inch sizes; 7,500 psi cold working pressure, 5 and 6-inch sizes

Recommended service

Cementing, fracturing, acidizing, testing, and choke-and-kill lines

Features

- ▶ O-ring in male sub improves sealing and protects metal-to-metal seal against corrosion
- ▶ Replaceable O-ring extends union service life
- ▶ 1 to 10-inch sizes



Figure 1003

10,000 psi cold working pressure, 2 and 3-inch sizes; 7,500 psi cold working pressure, 4 and 5-inch sizes

Recommended service

For high-pressure connections where lines cannot be aligned

Features

- ▶ Ball seat provides positive seal with up to 7-1/2° misalignment; 2-inch model up to 4°
- ▶ Replaceable O-ring on male sub provides primary seal
- ▶ Available with threaded or butt-weld ends

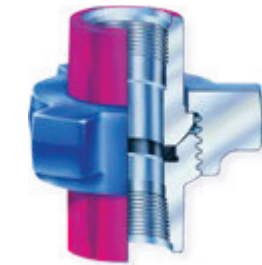

Figure 1502

15,000 psi cold working pressure

Recommended service

Cementing, fracturing, acidizing, testing, and choke-and-kill lines

Features

- ▶ Replaceable, lip-type seal
- ▶ Available for sour gas service: 10,000 psi cold working pressure; butt-weld or non-pressure seal configurations only
- ▶ Butt-weld available



Figure 207

2,000 psi cold working pressure

Recommended service

Seals manifold connections and protects union threads

Features

- ▶ Parts interchangeable with Figures 200 and 206
- ▶ O-ring on blanking cap ensures a leak-free seal
- ▶ Cap can be tapped for pressure gauge
- ▶ Available in butt-weld

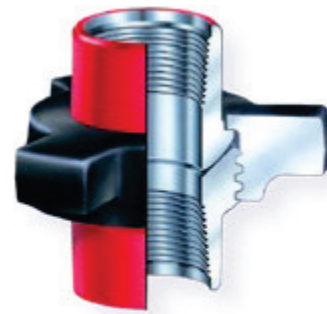

Figure 400

4,000 psi cold working pressure through 4-inch sizes; 2,500 psi cold working pressure, 5 through 12-inch sizes

Recommended service

Manifold line connections, pump suction, and mud services

Features

- ▶ 2-1/2 through 12-inch sizes have O-rings for primary seal
- ▶ Butt-weld available
- ▶ Available for sour gas service

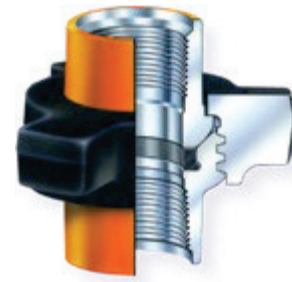

Figure 602

6,000 psi cold working pressure

Recommended service

Manifold line connections and mud service

Features

- ▶ Replaceable, lip-type seal provides primary seal, protects secondary metal-to-metal seal, and minimizes flow turbulence
- ▶ Butt-weld available
- ▶ Available for sour gas service at 6,000 psi cold working pressure

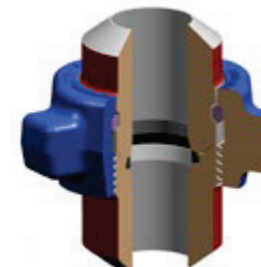

Figure 1505

15,000 psi cold working pressure

Recommended service

Fracturing,

Features

- ▶ Significant improvements in critical areas significantly extending life (available in 3-inch only)
- ▶ Thread start marker on nut eliminates cross-threading and reduces make up time
- ▶ Backward connectable with Weco® 3" 1502 iron
- ▶ Butt-weld available

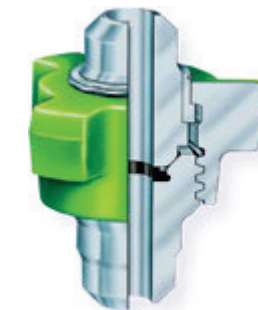

Figure 2002

20,000 psi cold working pressure

Recommended service

Cementing, fracturing, acidizing, testing, and choke-and-kill lines

Features

- ▶ Replaceable, lip-type seal
- ▶ 2 and 3-inch line sizes
- ▶ Butt-weld configurations only

▶ **To enhance safety,** 2" Figure 602 and 1002 female subs have been modified so they cannot engage the 2" Figure 1502 nut. A Go No-Go identification ring is available to determine whether the female sub is a 2" Figure 602, 1002 or a 2" Figure 1502.

▶ See specifications tables (pgs. 52-55) for sizes, dimensions, weights, materials, and part numbers.

Wecco® wing union specifications

Figure 100 - 1,000 psi (69 bar) cold working pressure

Nominal pipe size	in.	2	2½	3	4	6	8
Union part No. Qty/carton		3200609 16	3200610 10	3200611 6	3200612 4	3200795 1	3200796 1
A Clearance radius	in. mm	3% 81	3% 100	4% 114	5% 135	6% 176	8% 209
B Outside diameter	in. mm	2% 69.8	3% 83	4% 102	5% 132	7% 186	9% 241
C End-to-end threaded	in. mm	3% 92	4% 109	4% 124	5% 146	6% 171	7% 183
D Inside diameter	in. mm	2% 54.7	2% 65	3% 81	4% 106	6% 160	8% 209
Weight	lb kg	6 2.7	10 4.5	14 6.4	22 10	45 20.4	66 30
Material, sub Material, nut		DI DI	DI DI	DI DI	DI DI	DI DI	DI DI

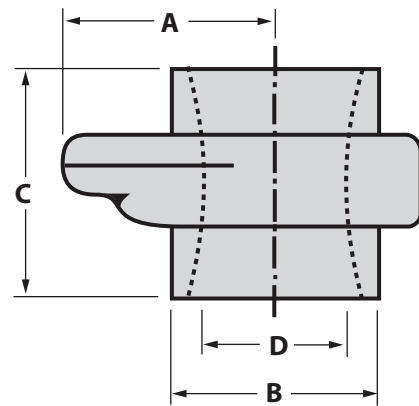

Figure 200 - 2,000 psi (138 bar) cold working pressure

Nominal pipe size	in.	1	1¼	1½	2	2½	3	4
Union part No. Qty/carton		3200829 40	3200960 28	3200773 28	3200778 16	3200899 10	3200782 6	3200912 4
A Clearance radius	in. mm	1% 50	2% 57	2% 64	3% 76	3% 90	4% 102	4% 119
B Outside diameter	in. mm	1% 40	2% 51	2% 57	2% 74	3% 84	4% 104	5% 130
C End-to-end threaded	in. mm	2% 66	2% 71	2% 71	3% 90	4% 105	4% 115	4% 125
D Inside diameter	in. mm	1% 28	1% 37	1% 43	2% 55	2% 65	3% 81	4% 106
Weight	lb kg	2 0.9	2 0.9	3 1.4	5 2.3	9 4.1	13 5.9	18 8.2
Material, sub Material, nut		CS DI	CS DI	CS DI	DI DI	CS DI	SF SF	SF SF

Note:

- **Materials**
- **AS** - alloy steel
- **CS** - carbon steel
- **DI** - ductile iron casting
- **SC** - steel casing
- **SF** - steel forging

Figure 206 - 2,000 psi (138 bar) cold working pressure

Nominal pipe size	in.	1	1¼	1½	2	2½	3	4	6	8	10
Union part No. Qty/carton		3207627 40	3207633 28	3207636 28	3207281 16	3207278 10	3203048 6	3205449 4	3202521 1	3202552 1	3202566 1
A Clearance radius	in. mm	2% 51	2% 57	2% 64	3% 76	3% 90	4% 102	4% 119	6% 159	7% 189	9% 229
B Outside diameter	in. mm	1% 40	1% 50	2% 57	2% 71	3% 85	4% 104	5% 130	7% 191	9% 243	11% 292
C End-to-end threaded	in. mm	2% 67	2% 71	2% 71	3% 83	4% 105	4% 115	5% 127	6% 169	7% 183	9% 231
D Inside diameter	in. mm	1% 28	1% 37	1% 43	2% 55	2% 65	3% 81	4% 106	6% 160	8% 209	10% 262
Weight	lb kg	2 0.9	2 0.9	3 1.4	5 2.3	8 3.6	13 5.9	18 8.2	42 19.1	65 29.5	90 40.8
Material, sub Material, nut		CS DI	CS DI	CS DI	SF DI	CS DI	SF SF	SF SF	SF SF	SF SC	SF SC

Wecco® wing union specifications

Figure 207 - 2,000 psi (138 bar) cold working pressure

Nominal pipe size	in.	3	4	6	8	10
Union part No. Qty/carton		3207906 8	3207907 4	3207908 1	3207981 1	3207982 1
A Clearance radius	in. mm	5% 146	7% 135	9% 252	12% 314	14% 368
B Outside diameter	in. mm	4% 104	5% 130	7% 191	9% 243	11% 292
C End-to-end threaded	in. mm	3% 95	4% 109	5% 148	8% 219	9% 246
D Inside diameter	in. mm	3% 81	4% 106	6% 160	8% 209	10% 262
Weight	lb kg	10 4.5	16 7.3	37 16.8	70 31.9	96 43.5
Material, sub Material, nut		SF SC	SF SF	SF SC	SF SC	SF SC

Figure 400 - 4,000 psi (276 bar) to 4"; 2,500 psi (172 bar) cold working pressure, 5" to 12"

Nominal pipe size	in.	2	2½	3	4	5½ OD*	6	7 OD*	8	12
Union part No. Qty/carton		3200291 6	3200290 5	3200292 4	3200337 3	3206347 1	3202179 1	3204333 1	3202060 1	3201578 1
A Clearance radius	in. mm	3% 89	4% 103	4% 111	5% 127	5% 148	6% 171	6% 171	7% 198	10% 272
B Outside diameter	in. mm	3% 78	3% 89	4% 106	5% 133	6% 159	7% 197	7% 171	9% 244	14 356
C End-to-end threaded	in. mm	5% 133	6% 154	6% 158	8% 209	10% 266	11% 281	11% 281	11% 291	10% 278
D Inside diameter	in. mm	2% 55	2% 65	3% 81	4% 106	5% 130	6% 160	6% 169	8% 209	12% 313
Weight	lb kg	11 5	16 7.3	19 8.6	28 12.7	47 21.3	64 29	61 27.7	95 43.1	163 73.9
Material, sub Material, nut		SF SF	CS SF	SF SF	SF SF	SF SC	CS SC	CS SC	SF SC	SC SC

Figure 602 - 6,000 psi (414 bar) cold working pressure

Nominal pipe size	in.	1	1¼	1½	2	3	4
Union part No. Qty/carton		3202377 32	3202434 9	3202428 9	P533564 6	3202416 4	3202399 2
A Clearance radius	in. mm	2% 60	3% 83	3% 83	3% 92	4% 114	5% 132
B Outside diameter	in. mm	1% 44	2% 65	2% 65	3% 78	4% 106	5% 133
C End-to-end threaded	in. mm	3% 90	4% 124	4% 124	5% 146	6% 159	8% 210
D Inside diameter	in. mm	1% 28	1% 36	1% 43	2% 52	3% 81	4% 106
Weight	lb kg	3 1.4	10 4.5	9 4.1	15 6.8	21 9.5	31 14
Material, sub Material, nut		CS SF	CS SF	CS SF	SF SF	SF SF	SF SF

Note:

- * Casing thread standard
- 2 inch does have O-ring
- **Materials**
- **AS** - alloy steel
- **CS** - carbon steel
- **DI** - ductile iron casting
- **SC** - steel casing
- **SF** - steel forging

Weco® wing union specifications

Figure 1003 - 10,000 psi (690 bar) 2"-3"; 7,500 psi (517 bar) cold working pressure 4"-5" *

Nominal pipe size	in.	2	3	4
Union part No.		3208519	3219928	3219932
Qty/carton		6	2	1
A Clearance radius	in.	3 $\frac{3}{8}$	4 $\frac{1}{2}$	5 $\frac{1}{2}$
	mm	95	124	146
B Outside diameter	in.	3	4 $\frac{1}{2}$	5 $\frac{1}{2}$
	mm	76	111	140
C End-to-end threaded	in.	4 $\frac{1}{2}$	9 $\frac{1}{2}$	10 $\frac{9}{16}$
	mm	118	232	278
D Inside diameter	in.	2 $\frac{1}{2}$	3 $\frac{3}{8}$	4
	mm	55	81	102
Weight	lb	12	45	74
	kg	5.4	20.4	33.6
Material, sub		AS	AS	AS
Material, nut		SF	SC	SF

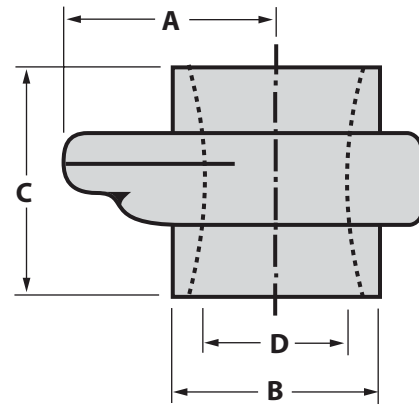

Figure 1002 - 10,000 psi (690 bar) to 4"; 7,500 psi (517 bar) cold working pressure, 5"-6" *

Nominal pipe size	in.	1	1 $\frac{1}{4}$	1 $\frac{1}{2}$	2	2 $\frac{1}{2}$	2 $\frac{1}{2}$ (EUE)	3	4
Union part No.		3205681	3205675	3205665	P535063	3205626	3206927	3205565	3205533
Qty/carton		32	10	10	6	5	5	4	2
A Clearance radius	in.	2 $\frac{1}{2}$	3 $\frac{1}{2}$	3 $\frac{1}{2}$	3 $\frac{3}{8}$	3 $\frac{3}{8}$	4	4 $\frac{1}{2}$	4 $\frac{1}{2}$
	mm	56	77	77	97	99	102	115	126
B Outside diameter	in.	1 $\frac{1}{4}$	2 $\frac{1}{8}$	2 $\frac{1}{8}$	3 $\frac{1}{2}$	3 $\frac{1}{2}$	3 $\frac{3}{8}$	4 $\frac{1}{4}$	5 $\frac{1}{8}$
	mm	44	65	65	78	89	94	108	135
C End-to-end threaded	in.	3 $\frac{7}{8}$	4 $\frac{1}{2}$	4 $\frac{1}{2}$	5 $\frac{1}{2}$	6 $\frac{1}{8}$	5 $\frac{1}{8}$	6 $\frac{1}{2}$	8 $\frac{1}{2}$
	mm	90	124	124	146	156	151	158	209
D Inside diameter	in.	1 $\frac{1}{4}$	1 $\frac{1}{2}$	1 $\frac{1}{8}$	2 $\frac{1}{8}$	2 $\frac{1}{8}$	2 $\frac{3}{8}$	3 $\frac{1}{8}$	4 $\frac{1}{8}$
	mm	28	36	43	52	65	71	81	106
Weight	lb	4	10	9	16	18	16	22	32
	kg	1.8	4.5	4.1	7.3	8.2	7.3	10	14.5
Material, sub		AS	AS	AS	SF	AS	AS	AS	AS
Material, nut		SF	SF	SF	SF	SC	SF	SF	SF

Note:

* 5" - 6" available with butt weld ends; consult factory for other configurations.

Figure 1502 - 15,000 psi (1034 bar) cold working pressure

Nominal pipe size	in.	1	1 $\frac{1}{2}$	2	2 $\frac{1}{2}$	3	4*
Union part No.		3254059	3254057	3201570	3203088	3207510	3252926
Qty/carton		19	10	5	4	3	1
A Clearance radius	in.	2 $\frac{1}{2}$	3 $\frac{3}{8}$	3 $\frac{3}{8}$	4 $\frac{1}{2}$	4 $\frac{1}{2}$	6
	mm	73	93	99	106	114	300
B Outside diameter	in.	2 $\frac{1}{2}$	2 $\frac{3}{8}$	3 $\frac{1}{8}$	3 $\frac{3}{8}$	4 $\frac{1}{2}$	5 $\frac{1}{4}$
	mm	55	75	81	95	112	146
C End-to-end threaded	in.	4 $\frac{1}{2}$	5 $\frac{1}{2}$	7	7 $\frac{1}{4}$	7 $\frac{1}{4}$	8 $\frac{1}{2}$ *
	mm	110	137	178	184	194	216
D Inside diameter	in.	1 $\frac{1}{8}$	1 $\frac{1}{8}$	2 $\frac{1}{8}$	2 $\frac{1}{8}$	3 $\frac{1}{8}$	-
	mm	28	43	52	65	81	-
Weight	lb	9	17	19	22	30	64
	kg	4.1	7.7	8.6	10	13.6	29
Material, sub		AS	AS	SF	AS	AS	AS
Material, nut		SF	SF	SF	SC	SF	SF

Note:

* Non-pressure seal

Weco® wing union specifications

Figure 1505 - 15,000 psi (1034 bar) cold working pressure

Nominal pipe size	in.	1	1 $\frac{1}{2}$	2	2 $\frac{1}{2}$	3	4*
Union part No.		3254059	3254057	3201570	3203088	3207510	3252926
Qty/carton		19	10	5	4	3	1
A Clearance radius	in.	2 $\frac{1}{2}$	3 $\frac{3}{8}$	3 $\frac{3}{8}$	4 $\frac{1}{2}$	4 $\frac{1}{2}$	6
	mm	73	93	99	106	114	300
B Outside diameter	in.	2 $\frac{1}{2}$	2 $\frac{3}{8}$	3 $\frac{1}{8}$	3 $\frac{3}{8}$	4 $\frac{1}{2}$	5 $\frac{1}{4}$
	mm	55	75	81	95	112	146
C End-to-end threaded	in.	4 $\frac{1}{2}$	5 $\frac{1}{2}$	7	7 $\frac{1}{4}$	7 $\frac{1}{4}$	8 $\frac{1}{2}$ *
	mm	110	137	178	184	194	216
D Inside diameter	in.	1 $\frac{1}{8}$	1 $\frac{1}{8}$	2 $\frac{1}{8}$	2 $\frac{1}{8}$	3 $\frac{1}{8}$	-
	mm	28	43	52	65	81	-
Weight	lb	9	17	19	22	30	64
	kg	4.1	7.7	8.6	10	13.6	29
Material, sub		AS	AS	SF	AS	AS	AS
Material, nut		SF	SF	SF	SC	SF	SF

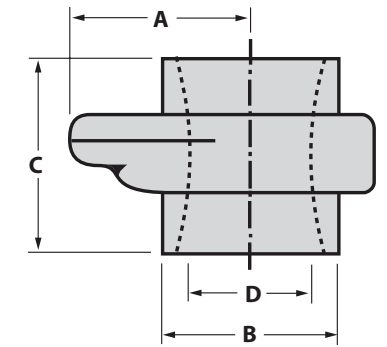

Note:

* Non-pressure seal

Figure 2002 - 20,000 psi (1380 bar) cold working pressure

Nominal pipe size	in.	2	3
Union part No.		3222761	3245911
Qty/carton		5	1
A Clearance radius	in.	3 $\frac{3}{8}$	6 $\frac{1}{2}$
	mm	95	155
B Outside diameter	in.	2 $\frac{1}{2}$	5 $\frac{1}{2}$
	mm	66	140
C End-to-end threaded	in.	7 $\frac{1}{2}$	10 $\frac{1}{2}$
	mm	188	267
D Inside diameter	in.	1 $\frac{1}{8}$	3
	mm	33	76
Weight	lb	21	87
	kg	9.5	39.5
Material		AS	AS

Figure 2202 - 15,000 psi (1034 bar) cold working pressure

Nominal pipe size	in.	2	3
Union part No.		3235746	3257994
Qty/carton		5	1
A Clearance radius	in.	3 $\frac{3}{8}$	6 $\frac{1}{2}$
	mm	95	155
B Outside diameter	in.	2 $\frac{1}{2}$	5 $\frac{1}{2}$
	mm	73	140
C End-to-end threaded	in.	8 $\frac{9}{16}$	10 $\frac{1}{2}$
	mm	224	267
D Inside diameter	in.	1 $\frac{1}{8}$	3
	mm	33	76
Weight	lb	22	53
	kg	10	24
Material		AS	AS

Sour gas service

TechnipFMC manufactures Weco® sour gas wing unions in accordance with the National Association of Corrosion Engineers (NACE) Standard MR-01-75 and American Petroleum Institute (API) Standard RP-14-E. These outstanding, field-proven unions are specially heat treated for controlled hardness. For fast, sure identification, each Weco® sour gas union is stamped “Sour Gas” or “NACE MR-01-75” using low stress dot stamping and painted with an olive green zinc-chromate primer that is unique to sour gas equipment. TechnipFMC flowline products use fluoroelastomer seals or O-rings in all sour gas unions, but do not warrant the performance of any elastomer for sour gas service. **(See Warnings).**

1. Quick, positive identification

Weco® unions for sour gas service are stamped “Sour Gas” and painted with an olive green zinc-chromate primer to ensure quick, positive identification.

2. Meets industry standards

All Weco® wing unions for sour gas service meet both the NACE Standard MR-01-75 and API Standard RP-14-E.

3. Controlled hardness

Weco® union subs and nuts are specially heat-treated and 100% tested for controlled hardness.

4. Positive sealing

Primary fluoroelastomer seal and metal-to-metal seal combine to deliver positive sealing throughout the stated pressure range.

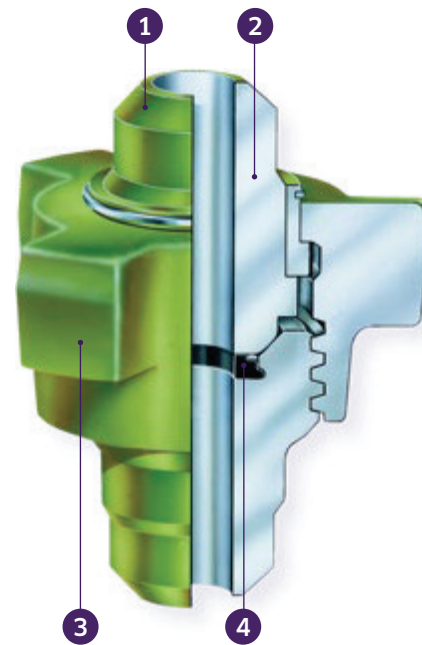

Weco® wing unions for sour gas service

Figure 400

4,000 psi cold working pressure, 1 through 4-inch sizes; 2,500 psi cold working pressure, 5 through 12-inch; butt-weld only above 4-inch sizes

Figure 602

6,000 psi cold working pressure, 1 through 4-inch sizes

Figure 1003

7,500 psi cold working pressure, 2 and 3-inch sizes; 5,000 psi cold working pressure, 4 and 5-inch sizes

Figure 1502

10,000 psi cold working pressure, 1 through 4-inch sizes; butt-weld or non-pressure seal configurations only

Figure 2202

15,000 psi cold working pressure, 2, and 3-inch sizes; butt-weld only

➤ See specifications tables (pgs .52-55) for sizes, dimensions, weights, materials, and part numbers.

Other Weco® unions

Suction-hose unions

500 psi maximum line pressure, 4, 5, and 6-inch sizes

Recommended service

Mud system suction lines

Features

- ▶ Replaceable O-ring seal
- ▶ Choice of end fittings
- ▶ Secondary metal-to-metal seal
- ▶ Socket welded, threaded, or hose nipple

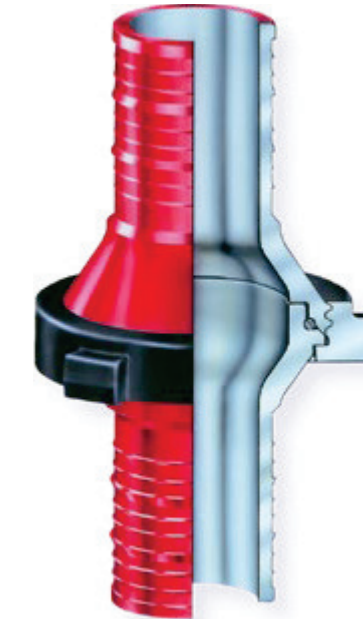
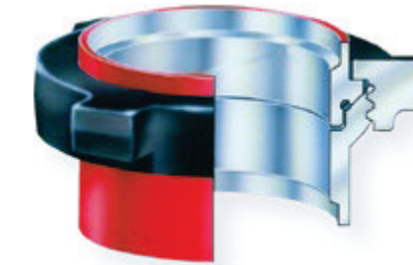

Caution:

It is possible to interchange sour gas parts with standard service products. Users must adopt safe practices for identification, installation, use, maintenance, and storage of sour gas equipment. **(See warnings and cautions, page 88).**

Suction-hose unions - 500 psi (34 bar) maximum line pressure

Size/type	Part No.	Qty./carton	Length		Nut radius		Materials		Weight	
			in.	mm	in.	mm	Nut	Sub	lb	kg
6-inch hose	P512200	1	14 $\frac{1}{4}$	356	5	127	SF	CS	40	18.1
5-inch hose	3251341	1	14 $\frac{1}{4}$	356	5	127	SF	CS	31	14
5-inch socket weld	3202072	4	4 $\frac{1}{2}$	104	5	127	SF	SF	18	8.2
5-inch line pipe thread	3248972	2	7 $\frac{3}{4}$	194	5	127	SF	DI	28	13
4-inch line pipe thread	3215198	2	5 $\frac{1}{16}$	161	5	127	SF	DI	26	12
4-inch hose	3207912	2	14 $\frac{1}{2}$	368	5	127	SF	DI	25	12
Blanking cap assy.	3220990	2	3 $\frac{1}{16}$	92	5	127	SF	CS	25	12

Note: - **Materials** - **AS** - alloy steel, **CS** - carbon steel, **DI** - ductile iron casting, **CS** - steel casting, **SF** - steel forging

Weco® fittings and pup joints

Weco® fittings and pup joints have been optimized for minimum weight and size. These rugged products are ideal for handling a complete range of standard and sour gas well servicing fluids at pressures up to 20,000 psi.

Available in 1 to 4-inch sizes, both fittings and pups feature forged construction with integral Weco® wing union ends for a high-strength, high-integrity connection every time. Weco® pups and fittings come with full material traceability and can be supplied with Charpy impact values. Like all pressure containing products, Weco® pups and fittings require special handling (See Warnings).

Weco® fittings

Up to 20,000 psi cold working pressure; 1 to 4-inch bore sizes

Recommended service

High-pressure well servicing lines, fracturing lines, testing lines, cementing and circulating lines, and other well service and stimulation applications

1. Forged construction with full traceability

2. Optimized, lightweight designs

Save valuable weight and space.

3. Complete range of configurations

Tees, elbows, crosses, wyes, and laterals can be combined to suit virtually any application.

4. Integral Weco® wing union end connections

High-strength, high integrity connections every time.



Weco® pup joints

Up to 20,000 psi cold working pressure; 1, 1½, 2, 3, and 4-inch bore sizes, lengths to 20 feet

Recommended service

High-pressure well servicing lines, fracturing lines, testing lines, cementing and circulating lines, and other well service and stimulation applications.

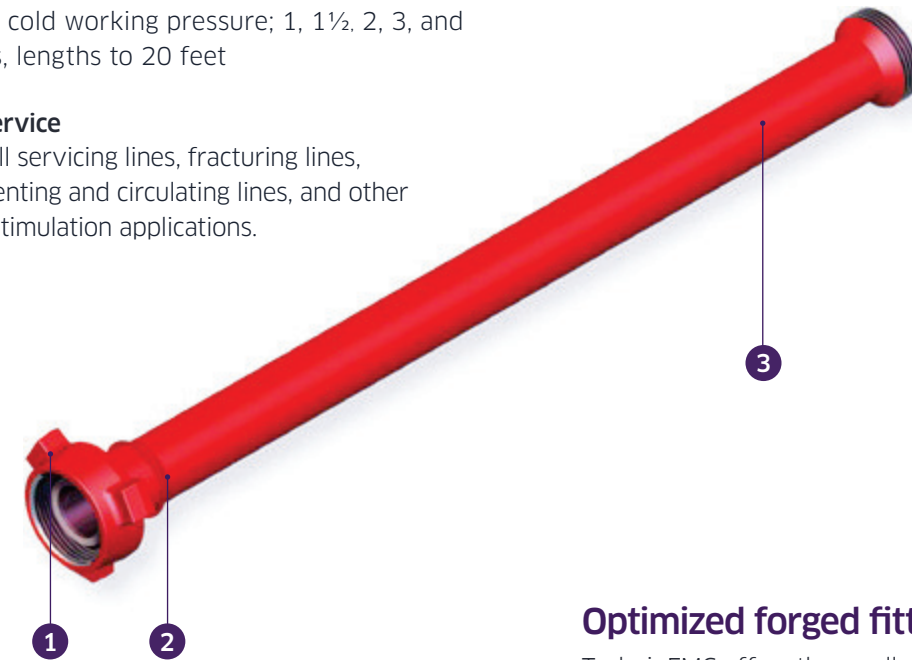

1. Weco® wing union nut detaches for field repair

Permits fast, easy service at the job site.

- ▶ Standard on Integral design.
- ▶ Optional on NPST design.

2. Patented retention shoulder prevents nut from sliding down pup

- ▶ Design decreases risk of injury to personnel.
- ▶ Standard on Integral design. Optional on NPST design.
- ▶ Optional on NPST design.

3. Integral and NPST designs

Available in integral and non-pressure seal designs to suit virtually all oilfield applications.

Optimized forged fittings

TechnipFMC offers the smallest, lightest integral forged fittings on the market. To minimize the size and weight of each fitting, engineers performed a finite element stress analysis on each fitting body design. From these results, the geometry was optimized for weight, and forgings were developed for each size and type of fitting. The fittings were then subjected to laboratory and field testing. The result: You save weight and space without sacrificing service life or safety.

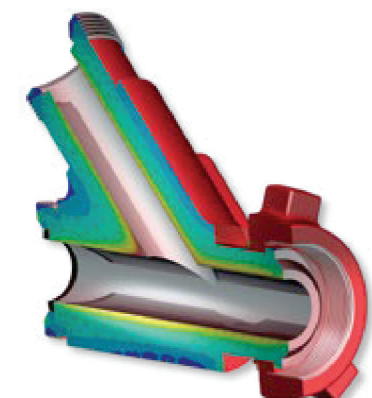

Weco® integral fittings specifications

Dimensional data

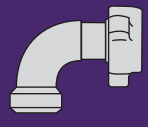
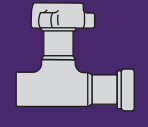
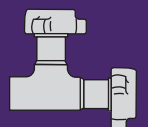
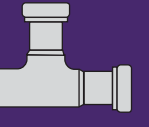
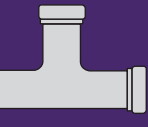
Nom. size in.	Weco wing union	CWP psi bar	Longsweep elbow		Elbows							
												
			P/N P/N-LT	lb kg	P/N P/N-LT	lb kg	P/N P/N-LT	lb kg	P/N P/N-LT	lb kg	P/N P/N-LT	lb kg
1	1502	15,000 1034	–	–	P506048 P506048-LT	27 (12.4)	P506053 P506053-LT	CF*	P506061 P506061-LT	CF*	P506069 P506069-LT	29 13.2
			–	–	P506049 P506049-LT	CF*	P506054 P506054-LT	CF*	P506062 P506062-LT	CF*	–	–
2	602	6,000 414	3262554	24 11	P506050 P506050-LT	30 14	–	–	P506063 P506063-LT	18 8.2	P506071 P506071-LT	26.6 12
	1502	15,000 1034	3260403	27 12.6	P503846 P503846-LT	32 14.7	P506056 P506056-LT	41 18.5	P506064 P506064-LT	24 10.9	P503842 P503842-LT	29 13.2
	2002	20,000 1380	CF*	CF*	P506051 P506051-LT	36 16.3	P506057 P506057-LT	CF*	P506065 P506065-LT	CF*	–	–
3	602	6,000 414	3259683 3259683-LT	54 24.5	3267335 3267335-LT	101 45.6	–	–	–	–	–	–
	1502	15,000 1034	3259845 3259845-LT	50 23	3265950 3265950-LT	102 46.3	P506059 P506059-LT	121 54.9	P506067 P506067-LT	87 39.5	3268575 3268575-LT	114 51.7
	1505	15,000 1034	–	–	CF*	CF*	CF*	CF*	CF*	CF*	CF*	CF*
	2002	20,000 1380	–	–	P519448 P519448-LT	221 100	CF*	CF*	CF*	CF*	P524672 P524672-LT	220 99.8
4	602	6,000 414	P506172 P506172-LT	76 35	P506052 P506052-LT	CF*	P506060 P506060-LT	CF*	P506068 P506068-LT	CF*	–	–
	1002	10,000 690	3261102 3261102-LT	77 35	3268033 3268033-LT	101 45.8	3268115 3268115-LT	105 47.6	3268113 3268113-LT	75 34	P500631 P500631-LT	101 45.8
	1502	15,000 1034	–	–	CF*	CF*	CF*	CF*	CF*	CF*	–	–

*Consult factory

Dimensional data

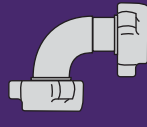
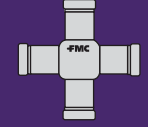
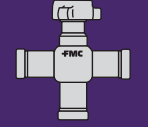
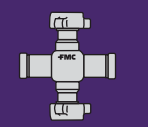
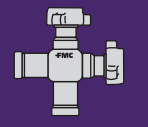
Nom. size in.	Weco wing union	CWP psi bar	Longsweep elbow		Crosses							
												
			P/N P/N-LT	lb kg	P/N P/N-LT	lb kg	P/N P/N-LT	lb kg	P/N P/N-LT	lb kg	P/N P/N-LT	lb kg
1	1502	15,000 1034	–	–	P506107 P506107-LT	CF*	P506113 P506113-LT	CF*	P506118 P506118-LT	CF*	P506129 P506129-LT	CF*
1.5	1502	15,000 1034	–	–	P503531 P503531-LT	65 30	3269120 3269120-LT	77 33	–	–	P506130 P506130-LT	83 37.6
	602	6,000 414	–	–	–	–	–	–	3262655 3262655-LT	52 24	P506131 P506131-LT	67 30.4
2	1502	15,000 1034	3261768 3261768-LT	34 15.4	3257972 3257972-LT	59 26.8	3257973 3257973-LT	69 32	3258450 3258450-LT	73 33.1	3258451 3258451-LT	76 35
	2002	20,000 1380	CF*	CF*	3267282 3267282-LT	80 36.3	P506115 P506115-LT	69 32	P506120 P506120-LT	CF*	P506132 P506132-LT	CF*
	602	6,000 414	–	–	P506109 P506109-LT	157 71.2	P506116 P506116-LT	134 61	–	–	P506133 P506133-LT	180 81.6
3	1502	15,000 1034	P506175 P506175-LT	65 29.5	P506110 P506110-LT	136 61.7	P517401 P517401-LT	144 80.7	P506122 P506122-LT	151 68.5	P506134 P506134-LT	152 69
	1505	15,000 1034	P555280 P555280-LT	81 37	CF*	CF*	CF*	CF*	CF*	CF*	CF*	
	2002	20,000 (1380)	–	–	–	–	–	–	–	–	–	–
	602	6,000 414	P506175 P506175-LT	CF*	–	–	P504791 P504791-LT	157 71.2	–	–	–	–
4	1002	10,000 690	P506177 P506177-LT	CF*	P506112 P506112-LT	104 47	P506117 P506117-LT	157 71.2	–	–	–	–
	1502	15,000 1034	–	–	–	–	–	–	–	–	–	

*Consult factory

Weco® integral fittings specifications

Dimensional data

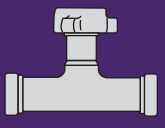
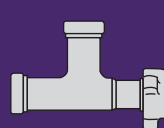
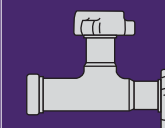
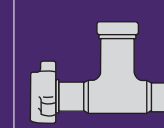
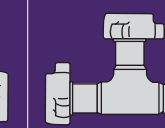
Nom. size in.	Weco wing union	CWP psi bar	Tees									
												
			P/N P/N-LT	lb kg	P/N P/N-LT	lb kg	P/N P/N-LT	lb kg	P/N P/N-LT	lb kg	P/N P/N-LT	lb kg
1	1502	15,000 1034	P506076	32	P506083	32	P506087	42	P506093	33	P506100	34
			P506076-LT	14.4	P506083-LT	14.4	P506087-LT	19	P506093-LT	15	P506100-LT	15.4
1.5	1502	15,000 1034	–	–	P505457	40	P506088	47	P506094	47	–	–
			–	–	P505457-LT	18	P506088-LT	21.1	P506094-LT	21.1	–	–
2	602	6,000 414	–	–	P506084	34	P506089	41	P506095	41	–	–
			–	–	P506084-LT	16	P506089-LT	19	P506095-LT	19	–	–
	1502	15,000 1034	P503850	38	P503840	38	P503848	46	P505362	46	P505364	54
2	2002	20,000 1380	P506090	46	P505584	42	P506080	52	–	–	–	–
			P506090-LT	21	P505584-LT	19	P506080-LT	23.6	–	–	–	–
3	602	6,000 414	–	–	P506085	124	P506091	126	–	–	–	–
			–	–	P506085-LT	56.2	P506091-LT	57.2	–	–	–	–
	1502	15,000 1034	3263821	128	3262298	128	3265538	135	3265947	135	3268629	142
	1505	15,000 1034	CF*	–	P556355	136	P556726	152	CF*	–	CF*	–
3	2002	20,000 (1380)	P524673	253	P519451	253	P524674	274	P524675	274	P524676	295
			P524673-LT	115	P519451-LT	115	P524674-LT	124	P524675-LT	125	P524676-LT	134
4	602	6,000 414	P506082	107	P506086	141	P506092	127	P506098	124	–	–
			P506082-LT	49	P506086-LT	64	P506092-LT	57.6	P506098-LT	57	–	–
	1002	10,000 690	P500633	114	3268031	110	P500632	120	–	–	P506106	140
4	1502	15,000 1034	P518756	229	P518790	228	P524680	251	–	–	–	–
			P518756-LT	103.9	P518790-LT	104	P524680-LT	14	–	–	–	–

*Consult factory

Dimensional data

Nom. size in.	Weco wing union	CWP psi bar	Crosses				Laterals				Wyes	
												
			P/N P/N-LT	lb kg	P/N P/N-LT	lb kg	P/N P/N-LT	lb kg	P/N P/N-LT	lb kg	P/N P/N-LT	lb kg
1	1502	15,000 1034	P506137	CF*	P506146	CF*	P506154	58	P506160	57	P506164	CF*
1.5	1502	15,000 1034	–	–	–	–	P505434	64	–	–	P506166	30
			–	–	–	–	P505434-LT	29	–	–	P506166-LT	14
2	602	6,000 414	–	–	–	–	3263029	57	–	–	3262652	26
			–	–	–	–	3263029-LT	26	–	–	3262652-LT	12
	1502	15,000 1034	3257976	83	3257975	91	3261420	61	–	–	3208846	30
2	2002	20,000 (1380)	P506140	CF*	P506149	CF*	P506156	CF*	–	–	3254106	32
			P506140-LT	–	P506149-LT	–	P506156-LT	–	3254106-LT	14.5	–	–
3	602	6,000 414	–	–	–	–	CF*	CF*	CF*	CF*	–	–
			–	–	–	–	CF*	CF*	CF*	CF*	–	–
	1502	15,000 1034	P506142	159	P506151	166	3266805	95	P506161	82	–	–
	1505	15,000 1034	CF*	–	CF*	–	P555226	107	P506161	82	–	–
3	2002	20,000 1380	–	–	–	–	CF*	CF*	CF*	CF*	–	–
			–	–	–	–	CF*	CF*	CF*	CF*	–	–
4	602	6,000 414	–	–	–	–	P506158	168	CF*	CF*	–	–
			–	–	–	–	P506158-LT	77	CF*	CF*	–	–
	1002	10,000 690	–	–	–	–	P519459	174	CF*	CF*	–	–
4	1502	15,000 1034	–	–	–	–	P518757	288	CF*	CF*	–	–
			–	–	–	–	P518757-LT	130.6	CF*	CF*	–	–

*Consult factory

Weco® integral fittings specifications

Dimensional data

Nominal size in.	Longsweep elbow				Elbow A in. (mm)
	M x M		M x F		
	A in. (mm)	B in. (mm)	C in. (mm)	D in. (mm)	A in. (mm)
1	–	–	–	–	6.06 (154)
1.5	–	–	–	–	6.06 (154)
2	7.16 (182)	5.13 (130)	7.16 (182)	5.5 (140)	6.06 (154)
3	10 (254)	7.59 (193)	10 (254)	7.94 (202)	8 (203)
4	12.62 (321)	9.69 (246)	12.62 (321)	9.69 (246)	8.2 (208)

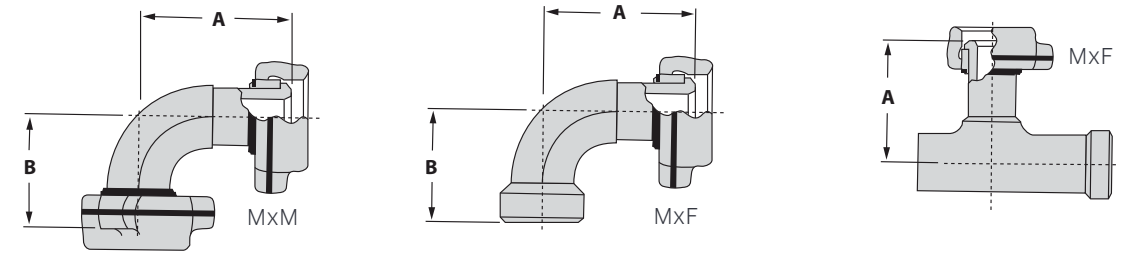

Longsweep elbows

Elbow

Dimensional data

Nominal size in.	Wyes		Tees		Cross	
	A in. (mm)	B in. (mm)	A in. (mm)	B in. (mm)	A in. (mm)	B in. (mm)
1	5.25 (133)	5 (127)	6.06 (154)	12.12 (308)	7.50 (191)	15 (381)
1.5	5.25 (133)	5 (127)	6.06 (154)	12.12 (308)	7.50 (191)	15 (381)
2	5.25 (133)	5 (127)	6.06 (154)	12.12 (308)	7.50 (191)	15 (381)
3	–	–	8 (203)	16 (406)	8 (203)	16 (406)
4	–	–	8.20 (208)	16.40 (417)	8.20 (208)	16.40 (417)

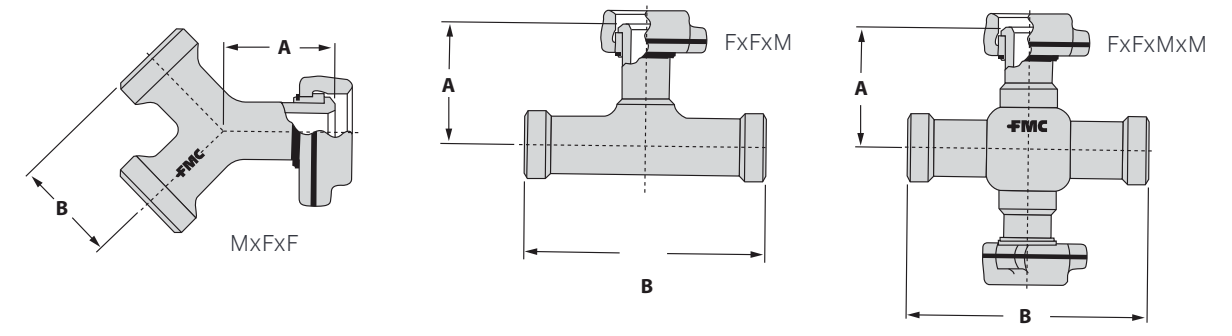

Wye

Tee

Cross

Dimensional data

Nominal size in.	Weco Wing Union End	45° Lateral			60° Lateral		
		A in. (mm)	B in. (mm)	C in. (mm)	A in. (mm)	B in. (mm)	C in. (mm)
1	–	10.50 (267)	15.75 (400)	5.25 (133)	–	–	–
1.5	–	10.50 (267)	15.75 (400)	5.25 (133)	–	–	–
2	–	10.50 (267)	15.75 (400)	5.25 (133)	–	–	–
3	602	–	–	–	8.5 (216)	16 (406)	6.63 (168)
3	1502	–	–	–	8.5 (216)	16 (406)	6.63 (168)
3	2002	15 (381)	20.26 (515)	7.63 (194)	–	–	–
4	602	–	–	–	11.50 (292)	19.50 (495)	8 (203)
4	1002	–	–	–	11.50 (292)	19.50 (495)	8 (203)
4	1502	15 (381)	20.26 (515)	7.63 (194)	–	–	–

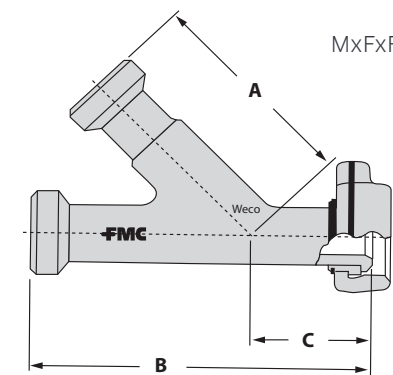

45° Lateral

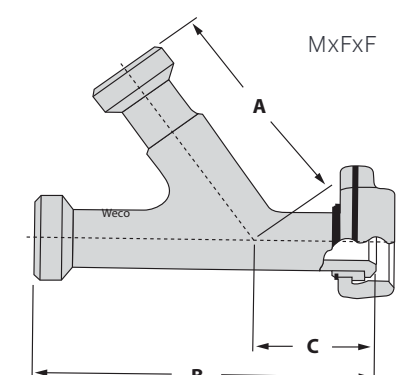

60° Lateral

Weco® pup joints

NPS non-detachable nut

Sizes	Weco union end	CWP psi bar	2 ft (610 mm)		3 ft (914 mm)		4 ft (1,219 mm)		5 ft (1,524 mm)		6 ft (1,829 mm)	
			P/N P/N-LT	lb kg	P/N P/N-LT	lb kg	P/N P/N-LT	lb kg	P/N P/N-LT	lb kg	P/N P/N-LT	lb kg
1"	1502	15,000 1034	P515014	15	3265578	18	3265579	21	3265580	24	3262631	27
			P515014-LT	6.8	3265578-LT	8.2	3265579-LT	9.5	3265580-LT	10.9	3262631-LT	12.2
1.5"	1502	15,000 1034	3256224	29	3265598	35	3254968	42	3265599	48	3265600	93
			3256224-LT	13.2	3265598-LT	15.9	3254968-LT	19.1	3265599-LT	21.8	3265600-LT	43
2"	602	6,000 414	CF*	–	P528321	34	CF*	–	P528320	48	3265733	55
					P528321-LT	15			P528320-LT	22	3265733-LT	25
2"	1502	15,000 1034	3255329	31	3255328	38	3255522	45	3255327	52	3255524	59
			3255329-LT	14.1	3255328-LT	17.2	3255522-LT	20.4	3255327-LT	23.6	3255524-LT	26.8
3"	602	6,000 414	3268620	49	3267340	63	3267722	78	3267339	92	P501345	106
			3268620-LT	22.2	3267340-LT	28.6	3267722-LT	35.4	3267339-LT	41.7		48.1
3"	1502	15,000 1034	3255323	55	3255322	69	3255380	84	3255321	98	3255379	112
			3255323-LT	24.9	3255322-LT	31.3	3255380-LT	38	3255321-LT	44.5	3255379-LT	50.8
4"	602	6,000 414	P507216	70	CF*	–	3251806	95	6101173	136	3251807	157
			P507216-LT	32			3251806-LT	43.1	6101173-LT	62	3251807-LT	71.2
4"	1502	10,000 690	3265769	71	P506629	94	3265771	114	3265772	133	3265773	157
			3265769-LT	32	P506629-LT	43	3265771-LT	52	3265772-LT	60.3	3265773-LT	72

*Consult factory

8 ft (2,438 mm)		10 ft (3,048 mm)		12 ft (3,658 mm)		20 ft (6,096 mm)	
P/N P/N-LT	lb kg	P/N P/N-LT	lb kg	P/N P/N-LT	lb kg	P/N P/N-LT	lb kg
3256612	35	3265583	39	P504985	45	CF*	45
3256612-LT	16	3265583-LT	18	P504985-LT	20.4		20.4
3254969	68	3256062	81	CF*	–	CF*	–
3254969-LT	30.8	3256062-LT	36.7				
CF*	–	P528319	82	3265739	96	CF*	80
		P528319-LT	38		44		36.3
3255326	73	3255325	86	3255324	100	3265728	155
3255326-LT	33.1	3255325-LT	39	3255324-LT	45.4	3265728-LT	70.3
P504506	135	3267338	163	P501344	192	CF*	192
P504506-LT	61.2	3267338-LT	73.9	P501344-LT	87.1		87.1
3255320	141	3255423	169	3255381	198	3255427	313
3255320-LT	64	3255423-LT	76.7	3255381-LT	89.8	3255427-LT	142
P514350	200	3251808	240	CF*	–	CF*	–
P514350-LT	90.7	3251808-LT	109				
3265775	198	3265777	240	CF*	–	CF*	–
3265775-LT	89.8	3265777-LT	109				

*Consult factory

NPS detachable nut (20 ft (6,096 mm) size: consult factory)

Sizes	Weco union end	CWP psi bar	2 ft 610 mm)		3 ft 914 mm)		4 ft 1,219 mm)		5 ft 1,524 mm)	
			P/N P/N-LT	lb kg	P/N P/N-LT	lb kg	P/N P/N-LT	lb kg	P/N P/N-LT	lb kg
2"	1502	15,000 1034	3265907	31	P513374	38	3265908	45	3265909	52
				14.1	P513374-LT	17.2	3265908-LT	20.4	3265909-LT	23.6
3"	1502	15,000 1034	3267024	38	CF*	–	3267025	84	3267026	99
			3267024-LT	18			3267025-LT	38.1	3267026-LT	44.9
4"	602	6,000 414	CF*	–	CF*	–	CF*	–	P514712	136
									P514712-LT	61.7

*Consult factory

6 ft 1,829 mm)		8 ft 2,438 mm)		10 ft 3,048 mm)		12 ft 3,658 mm)	
P/N P/N-LT	lb kg	P/N P/N-LT	lb kg	P/N P/N-LT	lb kg	P/N P/N-LT	lb kg
P511842	59	P512102	73	3265906	86	CF*	CF*
P511842-LT	26.8	P512102-LT	33.1	3265906-LT	39		
P513301	113	CF*	–	3267053	170	CF*	–
P513301-LT	51.3			3267053-LT	77.1		
P514711	158	P514713	200	P514715	244	3265739	96
P514711-LT	71.7	P514713-LT	90.7	P514715-LT	111	3265739-LT	44

*Consult factory

Weco® pup joints

NPS detachable nut with retention shoulder

Sizes	Weco union end	CWP psi bar	2 ft (610 mm)		3 ft (914 mm)		4 ft (1,219 mm)		5 ft (1,524 mm)		6 ft (1,829 mm)	
			P/N P/N-LT	lb kg	P/N P/N-LT	lb kg	P/N P/N-LT	lb kg	P/N P/N-LT	lb kg	P/N P/N-LT	lb kg
2"	1502	15,000 1034	P508589	32	P508590	39	P508591	46	P508592	53	P508593	60
				14.5		17.7		20.9		24		27.2
3"	1502	15,000 1034	P508600	56	P508601	70	P508602	84	P508603	99	P508604	113
				25.4		31.8		38.1		44		51.3
4"	602	6,000 414	CF*	–	CF*	–	P510406	121	P510407	118	P510408	164
				–		54.9		53.5		174.4		
4"	1002	10,000 690	P512866	76	P512867	98	P510400	119	P510401	140	P510402	161
				35		45		54		64		74
4"	1502	15,000 1034	P520514	125	P520515	155	P520520	185	P520521	215	P520522	245
				57		70		84		98		111

*Consult factory

8 ft (2,438 mm)		10 ft (3,048 mm)		12 ft (3,658 mm)		20 ft (6,096 mm)	
P/N P/N-LT	lb kg	P/N P/N-LT	lb kg	P/N P/N-LT	lb kg	P/N P/N-LT	lb kg
P508594	71 32	P508595 P508595-LT	87 39.5	P508596	101 45.8	P508598	156 70.8
P508605	142 64.4	P508606	170 77.1	P508607	199 90.3	P508609	313 142
P510409	207 93.9	P510410	249 112	P510411	292 132.4	P512873	463 210
P510403	204 93	P510404	247 113	P510405	293 133	P512105	460 209
P531126	305 138	P513472	365 166	CF*	–	P520526	665 302

*Consult factory

Integral

In"	Weco union end	CWP psi bar	2 ft (610 mm)		3 ft (914 mm)		4 ft (1,219 mm)	
			P/N P/N-LT	lb kg	P/N P/N-LT	lb kg	P/N P/N-LT	lb kg
1"	1502	15,000 1034	3263200	24	P512501	25	3262915	31
				10.9		11.3		14.1

5 ft (1,524 mm)		6 ft (1,829 mm)		8 ft (2,438 mm)		10 ft (3,048 mm)	
P/N P/N-LT	lb kg	P/N P/N-LT	lb kg	P/N P/N-LT	lb kg	P/N P/N-LT	lb kg
3261090	37 16.8	3262229	64 29	3266745	55 25	3261496	67 30.4

Integral with retention shoulder

In"	Weco union end	CWP psi bar	3 ft (914 mm)		4 ft (1,219 mm)		5 ft (1,524 mm)	
			P/N P/N-LT	lb kg	P/N P/N-LT	lb kg	P/N P/N-LT	lb kg
2"	1502	15,000 1034	P516825	41	P516823 P516823-LT	50	P516821 P516821-LT	58
				18.6		22.7		26.3
3"	1502	15,000 1034	P517538	73	P517582	91	P517664 P517664-LT	108
				33.1		41.3		49
3"	2002	20,000 (1380)	P525539	197	P525541	197	P525541	246
				90		90		112
3"	1505	15,000 1034	P556329	81	P555669	99	P556141	116
				37		45		53
4"	1502	15,000 1034	CF*	–	P520516	210	P518458 P518458-LT	251
				–		95		114

*Consult factory

6 ft (1,829 mm)		8 ft (2,438 mm)		10 ft (3,048 mm)		12 ft (3,658 mm)	
P/N P/N-LT	lb kg	P/N P/N-LT	lb kg	P/N P/N-LT	lb kg	P/N P/N-LT	lb kg
P516820	67 30.4	P516810	84 38.1	P516485	101 45.8	P516817	118 53.5
P517672	127 58	P517674	160 72.6	P517111	195 88.5	CF*	–
P525543	295 134	–	–	P525905	542 246	P525798	642 291
P556307	133 61	P556310	168 77	P556322	202 92	–	–
–	–	P518450	371 169.2	P518437	453 206	CF*	–

*Consult factory

Temporary Pipe Restraint (TPR)



TechnipFMC's Temporary Pipe Restraint (TPR) system is used on high pressure temporary flowlines. Properly applied, this system will provide an additional level of protection for personnel and physical assets by minimizing the amount of sudden movement in the event of an iron failure. The TPR system comes in two models: Standard and Premium.

Features

- ▶ TPR System is easy to install with only R-Links and C-Links made to the same specification
- ▶ Covers can be repaired in case of damage (PM)
- ▶ Patented fiber optic inspection of core yarn damage (PM)
- ▶ Patented over-load indicator allows instant detection of prior misuse or abuse (PM)
- ▶ Warning tag contains serial number and date of manufacture
- ▶ Inner cover with red color allows quick visual inspection for outer cover damage (PM)
- ▶ R-Links can be untied at any point along the flowline for quick re-installation after repair of leaking connections
- ▶ Lighter with higher strength to weight ratio than competitive systems
- ▶ Resistant to broad range chemical attack and extreme environmental conditions

Premium

Model	Size (in)	Weight (lb/ft)	Max size @ CWP	Color	Temp range	Sizes and figure numbers
PM100	1.12	0.54	2" @ 20,000 psi; 6" @ 2,000 psi	Yellow	-75 to 250°F	2" Figure 2002 and 2202 2" (and under) Figure 1502, 1002 and 602 6" (and under) Figure 206
PM200	1.75	1.32	4" @ 10,000 psi, 3" @ 15,000 psi	Green	-75 to 250°F	3" Figure 1502, 1002 and 602 4" Figure 1002 and 602
PM300	2.12	1.93	4" @ 15,000 psi, 3" @ 20,000 psi	Blue	-75 to 250°F	3" Figure 2002 and 2202 4" Figure 1502 5" Figure 1002

Standard

Model	Size (in)	Weight (lb/ft)	Max size @ CWP	Color	Temp range	Sizes and figure numbers
S100	1.5	0.73	2" @ 20,000 psi; 4" @ 2,000 psi	Tan	-50 to 180°F	2" Figure 2002 2" (and under) Figure 1502, 1002 and 602 4" (and under) Figure 206
S200	2	1.46	3" @ 15,000 psi; 4" @ 6,000 psi; 6" @ 2,000 psi	Red	-50 to 180°F	3" Figure 1502, 1002 and 602 4" Figure 602 6" (and under) Figure 206
S300	4	2.4	4" @ 10,000 psi	Orange	-50 to 180°F	4" Figure 1002

Chemical compatibility

Chemical	Internal yarn		Cover
	Premium Synthetic	Standard Polyester	
Seawater	OK	OK	OK
Hot Water	OK	OK	OK
Saturated Steam	OK	NR	NR
Hydraulic Oil	OK	OK	OK
Kerosene	OK	OK	OK
Gasoline	OK	OK	OK
Ethylene Glycol	OK	OK	OK
Soap and Detergent Solutions (except bleach)	OK	OK	OK
Ethyl Alcohol	OK	OK	OK
Methyl Alcohol	OK	OK	OK
Hydrochloric Acid	OK	8 hours, maximum	8 hours, maximum
Hydrofluoric Acid (up to 10% solution)	OK	8 hours, maximum	8 hours, maximum
Sodium Hydroxide (up to 10% solution)	OK	OK	OK
Acetone	OK	OK	OK
Benzene	OK	OK	OK
Ethers	OK	OK	OK
Toluene	OK	OK	NR
Xylene	OK	OK	NR

Flow rates at maximum recommended velocity of 40 FPS

Size and Model	ID (IN)	FT ³ /MIN	GPM	BBL/MIN	M ³ /MIN
Swivel Joints:					
3/8" and 1/2" high pressure	0.547	4	29	0.70	0.11
3/4" and 1" low and high pressure	1.000	13	98	2.33	0.37
1-1/4" high pressure	1.375	25	185	4.41	0.70
1-1/4" and 1-1/2" low pressure and 1-1/2" high pressure	1.500	29	220	5.25	0.83
1-1/2" HP10	1.593	33	249	5.92	0.94
1-1/2" LS-15, 2" LSG-15 and LS-20	1.300	22	165	3.94	0.63
2" LS-15	1.875	46	344	8.20	1.30
2" low and high pressure	2.000	52	392	9.33	1.48
2-1/2" high pressure	2.500	82	612	14.6	2.32
3" LSG-10 and LS-15	2.750	99	741	17.6	2.80
3" high pressure	2.968	115	863	20.5	3.27
2-1/2" and 3" low pressure, 3" LS-20 LSG-15 TSi-20	3.000	118	881	21.0	3.34
3" TSi-15, 3" TSi-10, 3" TSi-6	2.750	99	741	17.6	2.80
4" HP6, FS-4	3.438	155	1,157	27.6	4.38
4" HPTL, 4" TSi-15	3.500	160	1,200	28.6	4.54
4" LS-10	3.875	197	1,470	35.0	5.57
4" TSi-10	3.750	184	1,377	32.8	5.21
4" high pressure	4.000	209	1,567	37.3	5.93
5" high pressure	5.188	352	2,636	62.8	9.98
6" low pressure	6.083	484	3,624	86.3	13.72
8" low pressure	8.000	838	6,267	149	23.72
Pup joints:					
1" 1502 integral pup joint	0.875	10	75	1.79	0.28
1.5" 1502 integral pup joint	1.300	22	165	3.94	0.63
2" 602, 1002, 1502 integral pup joint	1.750	40	300	7.14	1.14
2" 2002, 2202 integral pup joint	1.300	22	165	3.94	0.63
3" 602, 1002, 1502 integral pup joint	2.750	99	741	17.6	2.80
3" 2002, 2202 integral pup joint	3.000	118	881	21.0	3.34
4" 602, 1002 integral pup joint	3.875	197	1,470	35.0	5.57
4" 1502 integral pup joint	3.500	160	1,200	28.6	4.54
2" 602, 1002, 1502 NPST	1.750	40	300	7.14	1.14
3" 602, 1002, 1502 NPST	2.625	90	675	16.1	2.55
4" 602, 1002 NPST	3.500	160	1,200	28.6	4.54
4" 1502 NPST	3.000	118	881	21.0	3.34

Flow rates at maximum recommended velocity of 40 FPS

Size and Model	ID (IN)	FT ³ /MIN	GPM	BBL/MIN	M ³ /MIN
Plug valves:					
1" DR150, 1" ULT150	0.875	10	75	1.79	0.28
1-1/2" DR150	1.300	22	165	3.94	0.63
1" x 2" DR150, 1" x 2" ULT150	0.875	10	75	1.79	0.28
2" DR50 thru DR150	1.750	40	300	7.14	1.14
2" DR200	1.300	22	165	3.94	0.63
3" ULT150	2.750	99	741	17.6	2.80
3" ULT200	3.000	118	881	21.0	3.34
4" ULT100	3.875	197	1,470	35.0	5.57
4" ULT150	3.500	160	1,200	28.6	4.54
Swing check valves:					
1-1/2" 1502	1.300	22	165	3.94	0.63
2" 1502	1.750	40	300	7.14	1.14
2" 2002, 2202	1.300	22	165	3.94	0.63
3" 602, 1002, 1502	2.750	99	741	17.6	2.80
3" 2002, 2202	3.000	118	881	21.0	3.34
4" 1002	3.875	197	1,470	35.0	5.57
4" 1502	3.500	160	1,200	28.6	4.54

Sour gas

All TechnipFMC flowline equipment that is rated for sour gas service is acceptable for use in, or exposure to, hydrogen sulfide (H₂S) environments. Acceptable flowline is marked and identified specifically for sour gas service, with the main body components and end connections identifiable with raised or stamped lettering. All sour gas products are painted with a green color to differentiate from standard service. Additionally, all products are labeled with the pressure rating and operating temperature range.

The body components are made from alloy steel that meets the requirements of NACE MR-01-75. These materials have a maximum hardness limitation of 22 HRC and are Charpy Impacted test to -50°F (-46°C).

All equipment should be inspected at regularly scheduled intervals to ensure it meets specific criteria validating it is safe for continued use.

Weco® and Chiksan® low temperature equipment

TechnipFMC offers standard service low temperature equipment for use to -40°F (-40°C). The part numbers have a “-LT” suffix added to the standard temperature part number. These assemblies have pressure containing metallic components charpy tested to -40°F and use low temperature seals.

Typical Weco and Chiksan recommended temperature ranges

Elastomer selection	Product line and materials of construction					Temperature ranges
	Wing unions, Swivel joints		Wing unions, Swivel joints, Plug valves, Check valves, Fittings, Pup joints, Adapters		Butterfly valves	
	Ductile iron	Carbon steel	Alloy steel standard service	Alloy steel sour gas service		
No Seal (Wing Union)	X					20°F (-7°C) to 300°F (149°C)
No Seal (Wing Union)		X				0°F (-18°C) to 300°F (149°C)
Nitrile	X					20°F (-7°C) to 240°F (116°C)
Nitrile		X				0°F (-18°C) to 240°F (116°C)
Nitrile			X			-20°F (-29°C) to 240°F (116°C)
Winterized Nitrile				X		-50°F (-46°C) to 240°F (116°C)
HNBR	X					20°F (-7°C) to 300°F (149°C)
HNBR		X	X	X		10°F (-12°C) to 300°F (149°C)
Viton®	X	X	X	X		20°F (-7°C) to 300°F (149°C)
Natural Rubber Seat					X	-20°F (-29°C) to 150°F (66°C)
Nitrile Seat					X	-20°F (-29°C) to 200°F (93°C)
EPDM, Hypalon, or PTFE Seat					X	-20°F (-29°C) to 250°F (121°C)
Silicone Rubber Seat					X	-20°F (-29°C) to 300°F (149°C)
Fluoroelastomer Seat					X	-10°F (-23°C) to 300°F (149°C)
Neoprene Seat					X	0°F (-18°C) to 200°F (93°C)

TechnipFMC offers standard service low temperature equipment for use to -40°F (-40°C). The part numbers have a “-LT” suffix added to the standard temperature part number. These assemblies have pressure containing metallic components charpy tested to -40°F and use low temperature seals.

Weco® and Chiksan® low temperature ranges

PGVL - Plug valve

P/N	Description	STD/CF
P516114-LT	ULTA010 150U 1502 FXM .88B W/PLG CAP BNO	STD
P516108-LT	ULTA010 150U 2IN 1502 FXM .88B W/PLG CAP	STD
P516146-LT	ULTA010 150U 2IN 1502 FXM .38B BNO	STD
P516113-LT	ULTA010 150U 1.5IN 1502 FXM .88B W/PLG C	STD
P539257-LT	ULTA020 15K 1502 FXM 1.75B BRC012	STD
P537789-LT	ULTA020 15K 1502 FXM 1.75B BNO	STD
3265904-LT	ULTA030 15K 1502 FXM 2.75B W/PLG CAP BNO	STD
3265123-LT	ULTA030 15KU 1502 FXM 2.75B BRC032 BNO	STD
3265122-LT	ULTA030 15K 1502 FXM 2.75B DT-36 POS II	STD

P/N	Description	STD/CF
P519087-LT	ULTA030 20K 2002 FXM BRC052	CF
P537338-LT	ULTA030 20K 2002 FXM 3.00B BRC052 BNO	CF
P519453-LT	ULTA030 20K 2002 FXM DT-140	CF
P537339-LT	ULTA030 20K 2002 FXM 3.00B DT-140 36IN W	CF
3265125-LT	ULTA030 15K 1502 FXM 2.75B F/OP BNO	STD
P518352-LT	ULTA040 10K 1002 FXM 3.875B BRC052 BNO	CF
P518356-LT	ULTA040 10K 1002 FXM 3.875B DT-90 36" HW	CF
P516015-LT	ULTA040 15K 1502 FXM 3.50B BRC052 BNO	CF
P518749-LT	ULTA040 15K 1502 FXM 3.50B DT-140 BNO	CF

C&C hose

P/N	Description	STD/CF
3264538-LT	HA015 LS10 55T1 120.00 1502 000 B	CF
3254780-LT	HA015 LS10 55T1 144.00 1002 000 E	CF
3144394-LT	HA020 LS10 55T1 120.00 1502 000 B	STD
3144001-LT	HA020 LS10 55T1 144.00 1502 000 B	STD
6102805-LT	HA020 LS15 51L1 120.00 1502 000 B	STD

CV - Check valve

P/N	Description	STD/CF
P530589-LT	CVA020 TE 15K 1502 MXF BNO	CF
P537198-LT	CVA020 TE 15K 1502 MXF BNO REVERSE FLOW	CF
P537131-LT	CVA020 TE 15K 1502 MXF BNO VENT CAP	CF
P537196-LT	CVG020 TE 10K 1502 MXF DN HNO	CF
P521623-LT	CVA030 TE 15K 1502 MXF BNO	CF
P524440-LT	CVA030 TE 15K 1502 MXF BNO REVERSE FLOW	CF
P537132-LT	CVA030 TE 15K 1502 MXF BNO VENT CAP	CF
P537225-LT	CVG030 TE 10K 1502 MXF DN VIO	CF
P537202-LT	CVA030 TE 6K 0602 MXF BNO	CF
P527120-LT	CVA030 TE 6K 0602 FXM BNO REVERSE FLOW	CF
P524760-LT	CVA040 TE 15K 1502 MXF BNO	CF
P527699-LT	CVA040 TE 15K 1502MXF BNO REVERSE FLOW	CF

P/N	Description	STD/CF
P525809-LT	CVA040 TE 10K 1002 MXF BNO	CF
P527018-LT	CVA040 TE 10K 1002 MXF BNO REVERSE FLOW	CF
P527592-LT	CVA040 TE 6K 0602 MXF BNO	CF
P524738-LT	CVA010 15K 1502 MXF BNO	CF
P519734-LT	CVA015 15K 1502 FXM BNO REVERSE FLOW	CF
3269158-LT	CVA020 20K 2002 MXF 2002 BNO	CF
P520099-LT	CVA030 20K 2002 MXF DN BNO STD	CF
P536118-LT	CVA010 DART 15K 1502 MXF BNO	CF
P523811-LT	CVA015 15K DART 1502 FXM BNO DN REVERSE	CF
P525269-LT	CVA015 DART 15K 1502 MXF BNO CO2/N2	CF
P510771-LT	CVA020 DART 15K 1502 MXF BNO CO2/N2	CF
P510773-LT	CVA030 DART 15K 1502 MXF BNO CO2/N2	CF

STD = Standard Product CF= Consult Factory

Weco® and Chiksan® low temperature ranges

BFV - Butterfly valve

P/N	Description	STD/CF	P/N	Description	STD/CF
3227485-LT	BA020 0120 D*D'H BNO	CF	3225734-LT	BA050 0220 D*D'H BNO	CF
3227486-LT	BA025 0120 D*D'H BNO	CF	3225735-LT	BA060 0220 D*D'H BNO	CF
3227487-LT	BA030 0120 D*D'H BNO	CF	3225736-LT	BA080 0220 D*D'H BNO	CF
3245819-LT	BA040 0120 D*D'H BNO	CF	3225737-LT	BA100 0220 D*D'H BNO	CF
3227493-LT	BA060 0120 D*D'H BNO	CF	3225738-LT	BA120 0220 D*D'H BNO	CF
3232417-LT	BA080 0120 D*D'H BNO	CF	3225748-LT	BA020 022L D*D'H BNO	CF
3227495-LT	BA100 0120 D*D'H BNO	CF	3225749-LT	BA025 022L D*D'H BNO	CF
3227496-LT	BA120 0120 D*D'H BNO	CF	3225750-LT	BA030 022L D*D'H BNO	CF
3255865-LT	BA140 0120 D*D'H BNO	CF	3222751-LT	BA040 022L D*D'H BNO	CF
3255869-LT	BA160 0120 D*D'H BNO	CF	3225752-LT	BA050 022L D*D'H BNO	CF
3229885-LT	BA020 012N D*D'H BNO	CF	3225753-LT	BA060 022L D*D'H BNO	CF
3230052-LT	BA030 012N D*D'H BNO	CF	3225754-LT	BA080 022L D*D'H BNO	CF
3229886-LT	BA040 012N D*D'H BNO	CF	3225755-LT	BA100 022L D*D'H BNO	CF
3229887-LT	BA050 012N D*D'H BNO	CF	3225756-LT	BA120 022L D*D'H BNO	CF
3229888-LT	BA060 012N D*D'H BNO	CF	3255867-LT	BA140 022L D*D'H BNO	CF
3225730-LT	BA020 0220 D*D'H BNO	CF	3255870-LT	BA160 022L D*D'H BNO	CF
3225731-LT	BA025 0220 D*D'H BNO	CF	3255871-LT	BA180 022L D*D'H BNO	CF
3225732-LT	BA030 0220 D*D'H BNO	CF	3255872-LT	BA200 022L D*D'H BNO	CF
3225733-LT	BA040 0220 D*D'H BNO	CF	3255873-LT	BA240 022L D*D'H BNO	CF

STD = Standard Product CF= Consult Factory

Weco® and Chiksan® low temperature ranges

LS/TSI - Swivel joint

P/N	Description	STD/CF	P/N	Description	STD/CF
6101537-LT	LA010 LS10 30T 000 B LPT	STD	3141454-LT	LA010 LS10 10T 000 B FLPT X FLPT	STD
3139546-LT	LA010 LS10 50T 000 B LPT	STD	P516135-LT	LA010 LS15 80U 000 B 1502 MXF	STD
3259291-LT	LA010 LS15 30U 000 B MXF BNO	STD	3139550-LT	LA010 LS15 10U 000 B FXM BNO	STD
3139547-LT	LA010 LS15 50U 000 B FXM BNO	STD	3145886-LT	LA010 LS15 10X 000 B MXM	STD
P506047-LT	LA015 LS10 20T 000 B LPT	CF	P501542-LT	LA015 LS10 10T 000 B LPT	CF
3139779-LT	LA015 LS10 10T 000 E LPT	CF	P502504-LT	LA015 LS15 80U 000 E 1502 MXF BNO	CF
P510860-LT	LA015 LS10 20U 000 B FXM BNO	CF	3139781-LT	LA015 LS15 10U 000 E FXM BNO	CF
3139778-LT	LA015 LS15 50U 000 E MXF BNO	CF	3139780-LT	LA015 LS15 10U 000 E MXM	CF
3139888-LT	LA020 LS10 20T 000 B FLPT X FLPT	STD	3139891-LT	LA020 LS10 70T 000 B LPT	STD
3139890-LT	LA020 LS10 40T 000 B	STD	3139892-LT	LA020 LS10 80T 000 B LPT	STD
3139904-LT	LA020 LS10 50T 000 B FLPT X FLPT	STD	3139476-LT	LA020 LS10 10T 000 B FLPT X FLPT	STD
3144545-LT	LA020 LS10 60T 000 B FLPT X FLPT	STD	P505482-LT	LA020 LS15 70U 000 B FXM	STD
3144126-LT	LA020 LS15 20U 000 B MXF BNO	STD	3139901-LT	LA020 LS15 80U 000 B FXM BNO	STD
3139475-LT	LA020 LS15 50U 000 B MXF BNO	STD	3139905-LT	LA020 LS15 10U 000 B 2MX2F BNO	STD
3144630-LT	LA020 LS15 60U 000 B MXF BNO	STD	3144094-LT	LA020 LS15 100U 000 B FXM BNO	STD
3267203-LT	LA020 LS15 50U 000 B MXM	STD	P527697-LT	LA020 LS15 80U 000 B MXM	STD
6101559-LT	LA020 LS15 60U 000 B MXM HALLIBURTON	STD	3139477-LT	LA020 LS15 10U 000 B 2MX2M	STD
P509888-LT	LA020 LS15 50U 000 B FXF BNO	STD	3139903-LT	LA020 LS15 100U 000 B MXM	STD
P504952-LT	LA020 LS15 60U 000 B FXF BNO	STD	P518960-LT	LA020 LS15 10U 000 B FXF BNO BNO	STD
3144569-LT	LA020 LS20 50U 000 E MXF BNO	CF	3144570-LT	LA020 LS20 10U 000 E MXF BNO	CF
P524579-LT	LA020 LS20 20U 000 E 2002 MXM DN	CF	3144571-LT	LA020 LS20 10U 000 E MXM	CF
P512325-LT	LA020 LS20 60U 000 E 2002 MXM DN	CF	3144572-LT	LA020 LS20 100U 000 E MXM	CF
P505417-LT	TSIA030 TSI15 20U 1502 FXM BNO	STD	P524218-LT	TSIA030 TSI07 10T LPT 7.5K	STD
P505416-LT	TSIA030 TSI15 30U 1502 MXF BNO	STD	P505409-LT	TSIA030 TSI15 80U 1502 MXF BNO	STD
P505327-LT	TSIA030 TSI15 50U 1502 MXF BNO	STD	P505325-LT	TSIA030 TSI15 10U 1502 MXF BNO	STD
P505420-LT	TSIA030 TSI15 60U 1502 MXF BNO	STD	P505410-LT	TSIA030 TSI15 100U 1502 MXF BNO DN	STD
P527340-LT	TSIA030 TSI20 50U 2002 MXF BNO	CF	P505326-LT	TSIA030 TSI15 10U 1502 MXM DN	STD
P516092-LT	TSIA040 TSI10 20U 1002 MXF BNO	CF	P505411-LT	TSIA030 TSI15 100U 1502 MXM DN	STD
P517487-LT	TSIA040 TSI10 30U 1002 MXF BNO	CF	P527339-LT	TSIA030 TSI20 10U 2002 MXF BNO	CF
P516091-LT	TSIA040 TSI10 50U 1002 MXF BNO	CF	P516094-LT	TSIA040 TSI10 10U 1002 MXF BNO	CF
P530256-LT	TSIA040 TSI15 20U 1502 MXF BNO	CF	P516093-LT	TSIA040 TSI10 10U 1002 MXM DN	CF
P527331-LT	TSIA040 TSI15 50U 1502 MXF BNO	CF	P527329-LT	TSIA040 TSI15 10U 1502 MXF BNO	CF

STD = Standard Product CF= Consult Factory

Weco® and Chiksan® low temperature ranges

Fittings

P/N	Description	STD/CF
P506048-LT	YA010 1502 ELB MXF BNO 6.06	STD
P506053-LT	YA010 1502 ELB MXM 6.06	STD
P506061-LT	YA010 1502 TEE FXF BNO 6.06	STD
P506069-LT	YA010 1502 TEE FXF BNO 12.12	STD
P506049-LT	YA015 1502 ELB MXF BNO 6.06	STD
P506054-LT	YA015 1502 ELB MXM 6.06	STD
P506062-LT	YA015 1502 ELB FXF BNO 6.06	STD
P506070-LT	YA015 1502 TEE FXF BNO 12.12	STD
P506050-LT	YA020 0602 ELB MXF BNO 6.06	STD
P506055-LT	YA020 0602 ELB MXM 6.06	STD
P506063-LT	YA020 0602 ELB FXF BNO 6.06	STD
P506071-LT	YA020 0602 TEE FXF BNO 12.12	STD
P503846-LT	YA020 1502 ELB MXF BNO 6.06	STD
P506056-LT	YA020 1502 ELB MXM 6.06	STD
P506064-LT	YA020 1502 ELB FXF BNO 6.06	STD
P503842-LT	YA020 1502 TEE FXF BNO 12.12	STD
P506051-LT	YA020 2002 ELB MXF BNO 6.06 OAL	STD
P506057-LT	YA020 2002 ELB MXM 6.06 OAL	STD
P506065-LT	YA020 2002 ELB FXF BNO 6.06 OAL	STD
P506072-LT	YA020 2002 TEE FXF BNO 12.12	STD
3259683-LT	LA030 0602 00U ELB 90 MXF BNO	STD
3267335-LT	YA030 0602 ELB MXF BNO	CF
P506058-LT	YA030 0602 ELB MXM	CF
P506066-LT	YA030 0602 ELB FXF BNO	CF
P506073-LT	YA030 0602 TEE FXF BNO	CF
3259845-LT	LA030 1502 00U ELB 90 MXF BNO	STD
3265950-LT	YA030 1502 ELB MXF BNO	CF
P506059-LT	YA030 1502 ELB MXM 15K	CF
P506067-LT	YA030 1502 ELB FXF 15K	CF
3268575-LT	YA030 1502 TEE FXF BNO	CF
P519448-LT	YA030 2002 ELB FXM BNO	STD
P524672-LT	YA030 2002 TEE FXF BNO	STD
P506172-LT	LA040 0602 00U ELB 90 MXF BNO	STD
P506052-LT	YA040 0602 ELB MXF BNO	CF
P506060-LT	YA040 0602 ELB MXM	CF
P506068-LT	YA040 0602 ELB FXF BNO	CF
P506075-LT	YA040 0602 TEE FXF BNO	CF
3261102-LT	LA040 1002 00U ELB 90 MXF BNO	STD
3268033-LT	YA040 1002 ELB MXF BNO	CF
3268115-LT	YA040 1002 ELB MXM	CF
3268113-LT	YA040 1002 ELB FXF BNO	CF
P500631-LT	YA040 1002 TEE FXF BNO	CF
P524677-LT	YA040 1502 TEE FXF BNO	STD
P506076-LT	YA010 1502 TEE FFXM BNO 12.12	STD
P506083-LT	YA010 1502 TEE FXMXF BNO 12.12	STD
P506087-LT	YA010 1502 TEE FXM BNO 12.12LG	STD
P506093-LT	YA010 1502 TEE MXMXF BNO 12.12"LG	STD
P506100-LT	YA010 1502 TEE MXMXM 12.12	STD
P506077-LT	YA015 1502 TEE FFXM BNO 12.12	STD
P505457-LT	YA015 1502 TEE FXMXF BNO 12.12	STD
P506088-LT	YA015 1502 TEE FXM BNO 12.12	STD

STD = Standard Product CF= Consult Factory

Weco® and Chiksan® low temperature ranges

Fittings

P/N	Description	STD/CF
P503531-LT	YA015 1502 CROSS FXF BNO 15.00"	CF
3269120-LT	YA015 1502 CROSS FXMXF BNO	CF
P506119-LT	YA015 1502 CROSS FXMXM BNO	CF
P506130-LT	YA015 1502 CROSS FXMXMF BNO	CF
P506171-LT	LA020 0602 00U ELB 90 MXM	STD
P506108-LT	YA020 0602 CROSS FXF BNO	CF
P506114-LT	YA020 0602 CROSS FXF BNO	CF
3262655-LT	YA020 0602 CROSS MXMXF BNO	CF
P506131-LT	YA020 0602 CROSS FXMXMF BNO	CF
3261768-LT	LA020 1502 00U ELB 90 MXM	STD
3257972-LT	YA020 1502 CROSS FXF BNO	CF
3257973-LT	YA020 1502 CROSS FXF BNO	CF
3258450-LT	YA020 1502 CROSS FXMXM BNO	CF
3258451-LT	YA020 1502 CROSS MXMXMF BNO	CF
3267282-LT	YA020 2002 CROSS FXF BNO	CF
P506115-LT	YA020 2002 CROSS FXMXMF BNO	CF
P506120-LT	YA020 2002 CROSS FXMXM BNO	CF
P506132-LT	YA020 2002 CROSS FXMXMF BNO	CF
P506174-LT	LA030 0602 00U ELB 90 DEG MXM	STD
P506109-LT	YA030 0602 CROSS FXF BNO 16.00"	CF
P506116-LT	YA030 0602 CROSS FXF BNO	CF
P506121-LT	YA030 0602 CROSS FXMXM BNO	CF
P506133-LT	YA030 0602 CROSS FXMXMF BNO	CF
P506110-LT	YA030 1502 CROSS FXF BNO	CF
P517401-LT	YA030 1502 CROSS MXF BNO 16.00	CF
P506122-LT	YA030 1502 CROSS FXMXM BNO	CF
P506134-LT	YA030 1502 CROSS FXMXMF BNO	CF
P506175-LT	LA030 1502 00U ELB 90 DEG MXM	STD
P506111-LT	YA040 0602 CROSS FXF BNO	CF
P504791-LT	YA040 0602 CROSS MXF BNO	CF
P506123-LT	YA040 0602 CROSS FXMXM BNO	CF
P506135-LT	YA040 0602 CROSS FXMXMF BNO	CF
P506177-LT	LA040 1002 00U ELB 90 DEG MXM	STD
P506112-LT	YA040 1002 CROSS FXF BNO	CF
P506117-LT	YA040 1002 CROSS FXMXF BNO	CF
P206124-LT	YA040 1002 CROSS FXMXM BNO	CF

STD = Standard Product CF= Consult Factory

P/N	Description	STD/CF
P506136-LT	YA040 1002 CROSS FXMXMF BNO	CF
P506137-LT	YA010 1502 CROSS FXMXM BNO	STD
P506146-LT	YA010 1502 CROSS MXMXM	STD
P506154-LT	YA010 1502 LAT MXF BNO 45DEG	STD
P506160-LT	YA010 1502 LAT FXF BNO 60DEG	STD
P506164-LT	YA010 1502 WYE MXF BNO 90DEG	STD
P506138-LT	YA015 1502 CROSS FXMXM BNO	CF
P506147-LT	YA015 1502 CROSS MXMXM	CF
P505434-LT	YA015 1502 LAT MXF BNO 45DEG	STD
P506166-LT	YA015 1502 WYE MXF BNO 90DEG	CF
P506139-LT	YA020 0602 CROSS FXMXM BNO	CF
P506148-LT	YA020 0602 CROSS MXMXM	CF
3263029-LT	YA020 0602 LAT MXF BNO 45DEG	STD
3262652-LT	YA020 0602 WYE MXF BNO 90DEG	CF
3257976-LT	YA020 1502 CROSS FXMXM BNO	CF
3257975-LT	YA020 1502 CROSS MXMXM	CF
3261420-LT	YA020 1502 LAT FXM BNO 45DEG	STD
3208846-LT	YA020 1502 WYE FXM BNO 90DEG	CF
P506140-LT	YA020 2002 CROSS FXMXM BNO	CF
P506149-LT	YA020 2002 CROSS MXMXM	CF
P506156-LT	YA020 2002 LAT MXF BNO 45DEG	CF
3254106-LT	YA020 2002 WYE MXF BNO 90DEG	CF
P506141-LT	YA030 0602 CROSS FXMXM BNO	CF
P506150-LT	YA030 0602 CROSS MXMXM	CF
P506142-LT	YA030 1502 CROSS MXMXF BNO	CF
P506151-LT	YA030 1502 CROSS MXMXM	CF
3266805-LT	YA030 1502 LAT MXF BNO 60DEG	STD
P506161-LT	YA030 1502 LAT FXF BNO 60DEG	STD
P506144-LT	YA040 0602 CROSS FXMXM BNO	CF
P506152-LT	YA040 0602 CROSS MXMXM	CF
P506158-LT	YA040 0602 LAT MXF BNO 19.50 60DEG	STD
P506145-LT	YA040 1002 CROSS FXMXM BNO	CF
P506153-LT	YA040 1002 CROSS MXMXM	CF
P519459-LT	YA040 1002 LAT MXF BNO 19.50 60DEG	STD
P518757-LT	YA040 1502 LAT MXF BNO 45 DEG	STD

Weco® and Chiksan® low temperature ranges

Pup joints

P/N	Description	STD/CF
3263200-LT	HA010 1502 024.00 INT MXF BNO	CF
P512501-LT	HA010 1502 036.00 INT MXF BNO	CF
3262915-LT	HA010 1502 048.00 INT MXF RET NUT BNO	CF
3261090-LT	HA010 1502 060.00 INT MXF RET NUT BNO	CF
3262229-LT	HA010 1502 072.00 INT 4140 BNO	CF
3266745-LT	HA010 1502 096.00 INT 4140 BNO	CF
3261496-LT	HA010 1502 120.00 INT 4140 BNO	CF
P516825-LT	HA020 1502 036.00 INT MXF RN BNO	STD
P516823-LT	HA020 1502 048.00 INT MXF RN BNO	STD
P516821-LT	HA020 1502 060.00 INT MXF RN BNO	STD
P516820-LT	HA020 1502 072.00 INT MXF RN BNO	STD
P516810-LT	HA020 1502 096.00 INT MXF RN BNO	STD
P516485-LT	HA020 1502 120.00 INT MXF RET NUT BNO	STD
P516817-LT	HA020 1502 144.00 INT MXF RN BNO	STD
P517538-LT	HA030 1502 036.00 INT MXF RET NUT BNO	STD
P517582-LT	HA030 1502 048.00 INT MXF RET NUT BNO	STD
P517664-LT	HA030 1502 060.00 INT MXF RN BNO	STD
P517672-LT	HA030 1502 072.00 INT MXF RN BNO	STD
P517674-LT	HA030 1502 096.00 INT MXF RN BNO	STD
P517111-LT	HA030 1502 120.00 INT MXF RET NUT BNO	STD
P525538-LT	HA030 2002 024.00 INT MXF RET NUT BNO	CF
P525539-LT	HA030 2002 036.00 INT MXF RET NUT BNO	CF
P525541-LT	HA030 2002 048.00 INT MXF RET NUT BNO	CF
P525543-LT	HA030 2002 060.00 INT MXF RET NUT BNO	CF
P519441-LT	HA030 2002 072.00 INT MXF RN BNO	CF
P525905-LT	HA030 2002 120.00 INT MXF RN BNO	CF
P520516-LT	HA040 1502 048.00 INT MXF RN BNO	CF
P518458-LT	HA040 1502 060.00 INT MXF RN BNO	CF
P518450-LT	HA040 1502 096.00 INT MXF RN BNO	CF
P518437-LT	HA040 1502 120.00 INT MXF RN BNO	CF
P508589-LT	HA020 1502 024.00 NPST MXF RET NUT BNO	STD
P508590-LT	HA020 1502 036.00 NPST MXF RET NUT BNO	STD
P508591-LT	HA020 1502 048.00 NPST MXF RET NUT BNO	STD
P508592-LT	HA020 1502 060.00 NPST MXF RET NUT BNO	STD
P508593-LT	HA020 1502 072.00 NPST MXF RET NUT BNO	STD
P508600-LT	HA030 1502 024.00 NPST MXF RET NUT BNO	STD
P508601-LT	HA030 1502 036.00 NPST MXF RET NUT BNO	STD
P508602-LT	HA030 1502 048.00 NPST MXF RET NUT BNO	STD
P508603-LT	HA030 1502 060.00 NPST MXF RET NUT BNO	STD
P508604-LT	HA030 1502 072.00 NPST MXF RET NUT BNO	STD
P510406-LT	HA040 0602 048.00 NPST MXF RET NUT BNO	CF
P510407-LT	HA040 0602 060.00 NPST MXF RET NUT BNO	CF
P510408-LT	HA040 0602 072.00 NPST MXF RET NUT BNO	CF
P512866-LT	HA040 1002 024.00 NPST MXF RET NUT BNO	CF
P512867-LT	HA040 1002 036.00 NPST MXF RET NUT BNO	CF
P510400-LT	HA040 1002 048.00 NPST MXF RET NUT BNO	CF
P510401-LT	HA040 1002 060.00 NPST MXF RET NUT BNO	CF
P510402-LT	HA040 1002 072.00 NPST MXF RET NUT BNO	CF
P520514-LT	HA040 1502 024.00 NPST MXF RET NUT BNO	CF
P520515-LT	HA040 1502 036.00 NPST MXF RET NUT BNO	CF
P520520-LT	HA040 1502 048.00 NPST MXF RET NUT BNO	CF

STD = Standard Product CF= Consult Factory

Weco® and Chiksan® low temperature ranges

Pup joints

P/N	Description	STD/CF
6101173-LT	HA040 0602 060.00 NPST 4130	CF
3251807-LT	HA040 0602 072.00 NPST 4130	CF
3265769-LT	HA040 1002 024.00 NPST MXF BNO	CF
P506629-LT	HA040 1002 036.00 NPST MXF BNO	CF
3265771-LT	HA040 1002 048.00 NPST MXF BNO	CF
3265772-LT	HA040 1002 060.00 NPST MXF BNO	CF
3265773-LT	HA040 1002 072.00 NPST MXF BNO	CF
3256612-LT	HA010 1502 096.00 NPST MXF BNO	CF
3265583-LT	HA010 1502 120.00 NPST MXF BNO	CF
P504985-LT	HA010 1502 144.00 NPST MXF BNO	CF
3254969-LT	HA015 1502 096.00 NPST MXF BNO	CF
3256062-LT	HA015 1502 120.00 NPST MXF BNO	CF
P528319-LT	HA020 0602 120.00 NPST MXF BNO	CF
3265739-LT	HA020 0602 144.00 NPST MXF BNO	CF
3255326-LT	HA020 1502 096.00 NPST MXF BNO	STD
3255325-LT	HA020 1502 120.00 NPST MXF BNO	STD
3255324-LT	HA020 1502 144.00 NPST MXF BNO	STD
3265728-LT	HA020 1502 240.00 NPST MXF BNO	STD
P504506-LT	HA030 0602 096.00 NPST MXF BNO	CF
3267338-LT	HA030 0602 120.00 NPST MXF BNO	CF
P501344-LT	HA030 0602 144.00 NPST MXF BNO	CF
3255320-LT	HA030 1502 096.00 NPST MXF BNO	STD

STD = Standard Product CF= Consult Factory

P/N	Description	STD/CF
3255423-LT	HA030 1502 120.00 NPST MXF BNO	STD
3255381-LT	HA030 1502 144.00 NPST MXF BNO	STD
3255427-LT	HA030 1502 240.00 NPST MXF BNO	STD
P514350-LT	HA040 0602 096.00 NPST 4130	CF
3251808-LT	HA040 0602 120.00 NPST 4130	CF
3265775-LT	HA040 1002 096.00 NPST MXF BNO	CF
3265777-LT	HA040 1002 120.00 NPST MXF BNO	CF
P513374-LT	HA020 1502 036.00 NPST MXF DN BNO	STD
3265908-LT	HA020 1502 048.00 NPST MXF DN BNO	STD
3265909-LT	HA020 1502 060.00 NPST MXF DN BNO	STD
P511842-LT	HA020 1502 072.00 NPST MXF DN BNO	STD
P512102-LT	HA020 1502 096.00 NPST MXF DN BNO	STD
3265906-LT	HA020 1502 120.00 NPST MXF DN BNO	STD
3267024-LT	HA030 1502 024.00 NPST MXF DN BNO	STD
3267025-LT	HA030 1502 048.00 NPST MXF DN BNO	STD
3267026-LT	HA030 1502 060.00 NPST MXF DN BNO	STD
P513301-LT	HA030 1502 072.00 NPST MXF DN BNO	STD
3267053-LT	HA030 1502 120.00 NPST MXF DN BNO	STD
P514712-LT	HA040 0602 060.00 NPST 4130 W/DET NUT	CF
P514711-LT	HA040 0602 072.00 NPST 4130 W/DET NUT	CF
P514713-LT	HA040 0602 096.00 NPST 4130 W/DET NUT	CF
P514715-LT	HA040 0602 120.00 NPST MXF W/DET NUT BNO	CF

Coflexip® flexible pipe

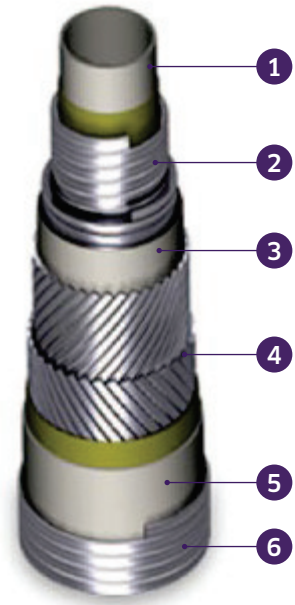

1. The thermoplastic inner tube makes the pipe leak-tight.
2. The carcass, with interlocked zeta and flat steel spiral pressure, resists internal pressure and external crunching loads.
3. The intermediate thermoplastic sheath is an anti-friction layer.
4. The double crosswound steel armors resist axial loads and protect the pipe from torsional strain resulting from handling and working conditions.
5. The thermoplastic outer jacket protects the armors from external corrosion.
6. The stainless steel outer wrap (SSOW) protects the pipe from mechanical impact, abrasion, weathering, and accidental mishandling.

Features

- ▶ Structural stability due to the distinct functions of each component layer.
- ▶ High crush resistance
- ▶ Integral end-fittings
- ▶ Supplied with any standard connector
- ▶ No maintenance (no intermediate seals to be replaced)
- ▶ Nikaflex treated end-fittings mean no corrosion
- ▶ Smaller OD and lower weight compared with conventional hoses of same ID and working pressure
- ▶ Available in any length
- ▶ Proven reliability: the industry's confidence in TechnipFMC quality is confirmed on hundreds of rigs worldwide
- ▶ All drilling and service application lines are pressure tested at full test pressure for a minimum of 24 hours before leaving our plant
- ▶ Allows for easier and more timely rigging up and rigging down of equipment
- ▶ Hydrogen sulfide (H₂S) and carbon dioxide (CO₂) limits:

Pressure Rating - PSI	Temperature - F (C)	Rating
10,000 (690)	236 (110)	CO ₂ + H ₂ S < 50%
10,000 (690)	266 (130)	CO ₂ + H ₂ S < 30%
15,000 (1,034)	266 (130)	CO ₂ + H ₂ S < 10%

- ▶ Compatible with a number of fluids. Refer to OEM guidelines for additional information.

Applications

- ▶ Exploration and appraisal well testing
- ▶ Cleanup and flowback
- ▶ Production and in-line testing (including multiphase flow metering)
- ▶ Extended well testing
- ▶ Early production facilities

Equipment specifications

Nominal ID size	Part No.	Working pressure psi (bar)	Design temperature °F (°C)	Dimensions		Liner type	Weight In (kg)	Connections
				Length ft (m)	OD in (cm)			
2 in. (50.8 mm)	102079794	15,000 (1034)	-4 to 266 (-20 to 130)	25 (7.6)	4.9 (12.4)	Coflon®	737.5 (334.5)	2-1/16-in., 15,000-psi API 6A Type 6BX flanges
	102107829	15,000 (1034)	-4 to 266 (-20 to 130)	30 (9.1)	4.9 (12.4)	Coflon®	885 (401.4)	2-1/16 in., 15,000 psi API 6A Type 6BX flanges
	102284390	15,000 (1034)	-4 to 266 (-20 to 130)	55 (16.8)	4.9 (12.4)	Coflon®	3404 (1544)	2-in., Fig. 2202 MALE (W) x FEMALE (T)
	102058509	15,000 (1034)	-4 to 266 (-20 to 130)	55 (16.8)	4.9 (12.4)	Coflon®	1925 (873)	2-1/16 in., 15,000 psi API 6A Type 6BX flanges
	102136919	15,000 (1034)	-4 to 266 (-20 to 130)	85 (25.9 m)	4.9 (12.4)	Coflon®	2900 (1315)	2-1/16-in., 15,000-psi API 6A Type 6BX flanges
3 in. (76.2 mm)	101754846	15,000 (1034)	-4 to 266 (-20 to 130)	55 (16.8)	6.5 (16.5)	Coflon®	3404 (1544)	3-1/16-in., API 6A hubs (BX-154)
	102284391	15,000 (1034)	-4 to 266 (-20 to 130)	55 (16.8)	6.5 (16.5)	Coflon®	3200 (1451)	3-in., Grayloc® D27 connections
	102107821	15,000 (1034)	-4 to 266 (-20 to 130)	60 (18.3)	6.5 (16.5)	Coflon®	3468 (1573)	3-1/16-in., API 6A hubs (BX-154)
	102107820	15,000 (1034)	-4 to 266 (-20 to 130)	65 (19.8)	6.5 (16.5)	Coflon®	3732 (1693)	3-1/16-in., API 6A hubs (BX-154)
	102107819	15,000 (1034)	-4 to 266 (-20 to 130)	70 (21.3)	6.5 (16.5)	Coflon®	3404 (1544)	3-1/16-in., API 6A hubs (BX-154)
	102130108	15,000 (1034)	-4 to 266 (-20 to 130)	85 (25.9)	6.5 (16.5)	Coflon®	4133 (2279)	3-1/16-in., API 6A hubs (BX-154)
4 in. (101.6 mm)	102144706	10,000 (690)	-4 to 266 (-20 to 130)	60 (18.3)	7.2 (18.3)	Coflon®	3730 (1692)	4-1/16-in., API 6A flange (BX-155)
	102272862	10,000 (690)	-4 to 266 (-20 to 130)	60 (18.3)	7.2 (18.3)	Coflon®	3730 (1692)	4-1/16-in., API 6A hubs (BX-155)

Notes:

Equipment is designed to API - 16C, NACE MR0175, and NORSOK standards, as applicable and documented on individual datasheets. These ratings are guidelines only. Contact your TechnipFMC representative for further information.

Manifold trailers and skids

Ten or twelve station Articulating Frac Arm Manifold (AFAM) trailer



Features

- ▶ High pressure system is separated from the chassis through isolators, providing vibration resistance and reducing fatigue on high pressure lines.
- ▶ Meets DOT rules and regulations.
- ▶ Dual hydraulic power unit ensures functioning arms.
- ▶ Patented Chiksan® Longsweep™ TripleStep™ Swivel Joints used in each arm providing longer life.
- ▶ Rated for pressures up to 15,000 psi standard service and flow up to 107 BPM
- ▶ Reduces weight of pump truck by carrying iron on AFAM.
- ▶ Has all of the necessary degrees of freedom to allow for correct connection to the pump truck anywhere in a 12 foot radius every time.
- ▶ Self balancing arm requires less lifting by only one man.
- ▶ Isolation valves at each station allow flow to be re-routed allowing the job to continue in the event of an issue.
- ▶ High pressure lines are fully integral/No welded ends.
- ▶ Traditional manifold requires 20 man hours to hook up vs. AFAM requires only 1 man hour.

Ground level frac missile



Features

- ▶ 16-24 Pump Inlets
- ▶ Full Missile and transition flow iron (with check valves, plug valves and tees) mobilized
- ▶ Modular Pod Design 4 Pump Trucks/Pod
- ▶ 80% reduction in hammer union flowiron
- ▶ Single high pressure outlet line
- ▶ Dedicated low pressure fluid delivery
- ▶ 7" API 6A flanged connections
- ▶ 15,000 psi working pressure
- ▶ Capable of 120 BPM flow rate

Standard manifold trailer

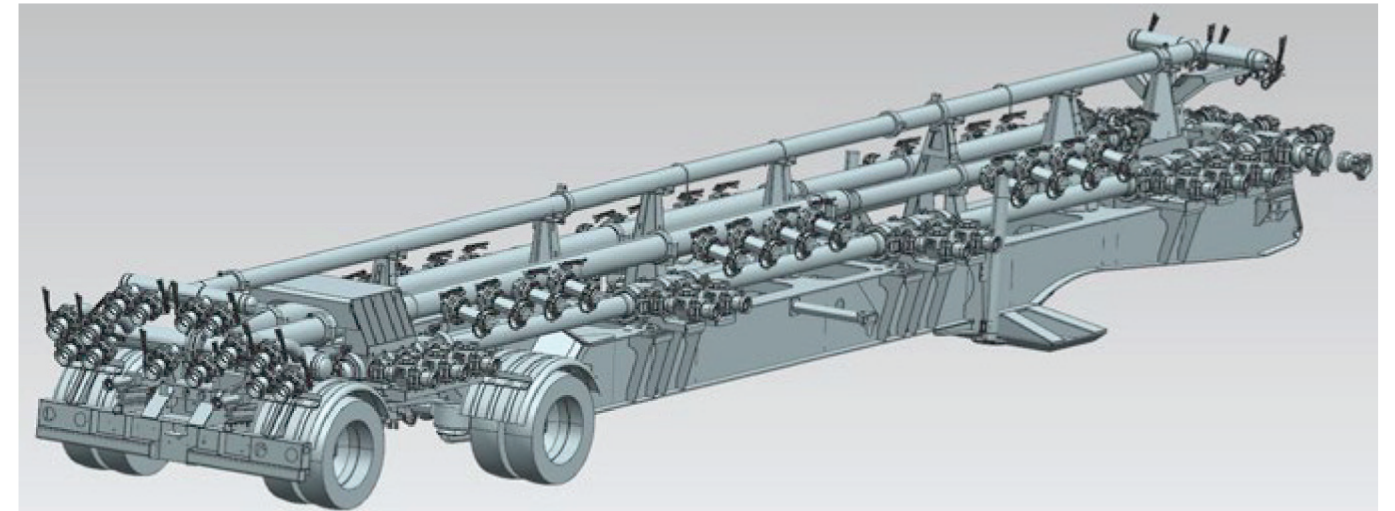

Features

- ▶ Fewer serialized HP iron components
- ▶ Eliminates erosion in center mainline/crossover section
- ▶ High pressure hub end connections utilize Grayloc clamps with TechnipFMC proprietary seals.
- ▶ Non-permit load trailer
- ▶ High pressure system is separated from the chassis through coiled cable suspension mounts, providing vibration resistance and reducing fatigue on high pressure lines.
- ▶ Meets DOT rules and regulations.
- ▶ Rated for pressures up to 15,000 psi standard service and flow up to 107 BPM.
- ▶ Plug Valves or Check Valves isolate each station from pumping unit.
- ▶ High pressure lines are fully integral. No welded ends.
- ▶ Butterfly Valves between the left and right side of the low pressure

Inspection services

Chiksan® and Weco® flowline products have set global industry standards for quality, reliability, and service life for almost 75 years. However, superior products alone are not enough to meet the diverse challenges that operators and well-servicing companies face today. TechnipFMC pledges to meet or exceed customer expectations by providing value through services, technology, and competencies, and by safely following established standards without compromise. This total solutions approach to managing flowline equipment is helping flowline customers worldwide realize the maximum value and service life from their fluid control assets.

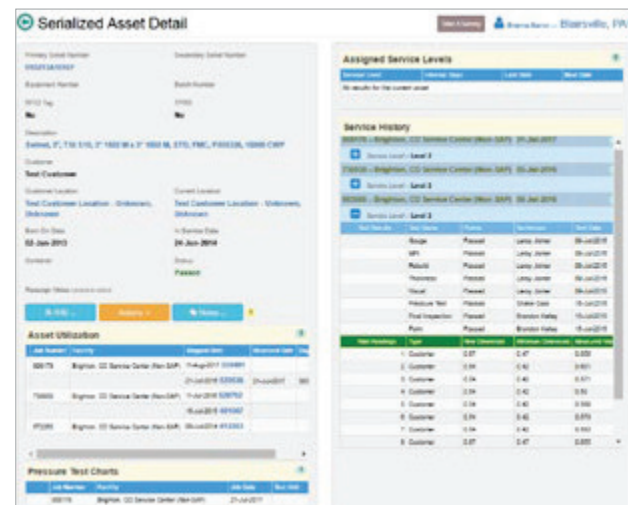
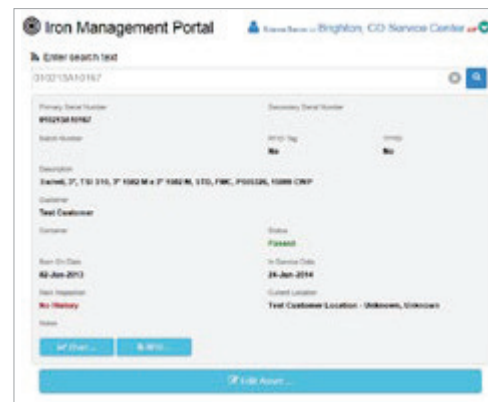

Asset management

Tracking and maintaining the volume of flowline equipment used in flowline services is a major undertaking. Asset management is a cooperative program where specially trained TechnipFMC personnel inventory, track, and maintain a customer's flowline assets at their facility or in a designated TechnipFMC facility. Asset management is helping customers world-wide significantly increase equipment utilization rates and service life while reducing total costs and safety concerns.

Mobile inspection and repair

TechnipFMC introduced its mobile inspection and repair service in 1996. Today, the industry's largest fleet of mobile units performs complete inspection and repair services at customer locations throughout the world. The mobile package includes inspection, testing, repair, documentation, and certification with the goal of extending product life and reducing operator costs.

Service centers

To keep Chiksan and Weco products in top working condition, TechnipFMC offers factory rebuild services from strategic locations worldwide. TechnipFMC is aggressively working to expand its in-house refurbishment services to meet growing demand, including butterfly valve and cement head inspection and repair.

Spare parts management

Chiksan and Weco® products are manufactured to precise dimensional tolerances using specialized materials of construction, unique machining processes, and strict quality control measures. The service life of these products can be extended with routine maintenance and periodic repair using genuine TechnipFMC spare parts.

InteServ

TechnipFMC's propriety database, InteServ, is a web-based global asset tracking database that tracks customer property, asset lifecycles, and inspection history for customer owned property as well as internal TechnipFMC property. InteServ offers a desktop version, a mobile application, a disconnected version, and customer branded sites. InteServ is also integrated with other applications, such as ultrasonic thickness testing software, automated pressure testing software, and RFID. Moreover, through the use of application programming Interfaces and webservices, InteServ is able to communicate with other databases successfully. The combination of these applications offers high-value solutions to customers through traceability and data-analysis. Lastly, through continuing development, InteServ is constantly adapting to meet customer evolving needs.

Desktop platform

The desktop version of InteServ is completely customer facing, with active customer accounts through daily logins. All users, including customers have the ability to search and pull reports for self-service data analysis. Additional features include:

- ▶ RFID compatibility
- ▶ APT (Automated Pressure Testing Software) Compatibility
- ▶ Ultrasonic thickness testing software compatibility
- ▶ Branded sites
- ▶ Sales order compatibility
- ▶ Offline / Disconnected functionality

Mobile platform

Mobile InteServ is a revolutionary, cutting-edge mobile application that tracks: customer asset receiving, inspection, throughput, output, and real-time shipping. With an easy and beautiful user-friendly UI (User Interface), InteServ can move freely through a shop, base, or facility for the most accurate tracking throughout the inspection process. Mobile InteServ is RFID capable and can be accessed on tablets and even smart phones. Additional features include:

- ▶ RFID compatibility
- ▶ APT (Automated Pressure Testing Software) Compatibility
- ▶ Time tracking on inspection tests
- ▶ Elimination of paper through digital processes
- ▶ Sales order and service order compatibility
- ▶ Seamless user experience with a focus on limiting the number of required clicks
- ▶ Documentation upload

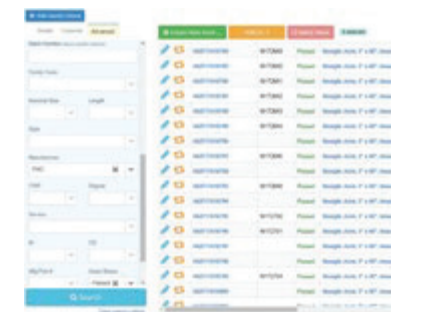

Warnings and cautions

TechnipFMC cannot anticipate all of the situations a user may encounter while installing and using TechnipFMC products. Therefore, the user of TechnipFMC products MUST know and follow all applicable industry specifications and practices on the safe installation and use of these products. For additional safety information, refer to TechnipFMC product catalogs, product brochures, and installation, operating, and maintenance manuals, which can be accessed at www.technipfmc.com, or contact TechnipFMC at **800-772-8582**.

Failure to follow these warnings may result in death, serious personal injury, and/or severe property damage.

- ▶ Never mix or assemble components, parts, or end connections with different pressure ratings. Mismatched components may fail under pressure.
- ▶ Never use or substitute non-TechnipFMC components or parts in TechnipFMC products or assemblies.
- ▶ Never modify or repair TechnipFMC products in a manner not specifically directed in instructions published by TechnipFMC.
- ▶ Never strike, tighten, loosen, or attempt repairs on pressurized components or connections.
- ▶ Never exceed the rated working pressure of the product.
- ▶ Complete and proper make-up of components and connections is required to attain rated working pressure. Always use care when handling, inspect, and be attentive to threaded components before, during and after make-up.
- ▶ Never use severely worn, eroded, or corroded products. Contact TechnipFMC for more information on how to identify the limits of erosion and corrosion.
- ▶ Never strike wing union nuts having severely flattened and extruded ears. This condition can result in flying debris leading to serious personal injury and must immediately be addressed by either grinding off extruded material or removing the nut from service.
- ▶ Always follow safe practices when using products in overhead applications. Products not properly secured may fall.
 - Never exceed the load rating of lifting devices on products or lifting equipment.
 - Use of TechnipFMC products in suspension applications can result in over-stress conditions leading to catastrophic failure.
 - If externally applied loads are anticipated, consult factory.
- ▶ Always follow safe practices when manually lifting and carrying products.
- ▶ Always select only appropriate product and materials for the intended service:
 - Never expose standard service products to sour gas fluids (Refer to NACE MR-01-75). Do not interchange sour gas with standard service components.
 - Always use appropriate safety precautions when working with ferrous products in below freezing temperatures. Freezing temperatures lower the impact strength.
- ▶ Always follow manufacturer's instructions and Material Safety Data Sheet direction when using solvents.
- ▶ Always make certain that personnel and facilities are protected from residual hazardous fluids before disassembly of any product.
- ▶ Whenever leakage is detected, remove part from service.
- ▶ Do not subject TechnipFMC products to excessive external loads. These include axial loads, bending and torsional loads. The product's design rating is only valid in the absence of external loading. Improper external loading may severely limit the performance of the product and create an unsafe condition.

The applications of TechnipFMC products are in working environments and systems which must be properly designed and controlled. Safety procedures and policies MUST be clearly established by the user and followed. Always use appropriate protective equipment.

Contact us

Canada

7035- 68 Ave
Edmonton, Alberta T6B 3E3
Tel.: + 1 800 772 8582

United States

2825 W. Washington St.
Stephenville, Texas, 76401
Tel.: + 1 800 772 8582

3844 South Loop 1604 E.
San Antonio, Texas, 78264
Tel.: + 1 800 772 8582

8950 East Interstate 20,
Odessa, Texas, 79765
Tel.: + 1 800 772 8582

1575 County Road 2
Brighton, Colorado, 80603
Tel.: + 1 800 772 8582

11740 Katy Freeway
Houston, Texas, 77079
Tel.: + 1 800 772 8582

Mexico

Calle Laurel Lote 41 Manzana 19
Colonia Bruno Pagliai
Veracruz, Veracruz, Mexico CP
91697
Tel.: +52 229 923 1470

Brazil

Rod. Amaral Peixoto, Km 187
Macaé, Rio de Janeiro, Brazil
27970-020
Tel.: +55 22 2773 0377

Rod. Presidente Dutra,
2660 - Pavuna
Rio de Janeiro, RJ, Brazil
21535-900
Tel.: +55 22 2773 0377

Argentina

Lola Mora 421 - oficina 1802
Ciudad Autónoma de Buenos Aires,
Argentina - Código postal C1107BA
Tel.: +54 11 6009 1140

Singapore

149 Gul Circle
Singapore, 629605
Tel.: +65 68613011

Russia

5 Bazovaya St.,
628422 Surgut,
Khanty-Mansiysk Autonomous
District,
Russian Federation
Sales Tel.: +7 915 115 71 88
Main: +7 3462 77 44 37

United Arab Emirates

B41 Oilfield Supply Centre
Jebel Ali Free Zone
PO Box 3228
Dubai, United Arab Emirates
Tel.: +971 4 883 0303

Netherlands

Industrieweg 31
7761 PV Schoonebeek
The Netherlands
Tel.: +31 524 531 111

Colombia

Calle 38 # 8 - 62 Piso 6
Edificio Tipiel
Bogota - Colombia ZC 110311
Persona De Contacto:
Diana Paola Coy
Tel.: +57 1 546 2525

United States

One Subsea Lane
Houston, Texas 77044 USA
Tel.: +1 281 591 4000

London

One St Paul's Churchyard
London, U.K. EC4M 8AP
Tel.: +44 (0)20 3429 3950

France

89 avenue de la Grande Armée
75116 - Paris - France
Tel.: +33 (0)1 47 78 24 00

TechnipFMC.com

© TechnipFMC plc 2018

SP015